

# Switch with Z-Wave Technology

decora smart™



kits, and wallplates. The switches feature true rocker action, pressing the top to turn on and the bottom to turn off. To meet any decor, color change kits are available in white, ivory, light almond, gray, black, and brown. For the most professional and cleanest installation, pair the device with an optional Leviton screwless wallplate.

## Z-WAVE PLUS CERTIFICATION

- Increased communication range
- Network Wide Inclusion
- Support for beaming and secure commands
- Over The Air (OTA) updates

## FEATURES AND BENEFITS

- Rated for CFL and LED loads up to 600W
- Rated for incandescent loads up to 1800W
- Compatible with Leviton vizia rf + systems
- Multi-location (3-way) dimming is achieved using DD0SR-1 Coordinating Remote (no LED indicator) or DD0SR-DL Matching Remote (with LED indicator).
- Frequency: 908.42 MHz

## AGENCY STANDARDS AND COMPLIANCE

- Complies with UL 917
- CSA Certified (File #003413)
- NOM-ANCE Certified
- Complies with FCC Part 15, Class B
- Z-Wave Plus Certified

## RATINGS

- Incandescent - 1800W - 120VAC, 60Hz
- LED/CFL - 5A, 600W - 120VAC, 60Hz
- Fluorescent - 15A - 120VAC, 60Hz;  
8A - 277VAC, 60Hz
- Resistive - 15A - 120VAC, 60Hz
- Motor - 1/2 HP - 120VAC, 60Hz

## WARRANTY INFORMATION

Five-Year Limited Warranty

## APPLICATION

The Z-Wave Plus Switch uses the latest generation of Leviton's lighting control technology. It supports LED and CFL technologies up to 600 Watts along with support for legacy incandescent lighting loads up to 1800 Watts, along with support for Fluorescent, Resistive, and Motor loads. The DZ15S is Z-Wave Plus certified, ensuring the latest technology, increased communication range, network wide inclusion, and over the air updates. The new lighting control accessories are engineered to function with extremely sensitive, low-wattage light sources, such as a single LED bulb in a hallway or a strand of holiday lights, ensuring LEDs do not glow when off. The highly advanced design features two-way feedback, is scene capable, and is supported by security systems, hubs, and gateways.

## AESTHETICS

Switches leverage Leviton's popular rocker paddle, along with compatible accessories including three-way devices, color change

## Leviton Manufacturing Co., Inc. Global Headquarters

201 N. Service Rd. Melville, NY 11747-3138 Tech Line: 1-800-824-3005 Fax: 1-800-832-9538

## Leviton Manufacturing Co., Inc. Energy Management, Controls and Automation

865 Fulton St., Suite 500, New Orleans, LA, 70130. Tel: 504-608-9001

Visit our Website at: [www.leviton.com/decorasmart](http://www.leviton.com/decorasmart)

©2019 Leviton Manufacturing Co., Inc. All rights reserved. Subject to change without notice.

Switch with Z-Wave Technology

**SINGLE POLE WIRING DIAGRAM**

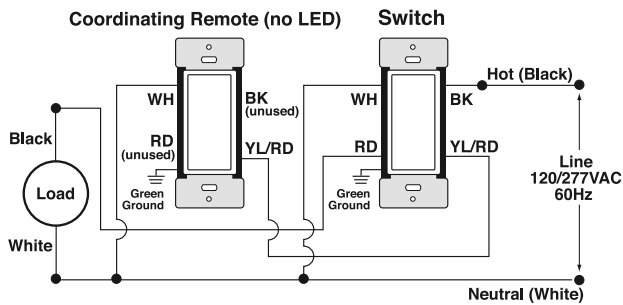

**THREE-WAY WIRING DIAGRAM**

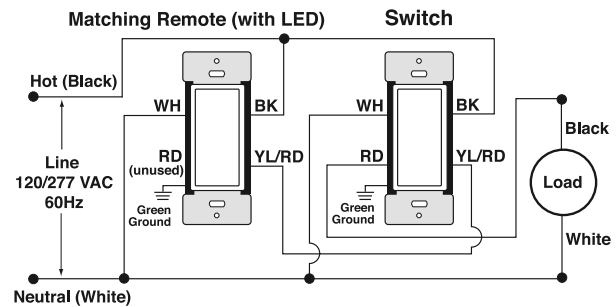

**ORDERING INFORMATION**

DESCRIPTION	CAT. NO.
15A Switch with Z-Wave Technology	DZ15S-1
Coordinating Switch Remote	DD0SR-1
Matching Switch Remote	DD0SR-DL
Switch Color Change Kit, Black	DDKIT-0SE
Switch Color Change Kit, Gray	DDKIT-0SG
Switch Color Change Kit, Brown	DDKIT-0SB
Switch Color Change Kit, Ivory	DDKIT-0SI
Replacement Switch Color, White	DDKIT-0SW
Replacement Switch Color, Light Almond	DDKIT-0ST

**Leviton Manufacturing Co., Inc. Global Headquarters**

201 N. Service Rd. Melville, NY 11747-3138 Tech Line: 1-800-824-3005 Fax: 1-800-832-9538

**Leviton Manufacturing Co., Inc. Energy Management, Controls and Automation**

865 Fulton St., Suite 500, New Orleans, LA, 70130. Tel: 504-608-9001

Visit our Website at: [www.leviton.com/decorasmart](http://www.leviton.com/decorasmart)

©2019 Leviton Manufacturing Co., Inc. All rights reserved. Subject to change without notice.

SAT-10110  
REV OCT 2019