



# Installing and Testing the Smart GFCI Outlet

Please read this leaflet completely before getting started.

**NOTE:** After the GFCI has been installed, please refer to the Getting Started Guide for setup with the My Leviton™ app. Visit <https://goto.leviton.com/SmartGFCI>

Avoid miswiring the GFCI. See video link for help on wiring.



DI-000-D2GFX-02B-W

## CAUTION

- To prevent severe shock or electrocution always turn the power OFF at the service panel before working with wiring.
- Use this GFCI with copper or copper-clad wire. Do not use it with aluminum wire.
- Do not install this GFCI receptacle on a circuit that powers life support equipment because if the GFCI trips it will shut down the equipment.
- For installation in damp or wet locations, the GFCI receptacle must be listed and marked as Weather Resistant (WR).
- For installation in wet locations, protect the GFCI receptacle with a weatherproof cover that will keep both the receptacle and any plugs dry
  - This GFCI receptacle is not Weather Resistant (WR) and should not be installed in damp or wet locations.
- If there is a GFCI circuit breaker on the circuit and the Smart GFCI Outlet trips, the Smart GFCI Outlet may not be able to send alerts due to loss of power on the circuit if the GFCI circuit breaker also trips.
- Must be installed in accordance with national and local electric codes.

## 1. What is a GFCI?

A GFCI receptacle is different from conventional receptacles. In the event of a ground fault, a GFCI will trip and quickly stop the flow of electricity to prevent serious injury.

### Definition of a ground fault:

Instead of following its normal safe path, electricity passes through a person's body to reach the ground. For example, a defective appliance can cause a ground fault.

A GFCI receptacle does **NOT** protect against circuit overloads, short circuits, or shocks. For example, you can still be shocked if you touch bare wires while standing on a non-conducting surface, such as a wood floor.

### NOTE:

GFCIs contain a lockout feature that will prevent RESET if:

- There is no power being supplied to the GFCI.
- The GFCI is miswired due to reversal of the LINE and LOAD leads.
- The GFCI cannot pass its internal test, indicating that it may not be able to provide protection in the event of a ground fault.

## 2. The GFCI's features

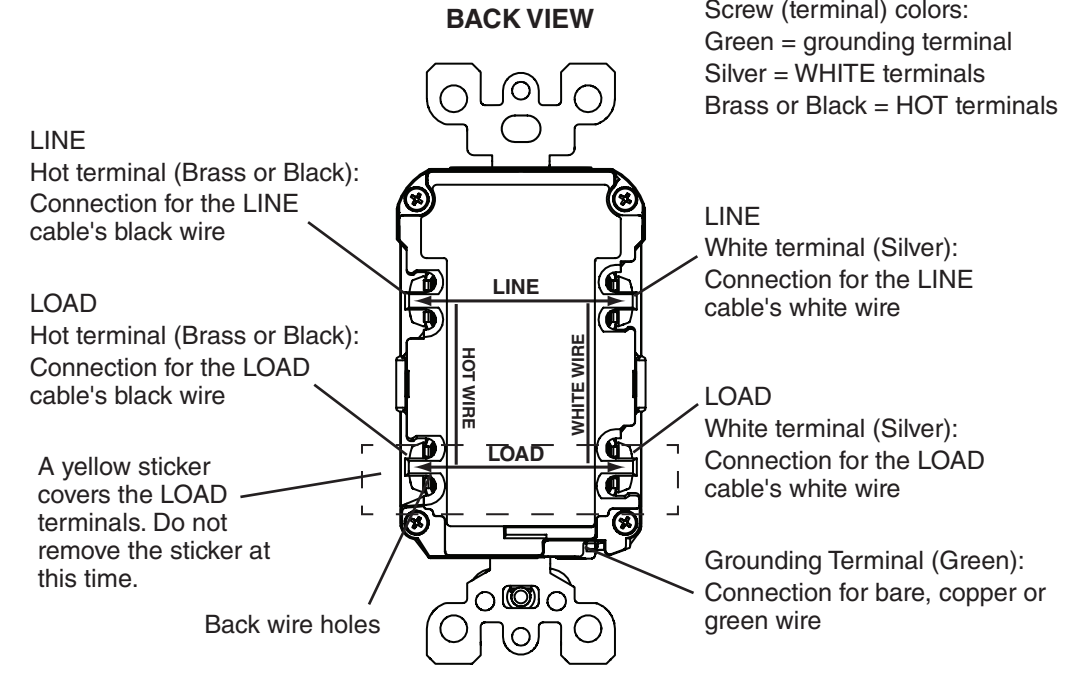
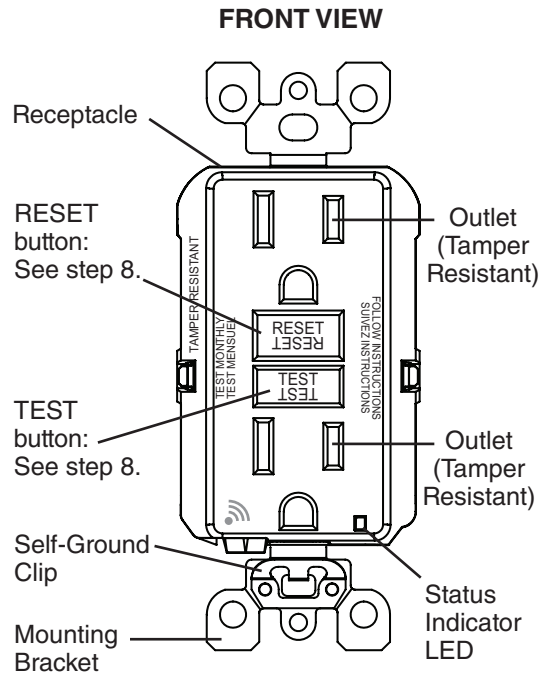

Screw (terminal) colors:  
Green = grounding terminal  
Silver = WHITE terminals  
Brass or Black = HOT terminals

## 3. Should you install it?

Installing a GFCI receptacle can be more complicated than installing a conventional receptacle.

Make sure that you:

- Understand basic wiring principles and techniques.
- Can interpret wiring diagrams.
- Have circuit wiring experience.
- Are prepared to take a few minutes to test your work, making sure that you have wired the GFCI receptacle correctly.

## 4. LINE vs. LOAD

A cable consists of 2 or 3 wires.

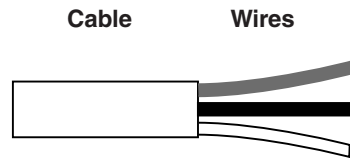

### LINE cable:

Delivers power from the service panel (breaker panel or fuse box) to the GFCI. If there is only one cable entering the electrical box, it is the LINE cable. This cable should be connected to the GFCI's LINE terminals only.

### LOAD cable:

Delivers power from the GFCI to another receptacle in the circuit. This cable should be connected to the GFCI's LOAD terminals only. The LOAD terminals are under the yellow sticker. Do **NOT** remove the sticker at this time.

## 5. Turn the power OFF

Plug an electrical device, such as a lamp or radio, into the receptacle on which you are working. Turn the lamp or radio ON. Then, go to the service panel. Find the breaker or fuse that protects that receptacle. Place the breaker in the OFF position or completely remove the fuse. The lamp or radio must turn OFF.

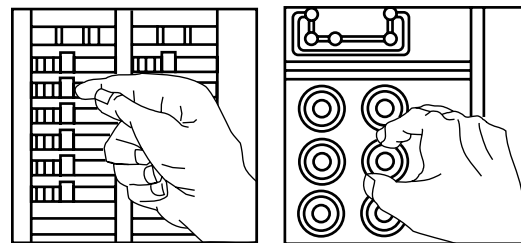

Next, plug in and turn ON the lamp or radio at the receptacle's other outlet to make sure the power is OFF at both outlets. If the power is not OFF, stop work and call an electrician to complete the installation.

## 6. Identify cables/wires

### Important:

DO NOT install the GFCI receptacle in an electrical box containing (a) more than four (4) wires (not including the grounding wires) or (b) cables with more than two (2) wires (not including the grounding wire). Contact a qualified electrician if either (a) or (b) are true.

If you are replacing an old receptacle, pull it out of the electrical box without disconnecting the wires.

- If you see one cable (2-3 wires), it is the LINE cable. The receptacle is probably in position C (see diagram to the right). Remove the receptacle and go to step 7A.
- If you see two cables (4-6 wires), the receptacle is probably in position A or B (see diagram to the right). Follow steps a-e of the procedure to the right.

### Procedure: Box with two (2) cables (4-6 wires):

- Detach one cable's white wire and hot wires from the receptacle and cap each one separately with a wire connector. Make sure that they are from the same cable.
- Re-install the receptacle in the electrical box, attach the faceplate, then turn the power ON at the service panel.
- Determine if power is flowing to the receptacle. If so, the capped wires are the LOAD wires. If not, the capped wires are the LINE wires.
- Turn the power OFF at the service panel, label the LINE and LOAD wires, then remove the receptacle.
- Go to step 7B.

### Placement in circuit:

The GFCI's place in the circuit determines if it protects other receptacles in the circuit.

### Sample circuit:

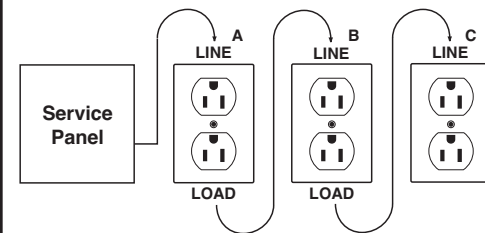

Placing the GFCI in position A will also provide protection to "load side" receptacles B and C. On the other hand, placing the GFCI in position C will not provide protection to receptacles A or B. Remember that receptacles A, B, and C can be in different rooms.

## 7. Connect the wires (choose A or B)... only after reading other side completely

**A: One Cable (2 or 3 wires) entering the box**

**OR**

**B: Two cables (4 or 6 wires) entering the box**

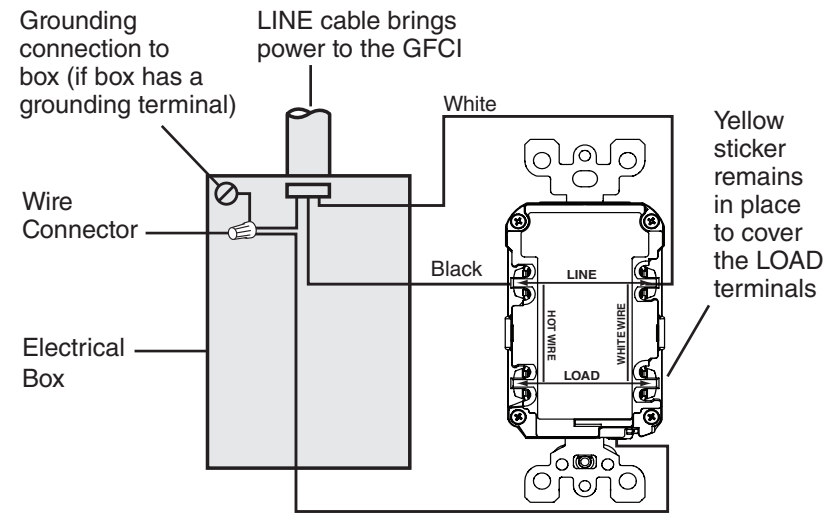

### About Wire Connections:

#### Side Wire:



**For Side wire -**  
Loop clockwise 2/3 of the way around screw. Tighten screws over wire loops to 14-18 in-lb.

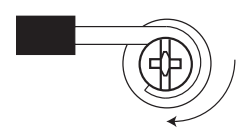

#### Back Wire:

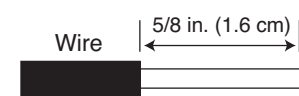

**For Back wire -**  
Insert bare wire fully and tighten terminal clamp on conductor ONLY. Tighten screws to 14-18 in-lb.

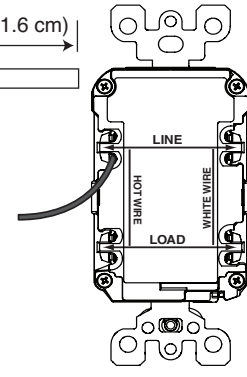

Torque values can also be found at [Leviton.com/torquevalue](http://Leviton.com/torquevalue).

### Connect the LINE cable wires to the LINE terminals:

- The white wire connects to the WHITE terminal (Silver)
- The black wire connects to the HOT terminal (Brass or Black)

### Connect the grounding wire (only if there is a grounding wire):

- For a box with no grounding terminal (diagram not shown): Connect the LINE cable's bare copper (or GREEN) wire directly to the grounding terminal on the GFCI receptacle.
  - For a box with a grounding terminal (diagram shown above): Connect a 6-inch bare copper (or GREEN) 12 or 14 AWG wire to the grounding terminal on the GFCI. Also connect a similar wire to the grounding terminal on the box. Connect the ends of these wires to the LINE cable's bare copper (or GREEN) wire using a wire connector.
- If these wires are already in place, check the connections.

### Complete the installation:

- Fold the wires into the box, keeping the grounding wire away from the WHITE and HOT terminals. Screw the receptacle to the box and attach the faceplate.
- Go to step 8.

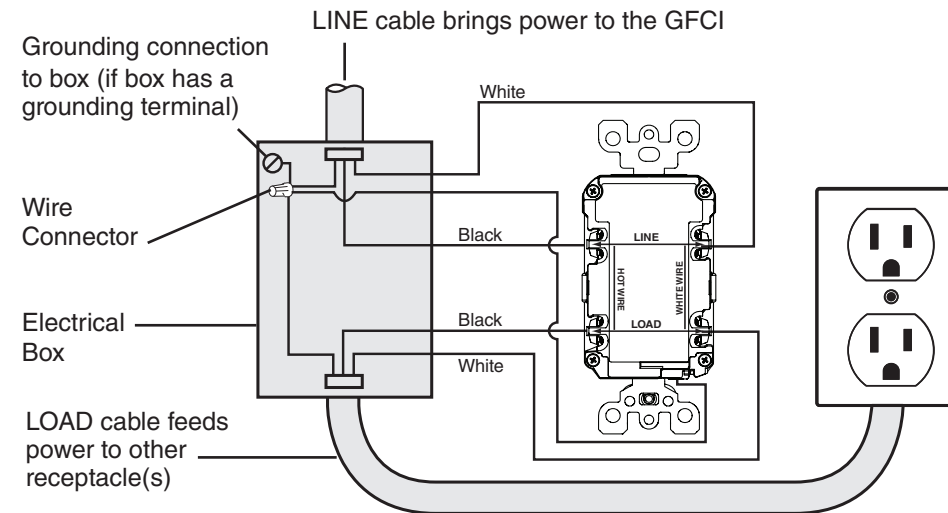

### About Wire Connections:

#### Side Wire:

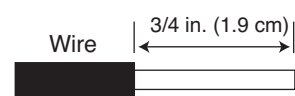

**For Side wire -**  
Loop clockwise 2/3 of the way around screw. Tighten screws over wire loops to 14-18 in-lb.

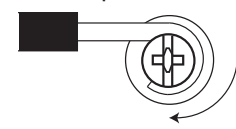

#### Back Wire:

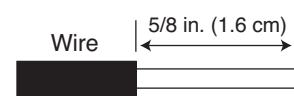

**For Back wire -**  
Insert bare wire fully and tighten terminal clamp on conductor ONLY. Tighten screws to 14-18 in-lb.

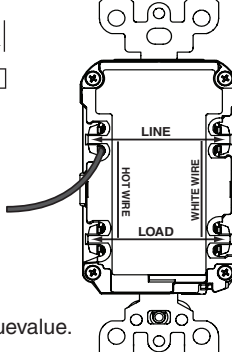

Torque values can also be found at [Leviton.com/torquevalue](http://Leviton.com/torquevalue).

### Connect the LINE cable wires to the LINE terminals:

- The white wire connects to the WHITE terminal (Silver)
- The black wire connects to the HOT terminal (Brass or Black)

### Connect the LOAD cable wires to the LOAD terminals:

- Remove the YELLOW sticker to reveal the LOAD terminals
- The white wire connects to the WHITE terminal (Silver)
- The black wire connects to the HOT terminal (Brass or Black)

### Connect the grounding wires (only if there is a grounding wire):

- Connect a 6-inch bare copper (or GREEN) 12 or 14 AWG wire to the grounding terminal on the GFCI. If the box has a grounding terminal, also connect a similar wire to the grounding terminal on the box. Connect the ends of these wires to the LINE or LOAD cable's bare copper (or GREEN) wire using a wire connector. If these wires are already in place, check the connections.

### Complete the installation:

- Fold the wires into the box, keeping the grounding wire away from the WHITE and HOT terminals. Screw the receptacle to the box and attach the faceplate.
- Go to step 8.

## 8. Test your work

### Why perform this test?

- If you miswired the GFCI it may not prevent personal injury or death due to a ground fault (electrical shock).
- If you mistakenly connect the LINE wires to the LOAD terminals, the GFCI will not reset and will not provide power to either the GFCI receptacle face or any receptacles fed from the GFCI.

## Procedure:

- This GFCI is shipped from the factory in the tripped condition and cannot be reset until it is wired correctly and power is supplied to the device. If you choose to relocate the GFCI, please return the outlet to this configuration by pressing the TEST button before you move it. Plug a lamp or radio into the GFCI (and leave it plugged in). Turn the power ON at the service panel. Ensure that the GFCI is still in the tripped condition by pressing the TEST button. The GFCI's LED indicator light should blink GREEN to indicate it is in the Setup mode, and the RESET button should be out.
- Press the RESET button fully. If the lamp or radio turns ON and the LED indicator light is ON and GREEN, the GFCI has been installed correctly. If the lamp or radio is OFF and the GFCI will not reset, go to the Troubleshooting section, as the Line and Load connections are reversed.
- If you installed your GFCI using step 7B, plug a lamp or radio into surrounding receptacles to see which one(s), in addition to the GFCI, lose power when you press the GFCI TEST button. Place a "GFCI PROTECTED OUTLET" sticker on every receptacle that lost power, then press the RESET button to reset the GFCI. DO NOT plug life-saving devices into any of the receptacles that lost power.
- Press the TEST button (then RESET button) every month to assure proper operation. If the GFCI cannot be reset, then it must be replaced.
- The Smart GFCI Outlet's Audible Alert for a trip notification is enabled by default. The Audible Alert can be disabled or enabled under the Device Settings in the My Leviton app. If the Smart GFCI has been tripped due to a fault and cannot be reset, you can silence the Audible Alert in the My Leviton app or press and hold the RESET button for 3 seconds. After silencing the Audible Alert, contact Leviton Customer Service or your local electrician.

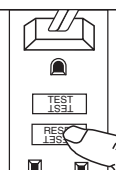
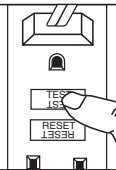
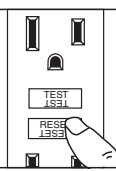

## TROUBLESHOOTING

Turn the power OFF and check the wire connections against the appropriate wiring diagram in step 7A or 7B. Make sure that there are no loose wires or loose connections. Also, it is possible that you reversed the LINE and LOAD connections. If the LED indicator light is not ON and the device is unable to reset, this could be a result of no power available. If you rewired any connections to the GFCI, you must start the test from the beginning as explained in the "Test your Work" section.

## SELF-TEST OPERATION

- A Self-Test GFCI receptacle has all the features of a conventional GFCI receptacle. In addition, this receptacle tests itself periodically to confirm the GFCI electronics are functional. The status indicator light will be solid GREEN when the GFCI is powered from Line side and working correctly.
- Self-Test Indications:** If the status indicator light is solid or flashing RED a problem may exist. Press the TEST button to trip the GFCI. If unable to reset, replace the GFCI. **NOTE:** The status indicator may flash RED at power "ON" and RESET.

Cat. No.	Description
D2GF1	15A, 125VAC, 60Hz, Wi-Fi Certified, Tamper Resistant, Smart GFCI Outlet
D2GF2	20A, 125VAC, 60Hz, Wi-Fi Certified, Tamper Resistant, Smart GFCI Outlet
All devices rated 20A feed-through	

## FOR CANADA ONLY

For warranty information and/or product returns, residents of Canada should contact Leviton in writing at **Leviton Manufacturing of Canada ULC** to the attention of the **Quality Assurance Department, 165 Hymus Blvd, Pointe-Claire (Quebec), Canada H9R 1E9** or by telephone at **1-800-405-5320**.

## PATENT STATEMENT

Patents covering this product, if any, can be found on [Leviton.com/patent](http://Leviton.com/patent)

## LIMITED 2 YEAR WARRANTY

For Leviton's limited 2 year product warranty, go to [www.leviton.com](http://www.leviton.com). For a printed copy of the warranty, call 1-800-824-3005.

**For Technical Assistance Call: 1-800-824-3005 (USA Only) or 1-800-405-5320 (Canada Only) [www.leviton.com](http://www.leviton.com)**