

# INSTALLATION INSTRUCTIONS

## Outdoor Meter Main, Ringless with Horn Bypass, OH/UG Service Entrance Enclosure



PK-A3412-10-00-0B

**IMPORTANT SAFETY INSTRUCTIONS - READ ALL INSTRUCTIONS BEFORE USING.**

### ⚠ WARNINGS

- **TO AVOID FIRE, SHOCK, OR DEATH, TURN OFF POWER SUPPLYING THIS EQUIPMENT AND CONFIRM POWER IS OFF,** before installing, removing, or servicing this equipment.
- This equipment **MUST BE** installed and serviced by an electrician.
- To be installed and/or used in accordance with electrical codes and regulations.
- Use **ONLY** approved fittings and clamps to avoid damage to wires.
- Leviton® circuit breakers **MUST BE** used with a Leviton circuit breaker enclosure.
- Before providing power to the load center, check all electrical connections and confirm that the wiring is correct.
- Replace all doors and covers before connecting power to this equipment.
- **SAVE THESE INSTRUCTIONS.**

### LIMITED PRODUCT WARRANTY

For Leviton's limited product warranty, go to [www.leviton.com](http://www.leviton.com). For a printed copy of the warranty, you may call 1-800-323-8920.

Patents covering this product, if any, can be found on [Leviton.com/patents](http://Leviton.com/patents).

## INSTALLATION

**WARNING: TO AVOID FIRE, SHOCK, OR DEATH, TURN OFF POWER SUPPLYING THIS EQUIPMENT AND CONFIRM POWER IS OFF,** before installing, removing, or servicing this equipment.

### Step 1: Removing meter and wiring compartment covers

- Slide **securing latch (A)** upward.
- Slide **meter cover (B)** down and out.
- Slide **wiring compartment cover (C)** down and out (*fig. 1*).

### Step 2: Bottom feed applications (Optional)

**NOTE:** Install the closing plate (included) to the overhead opening of the enclosure for bottom feed applications.

**NOTE:** For bottom feed applications, wires and conductors should be run through the wire trough on the left side. For top feed applications, the wire trough can be removed, if desired, by removing the top securing screw and sliding upward and out.

**NOTE:** Before removing any knockouts from the enclosure, consult the local electrical code to determine the knockout requirements.

- Remove **deadfront (P)** by loosening the **securing screw (Q)** and lifting the **deadfront (P)** off the enclosure (*fig. 8*).
- To remove **knockouts (D)**, first strike the center of the knockout (*fig. 2*).
- Pry each **ring (E)** up, one at a time, and grip both ends with a pair of pliers.
- Use the pliers to bend the **rings (E)**, until they disconnect from the enclosure.

### Step 3: Enclosure Mounting

#### Surface Mounting

- Remove **mounting knockouts (F)** from the back of the enclosure (*fig. 3*).
- Use outdoor approved screws or nails (not provided) in the **mounting knockouts (F)** to secure the enclosure to the wall.

### Step 4: Phase, Neutral, and Ground Conductors

**WARNING:** Use **ONLY** approved fittings and clamps to avoid damage to wires.

- Bring the **phase, neutral, and ground** conductors into the enclosure through the overhead conduit opening or a bottom feed knockout.
- Connect the **phase, neutral, and ground** conductors to the appropriate terminals and torque to spec in the terminations table (*fig. 4*).

Fig. 1

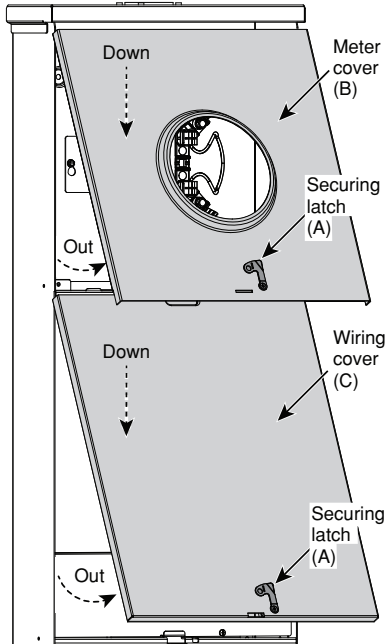

Fig. 2

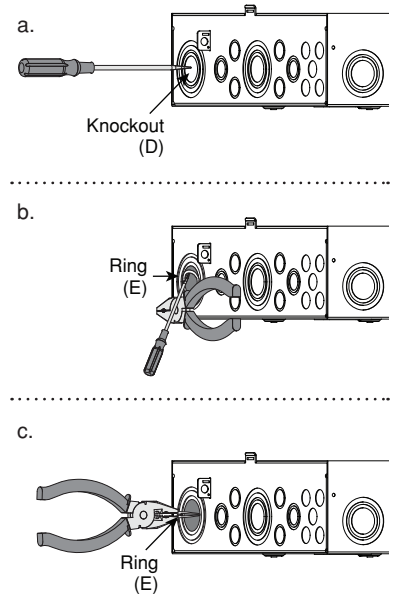

Fig. 3

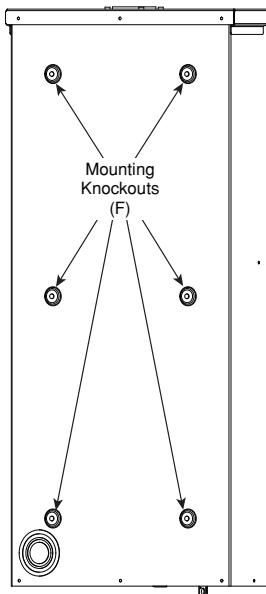
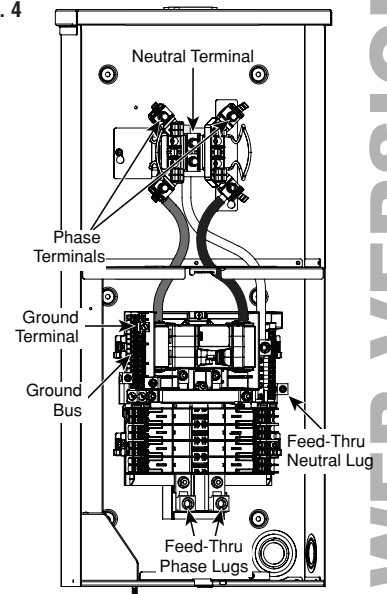

Fig. 4



WEB VERSION

### Step 5: Branch Circuit Breakers

**WARNING:** Leviton® circuit breakers **MUST BE** used with a Leviton circuit breaker enclosure.

- a. Strip and connect the **load phase (J)** and **load neutral (K)** wires to the **load terminals (L)**, and ground wire to the **ground bus (M)** of the circuit breaker enclosure (*fig. 5*). Strip wires and torque load terminals to spec in the terminations table.

**NOTE:** Ensure that the main breaker is in the OFF position before installing any branch circuit breakers.

**NOTE:** Ensure that all branch circuit breakers are in the OFF position before installing into the panel.

- b. Align the **hooks and guides (N)** of the branch circuit breaker with the panel, and press until breaker snaps into place (*fig. 6*).

### Step 6: Installing Deadfront

**NOTE:** **Twist-outs (O)** must be removed for each position that contains a branch circuit breaker. Fill any unused open spaces in cover using filler plates.

- a. To remove **twist-outs (O)**, first strike with a screwdriver, and then twist with pliers until detached (*fig. 7*).
- b. Install **deadfront (P)** by sliding it inward above the side wall protrusions on each side, at a 45-degree angle, until bottom portion of the **deadfront (P)** is seated into enclosure (*fig. 8*).
- c. Secure the bottom of the **deadfront (P)** with the **securing screw (Q)**.
- d. Apply circuit directory labels on the back of the door.
- e. Replace the meter and wiring compartment covers (*See Step 1*).

### Step 7: Complete the Installation

**WARNING:** Before providing power to the load center, check all electrical connections and confirm that the wiring is correct.

**WARNING:** Replace all doors and covers before connecting power to this equipment.

- a. Ensure that the main and all branch circuit breakers are in the OFF position. To energize, first turn ON the main breaker, and then turn ON each individual branch circuit breaker.

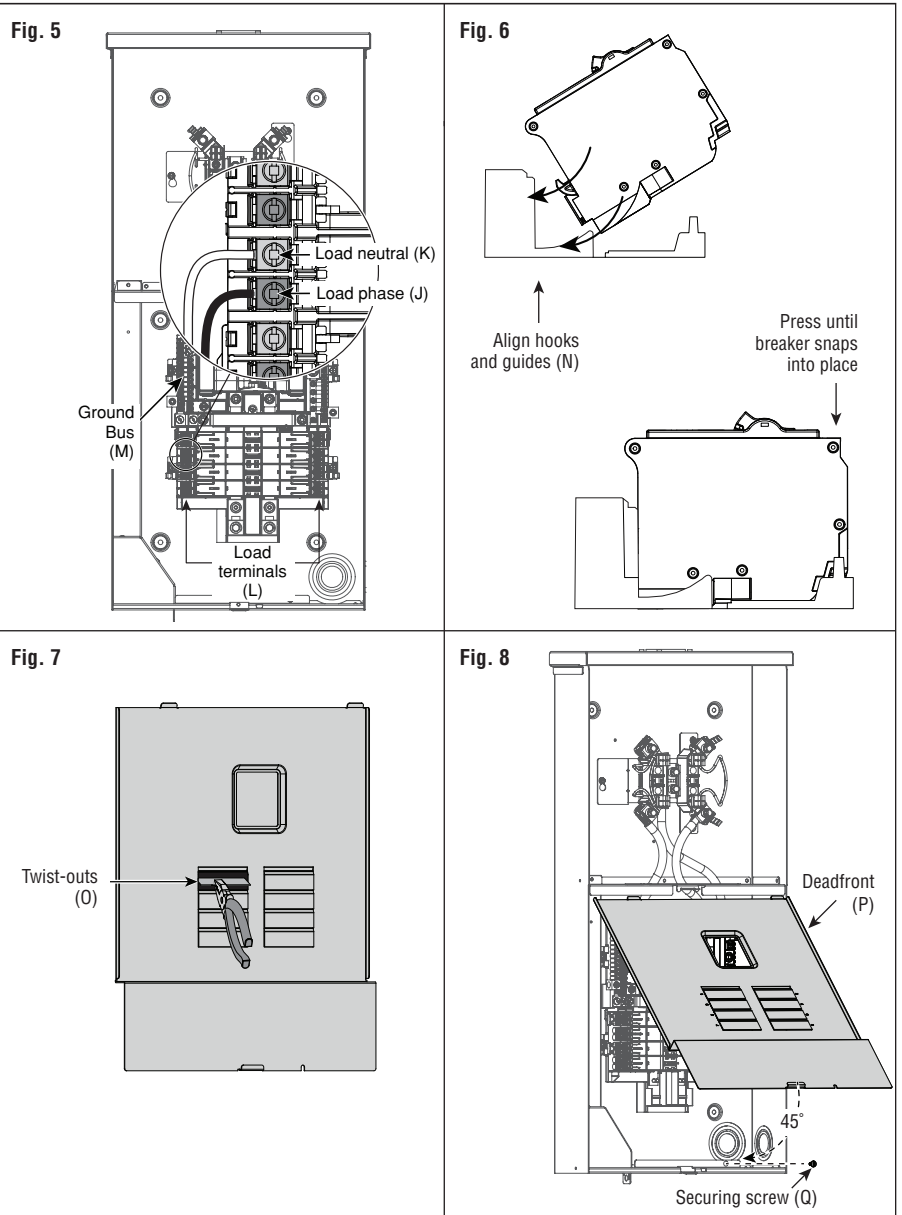

### TERMINATIONS

Termination Point	Wire Material	Wire Gauge	Strip Length	Torque
Meter Socket	Copper / Aluminum	#3 AWG - 350 MCM	1.1 in.	200 in.-lbs
Feed-Thru Phase	Copper / Aluminum	#3 AWG - 300 MCM	1.0 in.	375 in.-lbs
Feed-Thru Neutral	Copper / Aluminum	#4 AWG - 2/0 AWG	1.0 in.	120 in.-lbs.
Ground	Copper / Aluminum	#4 AWG - 2/0 AWG	0.75 in.	50 in.-lbs
Load Phase (brass) & Load Neutral (silver)	Copper	(1) #4 AWG - #8 AWG, Stranded	0.4 in.	45 in.-lbs
		(1) #10 AWG, Solid or Stranded		35 in.-lbs
		(2) #14 AWG - #10 AWG, Solid		35 in.-lbs
		(1) #12 AWG - #14 AWG, Solid or Stranded		25 in.-lbs.
	Aluminum	(2) #14 AWG or (2) #12 AWG, Stranded		25 in.-lbs.
		(1) #4 AWG - #6 AWG, Stranded		45 in.-lbs
		(1) #8 AWG, Stranded		35 in.-lbs
		(2) #12 AWG - #10 AWG, Solid		35 in.-lbs
Neutral & Equipment Ground Bar	Copper/Aluminum	(1) #10 AWG - #12 AWG, Solid	0.5 in.	25 in.-lbs.
		(2) #12 AWG or (2) #10 AWG, Solid		25 in.-lbs.
	Copper	(1) #6 AWG - #4 AWG, Stranded		35 in.-lbs
		(1) #8 AWG, Stranded		25 in.-lbs
		(1) #14 AWG - #10 AWG Solid or Stranded		20 in.-lbs
		(2) #14 AWG - #10 AWG, Solid or Stranded		25 in.-lbs
	Aluminum	(1) #14 AWG and (1) #12 AWG, Solid		25 in.-lbs
		(1) #14 AWG and (1) #10 AWG, Solid or Stranded		25 in.-lbs
Neutral Bar	Copper/Aluminum	(1) #12 AWG and (1) #10 AWG, Solid	25 in.-lbs	
		(2) #12 AWG - #10 AWG, Solid	20 in.-lbs	
	Copper	(1) #12 AWG and (1) #10 AWG, Solid	20 in.-lbs	
		(2) #12 AWG - #10 AWG, Solid	20 in.-lbs	
Aluminum	#4 AWG - #1 AWG, Stranded	50 in.-lbs		
	#8 AWG - #6 AWG, Stranded	30 in.-lbs		
Copper	#14 AWG - #10 AWG, Solid or Stranded	30 in.-lbs		
	Aluminum	#12 AWG - #10 AWG, Solid	30 in.-lbs	