

WARNINGS AND CAUTIONS:

- **TO AVOID FIRE, SHOCK, OR DEATH; TURN OFF POWER AT CIRCUIT BREAKER OR FUSE AND TEST THAT THE POWER IS OFF BEFORE WIRING!**
- To be installed and/or used in accordance with electrical codes and regulations.
- To avoid overheating and possible damage to this device and other equipment, **DO NOT** install to control a receptacle, a motor, or a transformer-operated appliance other than applicable specified lighting load: Incandescent and LED.
- When using in a 3-way application use one sensor and one standard 3-way switch. Cannot be used with another sensor, or in a 4-way application.

WARNINGS AND CAUTIONS:

- If you are not sure about any part of these instructions, consult an electrician.
- Clean outer surface gently with damp cloth only. **DO NOT** use soaps or cleaning liquids.
- No user serviceable components. **DO NOT** attempt to service or repair.
- Use this device **WITH COPPER OR COPPER CLAD WIRE ONLY.**

TOOLS NEEDED TO INSTALL YOUR DEVICE

- Slotted/Phillips Screwdriver
- Electrical Tape
- Pliers
- Pencil
- Cutters
- Ruler

Changing the color of your device:

Your device may include color options. To change color of the face proceed as follows:

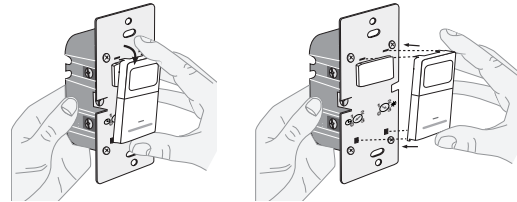

Push down tabs per diagram, one at a time and rotate forward to release. Attach new face by inserting bottom hinge tabs, then pivot and snap the color kit to attach.

FEATURES

- Cat. No. IPS06 and IPV06 have a sensing area of coverage of 30 ft. x 30 ft., and a sensing angle of 180° (see Sensing Area Coverage figure on page 2).
- Adjustable light and time-delay controls are located on the front of the device (See adjustment setting section on page 2 for details).
- LED indicator is used to alert the user of the status of the device.
- Adjustable Time Delay setting for 30 seconds, 5 min, 15 min & 30 min.
- Occupancy sensor can be converted to a vacancy sensor (See adjustment settings on page 2).

LOCATION / MOUNTING

The device responds to temperature changes and care should be taken when mounting the device. **DO NOT** mount directly above a heat source, in a location where hot or cold drafts will blow directly on the sensor, or where unintended motion (e.g., hallway traffic) will be within sensor's field-of-view.

INSTALLING YOUR DEVICE

NOTE: Use check boxes when Steps are completed.

Step 1 WARNING: TO AVOID FIRE, SHOCK, OR DEATH; TURN OFF POWER at circuit breaker or fuse and test that power is off before wiring!

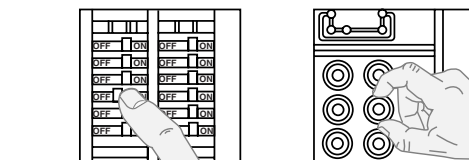

Step 2 Identifying your wiring application (most common):

NOTE: If the wiring in the wall box does not resemble any of these configurations, consult an electrician.

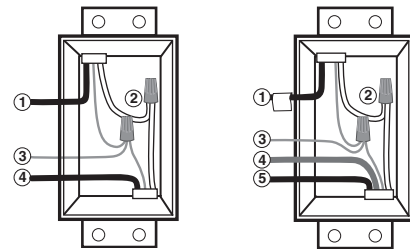

Single-Pole

1. Line (Hot)
2. Neutral
3. Ground
4. Load

3-Way

1. Line or Load (See important instruction below)
2. Neutral
3. Ground
4. First Traveler – note color
5. Second Traveler – note color

IMPORTANT: For 3-way applications, note that one of the screw terminals from the old switch being removed will usually be a different color (Black) or labeled Common. Tag that wire with electrical tape and identify as the common (Line or Load) in both the sensor wall box and remote wall box.

Step 3 Preparing and connecting wires:

This device can be wired using side wire terminal screws. Choose appropriate wire stripping specifications accordingly.

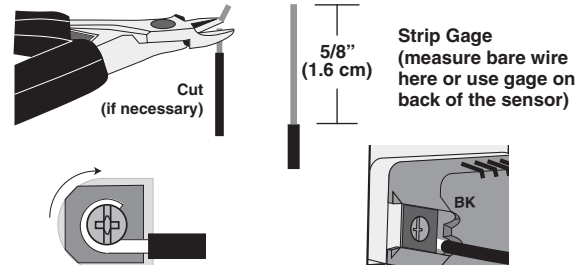

Side Wire Connection

Side wire terminals accept #14-12 AWG solid copper wire only.

Back Wire Connection

Back wire openings use #14-12 AWG solid copper wire only.

- Make sure that the ends of the wires from the wall box are straight (cut if necessary).
- Remove insulation from each wire in the wall box as shown.
- For Single Pole Application, go to Step 4A.
- For 3-Way Application with the sensor on the Load side, go to Step 4B.
- For 3-Way Application with the sensor on the Line side, go to Step 4C.

Step 4 Single Pole Wiring Application:

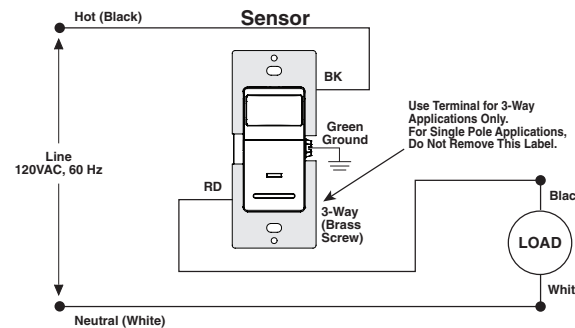
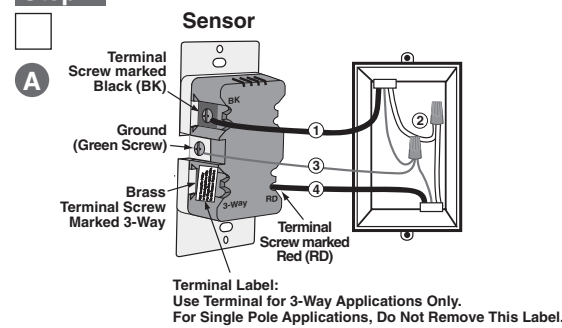

WIRING SENSOR:

Connect wires per WIRING DIAGRAM as follows:

- Green or bare copper wire in wall box to Green terminal screw.
- Line Hot wall box wire to terminal screw marked "BK".
- Load wall box wire to terminal screw marked "RD".
- Terminal screw marked "3-way" should have Red insulation label affixed.
- NOTE: If insulating label is not affixed to terminal screw marked "3-way", use electrical tape to cover.
- Proceed to Step 5.

3-Way Wiring with 3-Way Switch Application:

When connecting the sensor for 3-way control, first choose which wall switch location the sensor will be installed in. Next, identify which electrical box has the line connection. If the line connection is in the box where the standard 3-way switch is located, use wiring diagram 4B. If the line connection is in the box where the sensor is located, use wiring diagram 4C.

NOTE: A pair of short pigtail wires will be needed for connection to the 3-way switch.

B Sensor is located in electrical box with LOAD connection:

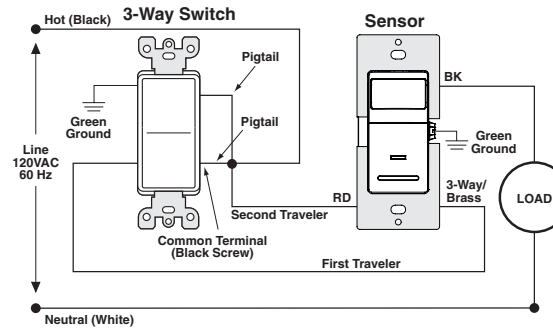
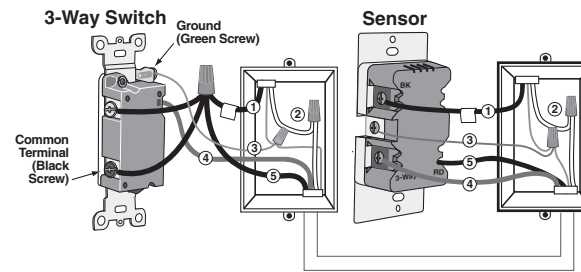

WIRING SWITCH:

Connect wires per WIRING DIAGRAM as follows:

- Green or bare copper wire in wall box to Green terminal screw.
- One pigtail wire to the Black screw terminal marked "COM" and one pigtail wire to the Brass terminal (same side of switch).
- Connect the following 4 wires using an appropriately sized wire nut:
 1. Common/Line wire (identified in step 2).
 2. Second Traveler wire (note color from step 2).
 3. Two pigtail wires from the 3-way switch.
- First Traveler wall box wire (note color from step 2) to Brass screw terminal on the switch (opposite side from the Black screw).

WIRING SENSOR:

Connect wires per WIRING DIAGRAM as follows:

- Green or bare copper wire in wall box to Green terminal screw.
- Common/Load wall box wire identified when removing old switch (step 2) to terminal screw marked "BK".
- First Traveler wall box wire (note color from step 2) to terminal screw marked "3-way".
- Second Traveler wall box wire (note color from step 2) to terminal screw marked "RD". This Traveler from the switch must go to the terminal screw on the sensor marked "RD".

C Sensor is located in electrical box with LINE connection:

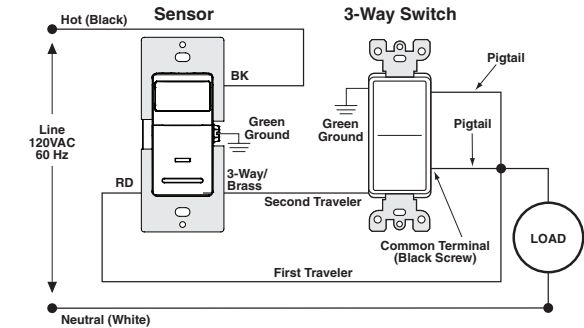
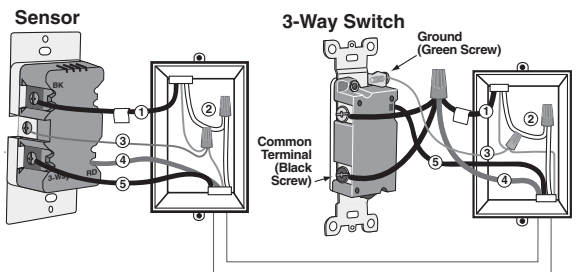

WIRING SENSOR:

Connect wires per WIRING DIAGRAM as follows:

- Green or bare copper wire in wall box to Green terminal screw.
- Common/Line wall box wire identified when removing old switch (step 2) to terminal screw marked "BK".
- First Traveler wall box wire (note color from step 2) to terminal screw marked "RD".
- Second Traveler wall box wire (note color from step 2) to terminal screw marked "3-way".

WIRING SWITCH:

Connect wires per WIRING DIAGRAM as follows:

- Green or bare copper wire in wall box to Green terminal screw.
- One pigtail wire to the Black screw terminal marked "COM" and one pigtail wire to the brass terminal (same side of switch)
- Connect the following 4 wires using an appropriately sized wire nut:
 1. Common/Load wire (identified in step 2).
 2. First Traveler wire (note color from step 2).
 3. Two pigtail wires from the 3-Way switch.
- Second Traveler wall box wire (note color from step 2) to Brass screw terminal on the switch (opposite side from the Black screw).

Step 5 Testing your Device prior to mounting in wall box:

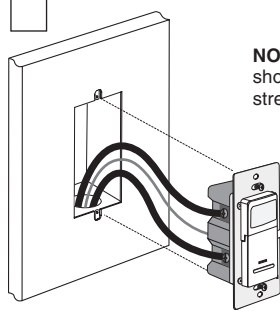

NOTE: Dress wires with a bend as shown in diagram in order to relieve stress when mounting device.

- Position all wires to provide room in outlet wall box for device.
- Ensure that the word "TOP" is facing up on device strap.
- Partially screw in mounting screws in wall box mounting holes.

- Restore power at circuit breaker or fuse.
- For IPS06 lights will automatically turn ON after power is applied.
- For IPV06 press and release pushpad to turn the lights ON.

See **Locator Light Status chart** to confirm the operational state of the device.

If lights still do not turn ON, refer to the **TROUBLESHOOTING** section.

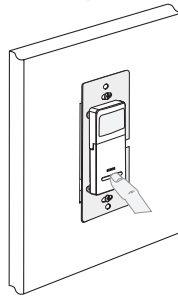

Step 6 Device Mounting: TURN OFF POWER AT CIRCUIT BREAKER OR FUSE.

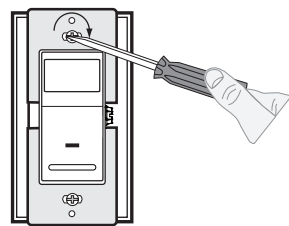

Installation may now be completed by tightening mounting screws into wall box. Attach wallplate.

Step 7 Restore Power: Restore power at circuit breaker or fuse.

Installation is complete.

OPERATION

IPS06

Auto On: Lights will automatically turn ON when room is occupied or motion is detected. The IPS06 will switch lights OFF when no motion is detected in un-occupied room after set period of time.

Time delay adjustment: Refer to section on Adjustment Settings.

Light level adjustment: Refer to section on Adjustment settings.

Manual ON: The IPS06 will manually turn ON lights or the load by depressing the push pad on the device.

IPV06

Manual ON: The IPV06 requires the user to manually turn ON lights or the load by depressing the push pad on the device.

The lights or load will automatically turn OFF when the room is left un-occupied for a set period of time.

The IPV06 can also be turned off manually by depressing the push pad.

Time delay adjustment: refer to section on Adjustment settings

NOTE: In a 3-way application, the 3 way switch provides the ability to manually switch the load ON from a second location. The sensor will time out and switch the load OFF once motion is no longer detected and the time delay expires.

Locator Light LED:

IPS06: LED blinks when motion is detected and if the load is ON or OFF.

IPV06: LED blinks when motion is detected and when load is ON. LED will remain illuminated when load is OFF.

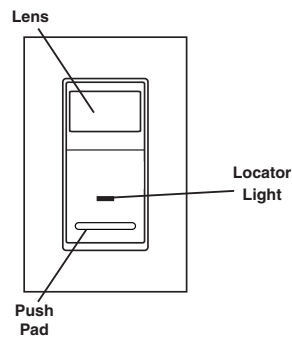

LOCATOR LIGHT STATUS		
LOAD	IPS06	IPV06
OFF	Blinking	Lit
ON	Blinking	Blinking

ADJUSTMENT SETTINGS

1. With power restored and wallplate removed, remove face of device to expose setting controls, see color change instructions in page 1. Use a small screwdriver to adjust the light sensitivity and time settings on the device as follows:

Light Level Adjustment:

- Adjust the light level dial clockwise. Lights will turn ON in lighter conditions.
- Adjust the light level dial counter clockwise. Lights will turn ON in less lighting conditions.
- Adjusting light level fully counter clockwise will require manual operation of the sensor.

Time Selection:

- Adjust the time selector dial to the desired length of time the lights are to remain ON. Lights will remain ON from 30 seconds to 30 minutes after the room is vacated.
 - Adjust the time selector dial clockwise to increase the duration of the ON time up to 30 minutes.
 - Adjust the time selector dial counter clockwise to decrease the duration of the ON time down to 30 sec.
2. Test that the light level and time selection are as desired. If not, repeat adjustments until satisfied.
 3. Mount wallplate. **INSTALLATION IS COMPLETE.**



Settings	Time
0	30 Sec
1	5 Min
2	15 Min
3	30 Min

NOTE: To operate the IPS06 as a vacancy sensor (manual ON/Auto OFF) - rotate the light level adjustment fully counter clockwise.

SENSING AREA COVERAGE

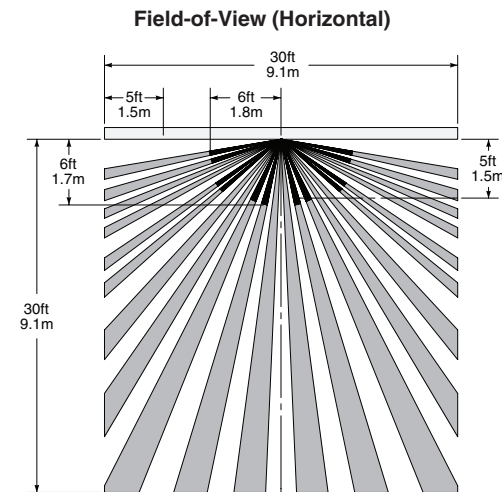

Side (Vertical) Field-of-View

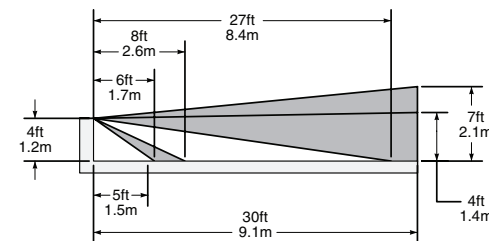

TROUBLESHOOTING

Lights do not switch ON - IPS06:

- Motion is beyond sensing range, move closer to switch.
- Adjust the light level adjustment toward lighter or darker, depending on room conditions.

Lights always stay ON:

- Check time delay settings and compare to how long the lights stay ON.
- Be sure that no motion occurs in coverage area for time selected.
- Check that switch is not installed near a heat source (e.g., stove, lights, heat vents) or detecting motion from an adjacent area (e.g., hallway traffic). If so, switch may have to be relocated.

Lights do not turn ON - IPV06:

- Check that switch is installed correctly.
- Check that power is ON.
- Check that light bulb is functioning.

NOTE: If problems continue, consult an electrician.

For additional information, contact Leviton's Techline at 1-800-824-3005 or visit Leviton's website at www.leviton.com

This product is covered by U.S. Pat. No. 7,924,155 and corresponding foreign patents.
© 2012 Leviton Manufacturing Co., Inc.
All Rights Including Trade Dress Rights Reserved

FCC COMPLIANCE STATEMENT

This device complies with Part 15 of the FCC Rules. Operation is subject to following two conditions: (1) this device may not cause harmful interference, and (2) this device must accept any interference received, including interference that may cause undesired operation of the device.

This equipment has been tested and found to comply with the limits for a Class B Digital Device, pursuant to Part 15 of the FCC Rules. These limits are designed to provide reasonable protection against harmful interference in a residential installation. This equipment generates, uses, and can radiate radio frequency energy and, if not installed and used in accordance with the instructions, may cause harmful interference to radio communications. However, there is no guarantee that interference will not occur in a particular installation. If this equipment does cause harmful interference to radio or television reception, which can be determined by turning the equipment OFF and ON, the user is encouraged to try to correct the interference by one or more of the following measures:

- Reorient or relocate the receiving Antenna.
- Increase the separation between the equipment and the receiver.
- Connect the equipment into an outlet on a circuit different from that to which the receiver is connected.
- Consult the dealer or an experienced radio/tv technician for help.

FCC CAUTION

Any changes or modifications not expressly approved by Leviton Manufacturing Co., Inc., could void the user's authority to operate the equipment.

FOR CANADA ONLY

For warranty information and/or product returns, residents of Canada should contact Leviton in writing at **Leviton Manufacturing of Canada Ltd to the attention of the Quality Assurance Department, 165 Hymus Blvd, Pointe-Claire (Quebec), Canada H9R 1E9** or by telephone at 1 800 405-5320.

LIMITED 5 YEAR WARRANTY AND EXCLUSIONS

Leviton warrants to the original consumer purchaser and not for the benefit of anyone else that this product at the time of its sale by Leviton is free of defects in materials and workmanship under normal and proper use for five years from the purchase date. Leviton's only obligation is to correct such defects by repair or replacement, at its option, if within such five year period the product is returned prepaid, with proof of purchase date, and a description of the problem to **Leviton Manufacturing Co., Inc., Att: Quality Assurance Department, 201 North Service Road, Melville, New York 11747**. This warranty excludes and there is disclaimed liability for labor for removal of this product or reinstallation. This warranty is void if this product is installed improperly or in an improper environment, overloaded, misused, opened, abused, or altered in any manner, or is not used under normal operating conditions or not in accordance with any labels or instructions. **There are no other or implied warranties of any kind, including merchantability and fitness for a particular purpose**, but if any implied warranty is required by the applicable jurisdiction, the duration of any such implied warranty, including merchantability and fitness for a particular purpose, is limited to five years. **Leviton is not liable for incidental, indirect, special, or consequential damages, including without limitation, damage to, or loss of use of, any equipment, lost sales or profits or delay or failure to perform this warranty obligation.** The remedies provided herein are the exclusive remedies under this warranty, whether based on contract, tort or otherwise.