

# INSTALLATION INSTRUCTIONS

## Outdoor Meter Main, Ring-Type, No Bypass, OH/UG Service Entrance Enclosure

### IMPORTANT SAFETY INSTRUCTIONS - READ ALL INSTRUCTIONS BEFORE USING.

#### ⚠ WARNINGS

- **TO AVOID FIRE, SHOCK, OR DEATH, TURN OFF POWER SUPPLYING THIS EQUIPMENT AND CONFIRM POWER IS OFF,** before installing, removing, or servicing this equipment.
- This equipment **MUST BE** installed and serviced by an electrician.
- Leviton® circuit breakers **MUST BE** used with a Leviton circuit breaker enclosure.
- Use **ONLY** approved fittings and clamps to avoid damage to wires.
- Before providing power to the load center, check all electrical connections and confirm that the wiring is correct.
- Replace all doors and covers before connecting power to this equipment.
- To be installed and/or used in accordance with electrical codes and regulations.
- **SAVE THESE INSTRUCTIONS.**

#### LIMITED PRODUCT WARRANTY

For Leviton's limited product warranty, go to [www.leviton.com](http://www.leviton.com). For a printed copy of the warranty, you may call 1-800-323-8920. Patents covering this product, if any, can be found on [Leviton.com/patents](http://Leviton.com/patents).

#### INSTALLATION

**WARNING: TO AVOID FIRE, SHOCK, OR DEATH, TURN OFF POWER SUPPLYING THIS EQUIPMENT AND CONFIRM POWER IS OFF,** before installing, removing, or servicing this equipment.

##### Step 1: Remove meter and wiring compartment covers.

- Slide **securing latch (A)** upward (Figure 1).
- Slide **meter cover (B)** down and out.
- Slide **wiring compartment cover (C)** down and out.

##### Step 2: (Optional) Wire bottom feed.

**NOTE:** Install the closing plate (included) to the overhead opening of the enclosure, for bottom feed applications.

**NOTE:** For bottom feed applications, wires and conductors should be run through the wire trough on the left side. For top feed applications, the wire trough can be removed, if desired, by removing the top securing screw, and sliding upward and out.

**NOTE:** Before removing any knockouts from the enclosure, consult the local electrical codes to determine the knockout requirements.

- Remove **deadfront (P)** by loosening the **securing screw (Q)** and lifting the **deadfront (P)** off the enclosure (Figure 10).
- To remove **knockouts (D)**, first strike the center of the knockout (Figure 2).
- Pry each **ring (E)** up, one at a time, and grip both ends with a pair of pliers.
- Use pliers to bend the **rings (E)**, until they disconnect from enclosure.

##### Step 3: Mount the enclosure.

###### Surface Mounting

- Remove the **service entrance compartment cover (F)** by unscrewing two (2) **screws (G)** that are securing it to the enclosure (Figure 3).
- Remove **mounting knockouts (H)** from the back of the enclosure (Figure 4).
- Use outdoor approved screws or nails (*not provided*) in the **mounting knockouts (H)**, to secure the enclosure to the wall.

##### Step 4: Connect phase, neutral, and ground conductors.

**WARNING:** Use **ONLY** approved fittings and clamps to avoid damage to wires.

- Bring the **phase, neutral, and ground** conductors into the enclosure, through the overhead conduit opening or a bottom feed knockout (Figure 5).
- Connect the **phase, neutral, and ground** conductors to the appropriate terminals, and torque them to the specifications in the **Terminations Table**.
- Re-install the **service entrance compartment cover (F)** by placing the top edge under the **enclosure flange (I)**, and secure it using two (2) **screws (G)** (Figure 6).

##### Step 5: Install branch circuit breakers.

**WARNING:** Leviton® circuit breakers **MUST BE** used with a Leviton circuit breaker enclosure.

- Strip and connect the **load phase (J)** and **load neutral (K)** wires to the **load terminals (L)**, and ground wire to the **ground bus (M)** of the circuit breaker enclosure (Figure 7). Strip wires and torque load terminals to specifications in **Terminations Table**.  
**NOTE:** Ensure that the main breaker is in the OFF position before installing any branch circuit breakers.  
**NOTE:** Ensure that all branch circuit breakers are in the OFF position before installing into the panel.
- Align the **hooks and guides (N)** of the branch circuit breaker with the panel, and press until breaker snaps into place (Figure 8).

Figure 1

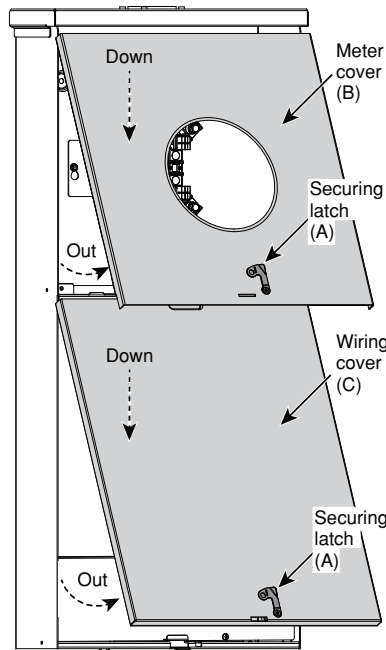

Figure 2

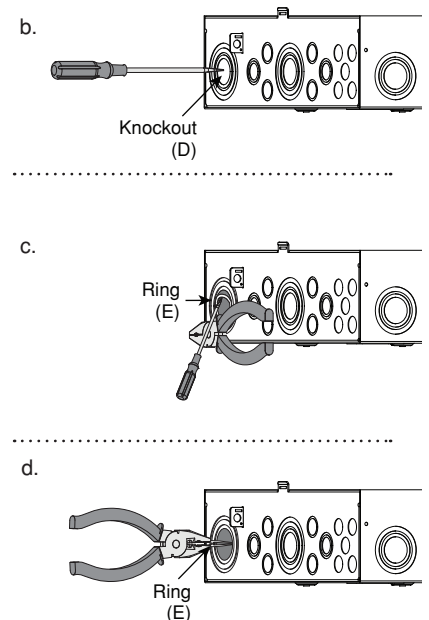

Figure 3

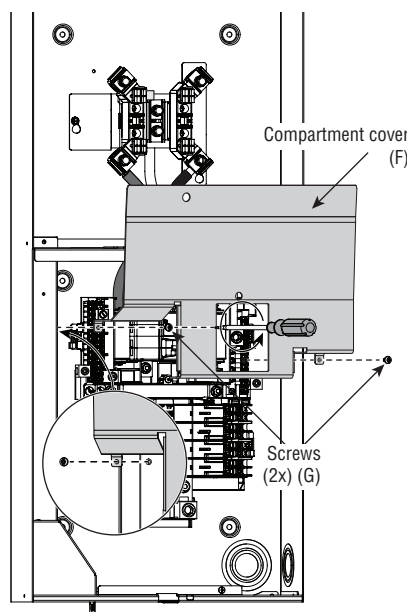
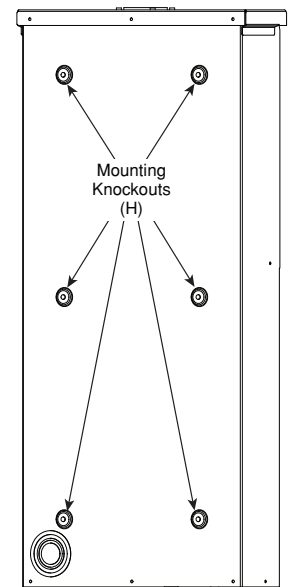

Figure 4



**Step 6: Install the deadfront.**

**NOTE:** Twist-outs (O) must be removed for each position that contains a branch circuit breaker. Fill any unused open spaces in the cover, using filler plates.

- To remove twist-outs (O), first strike with a screwdriver, and then twist with pliers until detached (Figure 9).
- Install deadfront (P) by sliding it inward above the side wall protrusions on each side, at a 45-degree angle, until bottom portion of the deadfront (P) is seated into enclosure (Figure 10).
- Secure the bottom of the deadfront (P) with the securing screw (Q).
- Apply circuit directory labels on the back of the door.
- Replace the meter and wiring compartment covers (Refer to Step 1).

**Step 7: Complete the installation.**

**WARNING:** Before providing power to the load center, check all electrical connections and confirm that the wiring is correct.

**WARNING:** Replace all doors and covers before connecting power to this equipment.

**NOTE:** Sealing Ring is not included with Load Center. Once the meter is installed, accessory part # LRING or utility-supplied Sealing Ring must be installed to secure the meter to the cover.

- Ensure that the main and all branch circuit breakers are in the OFF position. To energize, first turn ON the main breaker, and then turn ON each individual branch circuit breaker.

**TERMINATIONS**

Termination Point	Wire Material	Wire Gauge	Strip Length	Torque
Meter Socket	Copper / Aluminum	#3 AWG - 350 MCM	1.1 in.	200 in.-lbs.
Feed-Thru Phase	Copper / Aluminum	#3 AWG - 300 MCM	1.0 in.	375 in.-lbs.
Feed-Thru Neutral	Copper / Aluminum	#4 AWG - 2/0 AWG	1.0 in.	120 in.-lbs.
Ground	Copper / Aluminum	#4 AWG - 2/0 AWG	0.75 in.	50 in.-lbs.
Load Phase (brass) & Load Neutral (silver)	Copper	(1) #4 AWG - #8 AWG, Stranded	0.4 in.	45 in.-lbs.
		(1) #10 AWG, Solid or Stranded		35 in.-lbs.
		(2) #14 AWG - #10 AWG, Solid		35 in.-lbs.
		(1) #12 AWG - #14 AWG, Solid or Stranded		25 in.-lbs.
	Aluminum	(2) #14 AWG or (2) #12 AWG, Stranded		25 in.-lbs.
		(1) #4 AWG - #6AWG, Stranded		45 in.-lbs.
		(1) #8 AWG, Stranded		35 in.-lbs.
		(2) #12 AWG - #10 AWG, Solid		35 in.-lbs.
Neutral & Equipment Ground Bar	Copper/ Aluminum	(1) #6 AWG - #4 AWG, Stranded	0.5 in.	35 in.-lbs.
		(1) #8 AWG, Stranded		25 in.-lbs.
	Copper	(1) #14 AWG - #10 AWG, Solid or Stranded		20 in.-lbs.
		(2) #14 AWG - #10 AWG, Solid or Stranded		20 in.-lbs.
		(1) #14 AWG and (1) #12 AWG, Solid		20 in.-lbs.
		(1) #14 AWG and (1) #10 AWG, Solid or Stranded		20 in.-lbs.
		(1) #12 AWG and (1) #10 AWG, Solid		20 in.-lbs.
		(2) #12 AWG - #10 AWG, Solid		20 in.-lbs.
Aluminum	(1) #12 AWG and (1) #10 AWG, Solid	20 in.-lbs.		
	Copper/ Aluminum	#4 AWG - #1 AWG, Stranded	0.5 in.	50 in.-lbs.
		#8 AWG - #6 AWG, Stranded		30 in.-lbs.
		Copper		#14 AWG - #10 AWG, Solid or Stranded
Aluminum	#12 AWG - #10 AWG, Solid	30 in.-lbs.		

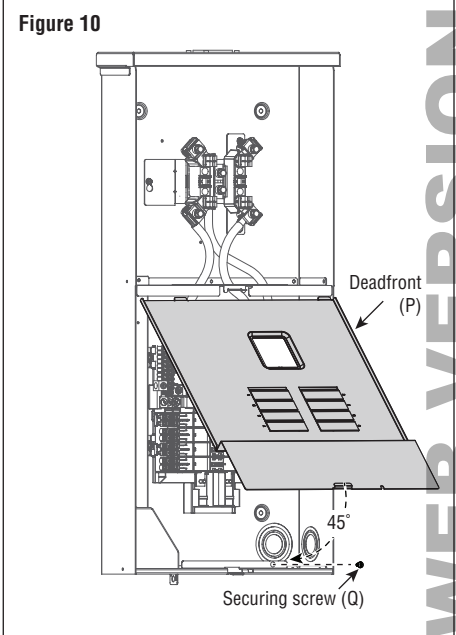
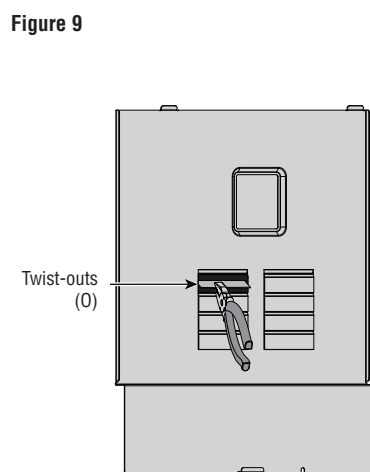
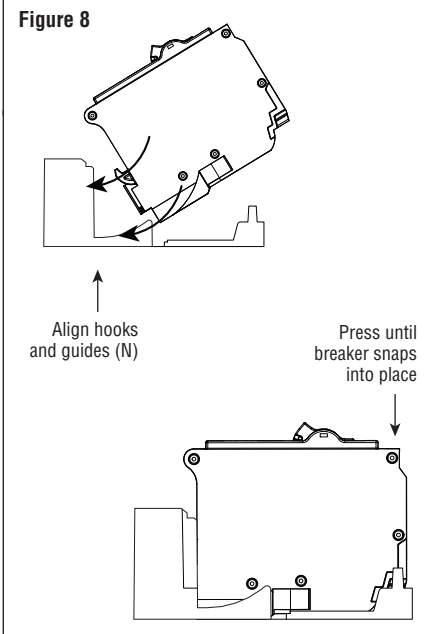
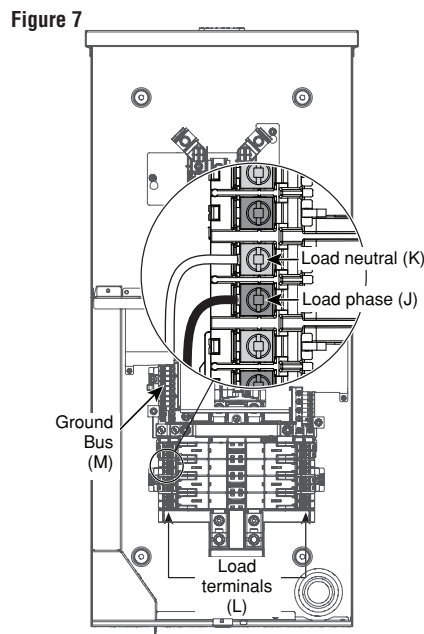
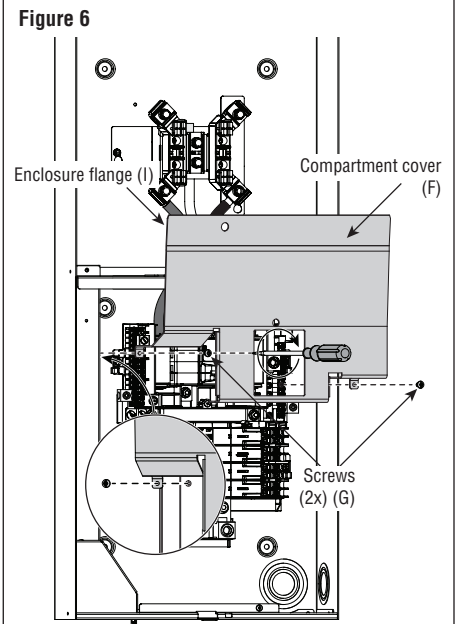
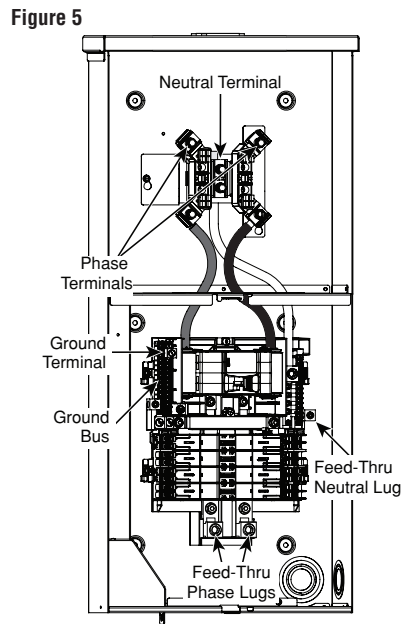

WEB VERSION