

WHITE PAPER



## 4 Steps to Successfully Deploying an Enterprise Wireless Network

From planning to cabling system choices

**Yuna Shin**  
Senior Product Manager

## TABLE OF CONTENTS

STEP 1: Know the technology	3
STEP 2: Understand which devices will use the wireless network and your capacity needs	6
STEP 3: Understand what type of wireless technology is best for your environment and the building layout	6
STEP 4: Make cabling and connectivity choices	7

**What's the best way to prepare for emerging wireless network demands? If your organization made a relatively recent upgrade to its wireless network, it might not be ready for another update to adopt the latest wireless networking technology. Perhaps a short-term solution would meet your needs. Or, maybe your organization is ready to invest in the newest system — one with the bandwidth and infrastructure that will allow the business to keep up with rising data use for years to come.**

Leviton recommends following four important steps to successfully deploy a wireless enterprise network.

- 1. Develop an understanding of wireless technology.**
- 2. Determine device types and capacity needs.**
- 3. Consider your environment and building layout.**
- 4. Choose cabling and connectivity that will best suit your goals.**

The first step is a general information gathering phase: You want to understand the technology and the differences between various wireless specifications. Steps two through four fall under the “planning” umbrella — they're key to any successful wireless setup.



## **STEP 1:** **KNOW THE TECHNOLOGY**

### **History and Evolution of Wireless Speeds**

Twenty years ago, first generation wireless wasn't considered a necessity. But the technology has evolved to a point where a robust wireless network is mandatory in many building locations; it's as crucial to a healthy enterprise as computers and smartphones. Organizations in a variety of sectors have seen a dramatic increase in network speeds required to operate effectively. These organizations include office environments, manufacturing facilities, schools and campuses, and hospitals.

The advent of mobile devices significantly increased the amount of IP traffic. And the rise of the Internet of Things — connecting millions of everyday devices — will increase it even more. This demand has led to recent updates to wireless network standards and technologies, with faster speeds and greater bandwidth.

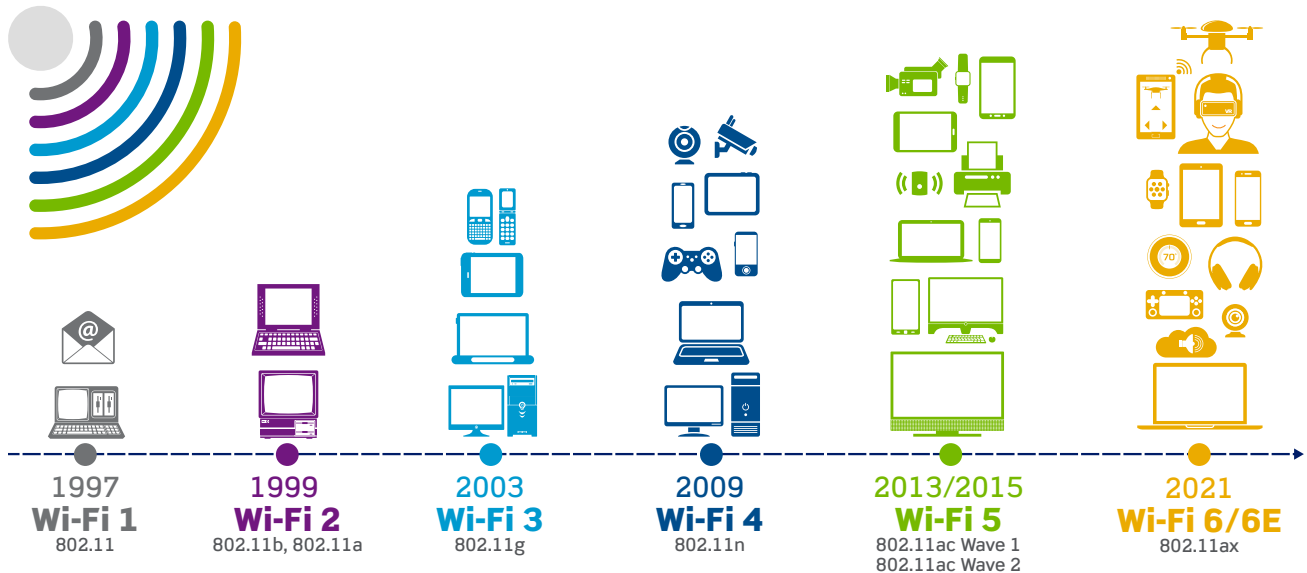

An easy way to visualize how a more robust Wi-Fi network increases workplace efficiency is to take a look at the amount of time it takes for a 5 gigabyte file to download. In 1999, the speed for Wi-Fi was 54 megabits per second (Mb/s). A 5 gigabyte file took about 15 minutes to transfer. But now, that same file can download in less than 5 seconds at the theoretical maximum speed of 10 gigabits per second (Gb/s) with 802.11ax technology.

### What determines wireless speed?

Wireless speed relies on:

1. Channel bandwidth
2. Spatial streams (related to antenna configuration)
3. Signal modulation

**Channel Bandwidth** — Wireless networks can run on 20, 40, 80, or 160 MHz channels, within a 2.4 GHz or 5 GHz band. Older Wi-Fi such as 802.11b and 802.11g use the narrower 2.4 GHz, while newer Wi-Fi can run on 5 GHz. The 5 GHz frequency band is wider, which means it allows for more capacity. Think of it as wider roads — they allow more traffic (information) to move. In addition to capacity, signals over 5 GHz are much cleaner and faster, as the channel is less congested than 2.4 GHz channels.

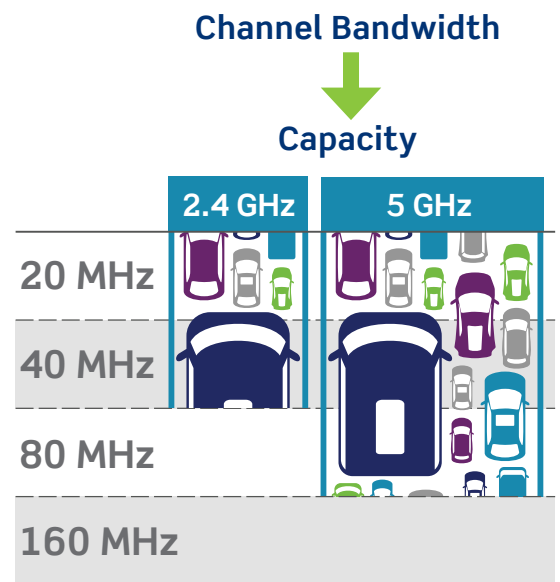

Wider channels allow more traffic (information) to move.

**Spatial Streams** — Early 802.11 networks used a single antenna and one data stream, which means there was only one transmitting antenna sending a signal to a receiving antenna through one path. 802.11n made improvements, supporting up to 4 antennas and 4 spatial streams for parallel data transfers within the same channel. Technology called multiple-input multiple-output (MIMO) allows multiple data streams on the same channel, instead of sending signals to one device at a time. 802.11ac went a step further, allowing up to 8 antennas and 8 spatial streams for increased efficiency. It also begins to support multi-user MIMO (MU-MIMO), which allows a wireless access point to transmit independent data streams to multiple clients simultaneously.

The communication technique continued to improve with the implementation of 16 spatial streams and OFDMA (Orthogonal frequency-division multiple access) in 802.11ax, which allows more intelligent data allocation to clients with higher throughput.

## Comparing spatial streams and antenna configurations

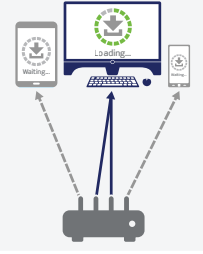
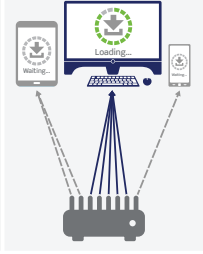
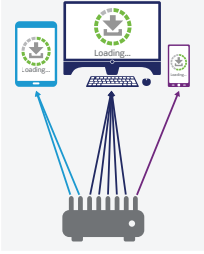
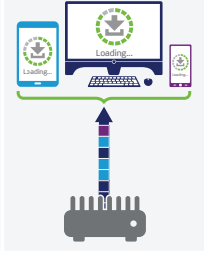
	802.11g	802.11n	802.11ac		802.11ax
			Wave 1	Wave 2	
<b>Spatial Streams</b>	1	4	8	8	16
<b>Channel Configuration</b>					
	SISO	4x4 MIMO	8x8 MIMO	8x8 MU MIMO	Downlink MU-MIMO & OFDMA

**Signal Modulation** — Over the last decade, signal modulation techniques have evolved to improve the speed of wireless networks. Earlier renditions of 802.11 networks that used older techniques — such as QPSK, 16 QAM, or 64 QAM — have fewer bits per symbol, while 802.11ac uses 256 QAM, allowing a 33% faster speed over 802.11n with 64 QAM. 802.11ax with 1024 QAM increases the speed by an additional 25% over 802.11ac.

The combination of increased capacity, concentrated signal paths, and enhanced modulation techniques in newer Wi-Fi has significantly improved wireless performance. However, there is one trade-off that must be considered: coverage. While newer WAPs provide faster and cleaner signals by running on higher frequency bands, they may not provide wider coverage because of the shorter wavelength in these frequency bands. A shorter wavelength means that the signal has a harder time moving through walls or furniture, so you have to be closer to the WAP to get a good signal. Also, while higher QAM gives you faster speed, you also have to be closer to the WAP to receive it, since there are more symbols in a constellation, as shown below.

There are trade-offs between options, so it's important to understand the technology and invest enough time during the planning stage to make the right choice for your business. Proper planning will help you maximize the benefits of an advanced wireless network.





## STEP 2: UNDERSTAND WHICH DEVICES WILL USE THE WIRELESS NETWORK AND YOUR CAPACITY NEEDS

Answering some important questions about the makeup of your applications will assist with proper planning of the infrastructure you need. What types of devices will be accessing the wireless network and how many people will be using Wi-Fi at one time? Will hospital imaging machines or smart machines on a warehouse floor dominate your bandwidth? Will the Wi-Fi serve people using smartphones in a waiting room? Or maybe your setting is a huge university, where students will be using laptops and tablets in a lecture hall or dorm. Needs can vary from building to building.

When trying to determine how to deploy wireless networks, you need to carefully plan based on the business needs, and the size and application types that the network will serve. Based on that information, you can make a better decision as to which wireless technology makes sense for you.

### Consider the devices used in different areas of your facility



#### Commercial

Laptops  
Computers  
Tablets  
Smartphones  
Video Conferencing  
VoIP



#### Education

Laptops  
Computers  
Tablets  
Smartphones



#### Health Care

Imaging Devices  
Laptops  
Computers  
Tablets  
Smartphones  
Tablets  
RTLS



#### Manufacturing

Inventory Control  
Line automation  
Smart Machines



## STEP 3: UNDERSTAND WHAT TYPE OF WIRELESS TECHNOLOGY IS BEST FOR YOUR ENVIRONMENT AND THE BUILDING LAYOUT

Your environment influences the type of WAPs you choose and where they will be installed. Is the wireless network for a commercial space, a school, a health care setting, or a manufacturing environment? How big is the building? What's the layout? If it's a commercial space, are the workers in an open, closed, or semi-enclosed space? What are the building materials inside the space? The signal in higher frequencies can be affected by concrete, security glass, and metal partition barriers. When you're planning for a Wi-Fi deployment, you need to ensure it will work in your setting.

At this point, you'll want to conduct a Radio Frequency (RF) survey to test for coverage, signal strength, and any possible interference. Based on the results of the RF survey, you can think about where you want to place the WAPs and how you will install them. Will it be a drop ceiling installation? A wall installation? Will you use a WAP enclosure? A combination of all three? Again, your environment comes into play here. For example, in a health care setting, WAPs should be enclosed, as infection control requirements place restrictions on removing or lifting ceilings.

## Industry Standards-based Design Recommendations

- TIA TSB-162-B: Newer Wi-Fi networks such as 802.11ac and 802.11ax rely on a square-cell layout. This standard calls for an 18.3-meter uniform cell design, with two cables per WAP. The WAP cord should be no more than 13 meters. The maximum length of the cable that connects the patch panel and equipment outlet should be no more than 80 meters — this cable will be your permanent link. The maximum length of the equipment cord from the Equipment Outlet (EO) to the WAP should be no more than 6 meters.

### TIA TSB-162-B

Based on a 60 ft x 60 ft Uniform Cell Size

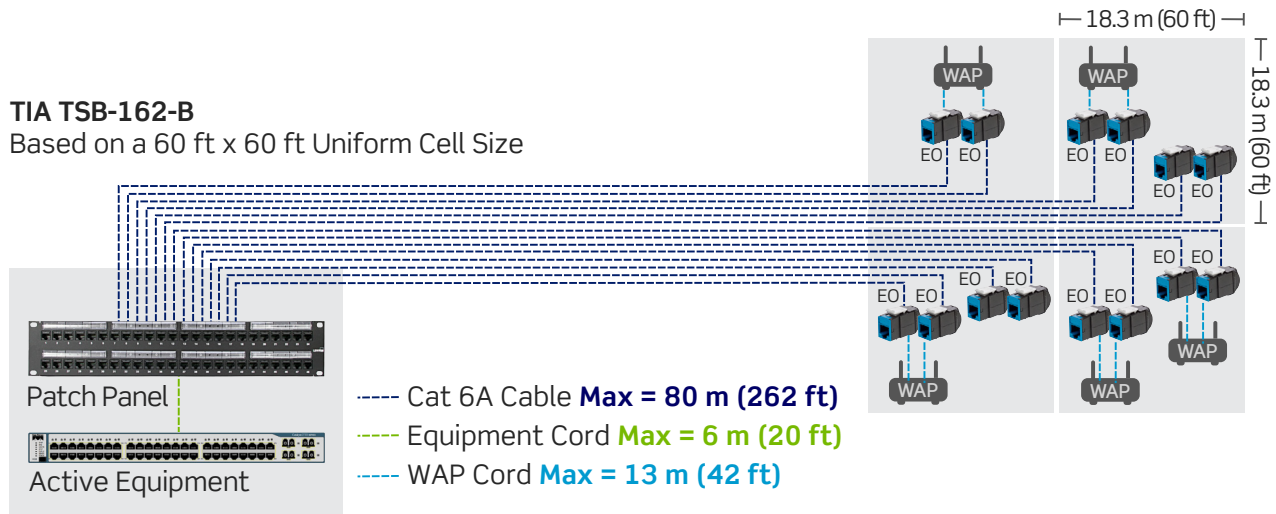

- TIA-4966: Schools and education facilities call for another type of installation. This recommendation is based on the number of people in the space. The telecommunications infrastructure recommends one WAP for every 25 people, or every 230 square meters. In settings that contain high RF interference, such as dorms, place one WAP for every 150 square meters.



## STEP 4: MAKE CABLING AND CONNECTIVITY CHOICES

To get the most out of the latest Wi-Fi technologies, the Telecommunications Industry Association (TIA) recommends using a minimum of two Cat 6A cables per WAP, which will give you higher data rates and increased power. The organization suggests you consider wiring at least two Cat 6A drops for every WAP to support up to the maximum theoretical speed of 10 Gb/s with 802.11ax and future upgrades. Also, Cat 6A is the cable you'll need to prepare for future generations of wireless networks.

### How to Get More Out of Your Cat 5e or Cat 6 Cable

What if you've recently installed Cat 5e or Cat 6 cabling, and your budget won't allow you to install Cat 6A? Because so many enterprise organizations have an existing Cat 5e or Cat 6 infrastructure, active-gear manufacturers have developed switches that support intermediate speeds of 2.5 and 5 Gb/s.

In place of upgrading your entire network infrastructure, you can upgrade the switch to support 2.5 and 5GBASE-T, and wireless access points to 802.11ax, which will allow system speeds of up to 5 Gb/s. This is a less expensive, temporary fix compared to upgrading all network cabling.

2.5GBASE-T and 5GBASE-T Ethernet products are new, and can function over existing Cat 5e or Cat 6 cabling — with some limitations on cable bundle size and channel length. This technology enables the upgrade of older Wi-Fi networks but will not provide the full benefit of the upgrade that Cat 6A cabling operating at 10Gbps enables.

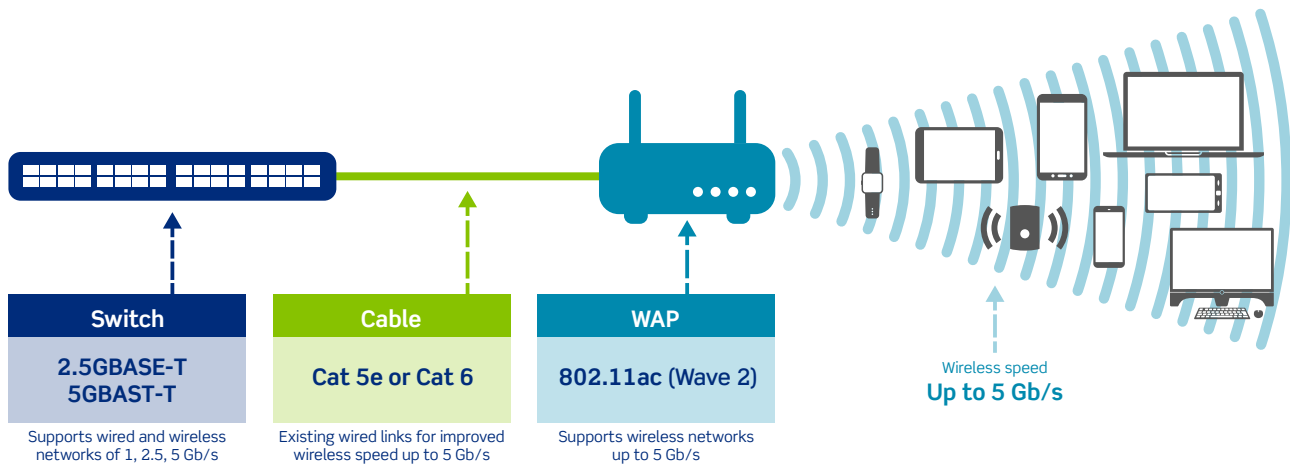

**If are looking at an upgrade to 2.5 and 5GBASE-T switches, consider the following points:**

- **Alien Crosstalk (AXT)** — When running higher data rates over existing Cat 5e or Cat 6 cable, AXT might be an issue, especially for longer channels with significant bundled cable lengths. AXT limits are not directly specified for 2.5GBASE-T or 5GBASE-T. However, Alien Limited Signal-to-Noise Ratio (ALSNR) — a new measurement based on AXT, attenuation, and other factors — was developed to assess a channel’s susceptibility to AXT, as well as its ability to support 2.5 Gb/s and 5 Gb/s speeds. Recent risk assessments of 2.5 and 5GBASE-T based on modeling, testing, and the ALSNR calculation find a medium to high risk of Cat 5e and Cat 6 infrastructures not meeting the ALSNR requirement at longer channel lengths. Generally, the longer the overall channel length and the more bundled length of cable in the channel, the greater the risk. Cat 6 poses less risk than Cat 5e; using either for 5 Gb/s poses more risk than 2.5 Gb/s.
- **Power over Ethernet (PoE)** — If you intend to upgrade to an 802.11ax WAP, which gives you faster speed but less coverage, you’ll likely need to install more WAPs. And those newer or higher WAPs will have more antennas, and require more power and more cable. Additional cable means larger cable bundles, which could generate too much heat — especially with Cat 5e or Cat 6 cabling. Consider these factors as you weigh the benefits of sticking with your existing network or upgrading to Cat 6A.
- **Future Needs** — In the near future, an enterprise wireless network that supports 5 Gb/s may not be big enough, depending on the application and environment. If you migrate to Cat 6A now, you’ll be ready for speeds up to 10 Gb/s through 802.11ax.

Leviton recommends upgrading to Cat 6A for new installations — as do industry standards — but if you do decide to go with an interim fix with 2.5 or 5GBASE-T, we suggest you conduct a thorough risk analysis before making a final decision. For more information, download a Leviton tech brief that covers the structured cabling considerations of 2.5 and 5GBASE-T.



For larger networks and those with lengths that are more than 50 meters, it might cost less to upgrade to Cat 6A cabling. The full upgrade is the best solution for enterprise businesses looking for system longevity, faster data transfer, and support for higher-bandwidth wireless networks.

### Solutions for the Latest Wireless Networks

Leviton Network Solutions is a leading provider of connectivity and cabling solutions for enterprise businesses. Our QuickPort® In-Ceiling solution — which includes plenum-rated cable, jacks, patch cords, surface-boxes, and brackets — provides a testable permanent link in drop ceilings to WAPs. It also allows the flexibility to move the In-Ceiling Bracket to refine Wi-Fi coverage or WAN placement without needing to retest the link.

Leviton's premier Category 6A system, featuring LM-SST cable, Atlas-X1® jacks, and patch cords, provides best-in-class performance, with enhanced Alien Crosstalk (AXT) protection for a clean wireless signal. And the system has been independently tested and guaranteed to exceed all Cat 6A component, permanent link, and channel margins.

The Atlas-X1 jacks are also ideal for WAPs that rely on Power over Ethernet. They have a PoE optimized tine geometry that prevents damage from electrical arcing at the critical contact mating zone between the plug and jack. And the jacks use patented Retention Force Technology to maintain contact force between the plug and jack, preventing intermittent disconnects that may cause arcing. Finally, Atlas-X1 UTP jacks have a solid metal body, which dissipates 53% more heat than plastic alternatives, reducing temperature build-up and the potential for heat-related performance issues.

If a Cat 6A upgrade does not meet your budget, Leviton Cat 5e and Cat 6 components can support 2.5 Gb/s and 5 Gb/s speeds within the guidelines and limitations of TSB-5021. Unfortunately, because of the inherent limitations of all Cat 5e and Cat 6 cabling, diversity of channel configurations, installation practices, and cabling environments, Leviton cannot offer warranties or guarantees of performance on 2.5GBASE-T and 5GBASE-T installations using Cat 5e or Cat 6 components.

Learn more about Leviton's cabling systems for wireless networks at [Leviton.com/wireless](https://www.leviton.com/wireless).

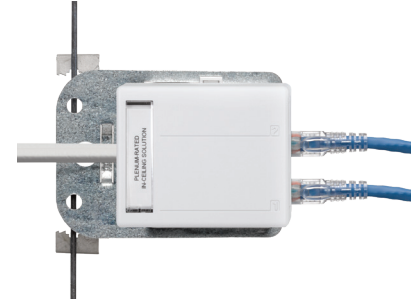

Today's networks must be fast and reliable, with the flexibility to handle ever-increasing data demands. Leviton can help expand your network possibilities and prepare you for the future. Our end-to-end cabling systems feature robust construction that reduces downtime, and performance that exceeds standards. We offer quick-ship make-to-order solutions from our US and UK factories. We even invent new products for customers when the product they need is not available. All of this adds up to the **highest return on infrastructure investment.**

#### USA — NETWORK SOLUTIONS HEADQUARTERS

2222 - 222nd Street S.E., Bothell, WA, 98021, USA  
+1 (800) 722 2082 | [infousa@leviton.com](mailto:infousa@leviton.com) | [leviton.com/ns](http://leviton.com/ns)

##### Customer Service

+1 (800) 722 2082  
[insidesales@leviton.com](mailto:insidesales@leviton.com)

##### International Customer Service

+1 (425) 486 2222  
[intl@leviton.com](mailto:intl@leviton.com)

##### Leviton Berk-Tek Cable Customer Service

+1 (800) 237 5835  
[berktek.info@leviton.com](mailto:berktek.info@leviton.com)

##### Technical Support

+1 (800) 722 2082  
+1 (425) 486 2222  
[appeng@leviton.com](mailto:appeng@leviton.com)

#### APAC

+85 (2) 3620 2602 | [infoapac@leviton.com](mailto:infoapac@leviton.com) | [leviton.com/ns](http://leviton.com/ns)

##### Customer Service

+1 (631) 812 6228  
[infoasean@leviton.com](mailto:infoasean@leviton.com)

##### China

+85 (2) 2774 9876  
[infochina@leviton.com](mailto:infochina@leviton.com)

##### South Korea

+82 (2) 3273 9963  
[infokorea@leviton.com](mailto:infokorea@leviton.com)

#### CANADA

+1 (800) 461 2002 | [infoCanada@leviton.com](mailto:infoCanada@leviton.com) | [leviton.com/ns](http://leviton.com/ns)

##### Customer Service

+1 (514) 954 1840  
[pcservice@leviton.com](mailto:pcservice@leviton.com)

Network Solutions products are **available worldwide** in over 100 countries. Visit us online at [leviton.com/ns](http://leviton.com/ns) to learn more.



#### EUROPE

Viewfield Industrial Estate, Glenrothes, KY6 2RS, UK  
+44 (0) 1592 772124 | [infoeurope@leviton.com](mailto:infoeurope@leviton.com) | [leviton.com/ns/emea](http://leviton.com/ns/emea)

##### Customer Service

+44 (0) 1592 772124  
[customerserviceeu@leviton.com](mailto:customerserviceeu@leviton.com)

##### Technical Support

+44 (0) 1592 778494  
[appeng.eu@leviton.com](mailto:appeng.eu@leviton.com)

##### Benelux

+44 (0) 1592 772124  
[infobenelux@leviton.com](mailto:infobenelux@leviton.com)

##### Nordics

+46 (70) 9675033  
[infonordics@leviton.com](mailto:infonordics@leviton.com)

##### Central & Eastern Europe (CEE)

+44 (0) 1592 772124  
[infocee@leviton.com](mailto:infocee@leviton.com)

##### Portugal

+351 (21) 421 4133  
[infoportugal@leviton.com](mailto:infoportugal@leviton.com)

##### DACH

+49 (0) 173 272 0128  
[infodach@leviton.com](mailto:infodach@leviton.com)

##### Spain

+34 (91) 490 59 19  
[infospain@leviton.com](mailto:infospain@leviton.com)

##### France

+33 (0) 1709 87826  
[infofrance@leviton.com](mailto:infofrance@leviton.com)

##### UK & Ireland

+44 (0) 1592 772124  
[infouk@leviton.com](mailto:infouk@leviton.com)

##### Italy

+39 (02) 3534896 (Milan)  
+39 (06) 68584613 (Rome)  
[infoitaly@leviton.com](mailto:infoitaly@leviton.com)

#### LATAM

[infoLatam@leviton.com](mailto:infoLatam@leviton.com) | [leviton.com/ns](http://leviton.com/ns)

##### Customer Service

+52 (55) 2333 5963  
[infoLatam@leviton.com](mailto:infoLatam@leviton.com)

##### Caribbean

+1 (954) 593 1896  
[infoCaribbean@leviton.com](mailto:infoCaribbean@leviton.com)

##### Mexico

+52 (55) 2128 6286  
[lsamarketing@leviton.com](mailto:lsamarketing@leviton.com)

##### Colombia

+57 (1) 743 6045  
[infoColombia@leviton.com](mailto:infoColombia@leviton.com)

#### MIDDLE EAST & AFRICA

Bay Square, Building 3, Office 205, Business Bay, Dubai, UAE  
+971 (4) 247 9800 | [infoMEA@leviton.com](mailto:infoMEA@leviton.com) | [leviton.com/ns](http://leviton.com/ns)

##### Customer Service

+971 (4) 247 9800  
[lmefinfo@leviton.com](mailto:lmefinfo@leviton.com)