

Multi-Bay Attachment Tube

APPLICATION

The Multi-Bay Attachment Tube joins two or more Leviton Wireless STRUCTURED MEDIA™ Center Enclosures to create a multi-bay enclosure system. It provides flexibility to accommodate installations that have more components than a single enclosure can hold, or applications where there is a need to separate provider and customer equipment.



SPECIFICATION

Multi-Bay Attachment Tube shall be molded from white flame-retardant ABS, rated UL 94 V-0. Tube shall install into two-inch knockouts of Leviton Wireless STRUCTURED MEDIA™ Centers, allowing two such enclosures to be joined. Tube shall allow for easy passthrough of communications cabling.

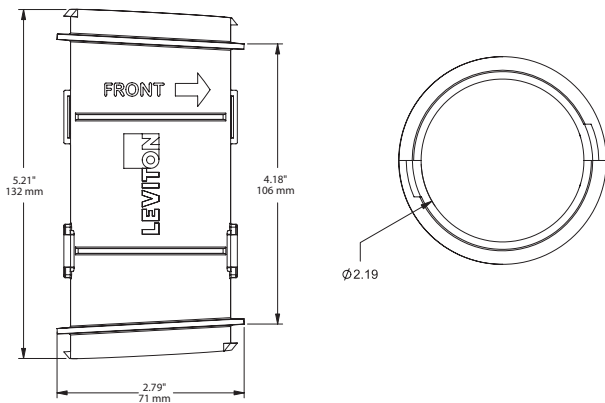

FEATURES & BENEFITS

- Installs easily using integrated arrows for direction
- Installs in two-inch knockouts at top or bottom of any size Wireless STRUCTURED MEDIA™ Center

DESIGN CONSIDERATIONS

- Allows for passthrough of cables

STANDARDS & REGULATIONS

- RoHS
- c(UL)us Listed, UL 2416

MECHANICAL SPECIFICATIONS

Dimensions: See below
Materials: ABS plastic, white, UL 94 V-0

COUNTRY OF ORIGIN

USA

WARRANTY INFORMATION

For Leviton product warranties, go to Leviton.com/ns/warranty

Two 14" Wireless Structured MEDIA CENTERS™ joined by the Multi-Bay Attachment Tube

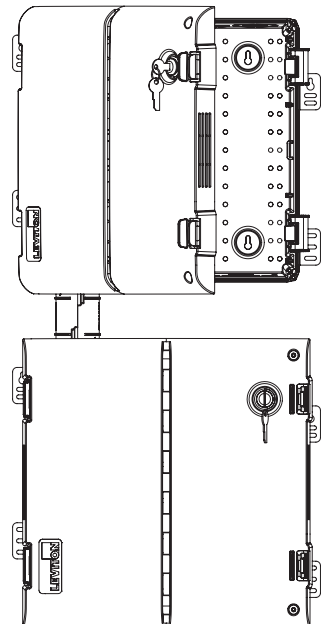

PART NUMBER	
Description	Part No.
Multi-Bay Attachment Tube for Wireless STRUCTURED MEDIA™ Centers	49605-TUB

For further support information, visit Leviton.com/NS/Support

Page 1 of 1

USA
Network Solutions Headquarters
+1 (800) 722 2082
infoUSA@leviton.com

BERK-TEK™ Cable
+1 (800) 237 5835 | infoUSA@leviton.com

Asia Pacific
+852 3620 2602
infoAPAC@leviton.com

Canada
+1 (800) 461 2002
infoCanada@leviton.com

Europe
+44 (0) 1592 772124
infoEurope@leviton.com

Latin America
MX: +52 (55) 2128 6286
LATAM: +52 (55) 2333 5963
infoLATAM@leviton.com

Middle East & Africa
+971 (4) 247 9800
infoMEA@leviton.com

NETWORK SOLUTIONS PRODUCTS ARE AVAILABLE WORLDWIDE IN OVER 100 COUNTRIES. VISIT US ONLINE AT LEVITON.COM/NS TO LEARN MORE.