

Front Loading UTP QUICKPORT™ Patch Panel

APPLICATION

Front Loading UTP QUICKPORT Patch Panels are compatible with all QUICKPORT connectors to maximize versatility with a variety of media applications and enable easy upgrades. The panel fits all industry-standard 19-inch racks and cabinets, and supports jack loading from the front or rear of the panel; ideal when rear panel access is limited.



Patch Panel



Bezel (not to scale)

SPECIFICATION

Front Loading Patch Panel shall be comprised of a metal panel with a black powder coat finish with silk screen port numbers above each port. The panel shall be offered in a 48-port 2RU configuration. The panel shall include 48 high-impact thermoplastic front-loading bezels made from UL 94V0 rated material. Bezels shall accept all Leviton QUICKPORT connectors. Bezels shall be individually removable from the patch panel allowing single port installation or replacement from the panel front. When installed in the panel, bezels allow for rear jack installation without bezel removal. The panel provided two mounting positions for a rear cable management bar. A single rear mounting bar shall be included with the panel. Panel shall be ANSI/TIA-568 compliant and c(UL)us Listed.

FEATURES & BENEFITS

- Mounts on 19-inch equipment racks
- 2 rack unit 48-port panel
- Supports jack installation from the front or rear; ideal for hard to access applications
- Vertical port numbers mimic switch numbering
- Includes one tool-free mounting rear cable management bar and supports an optional second bar (sold separately, 49005-CMB)
- Accepts all QUICKPORT-style connectors (sold separately)
- Boxed and packaged in Sustainably Smart Packaging

STANDARDS & REGULATIONS

- ANSI/TIA-568
- c(UL)us Listed

MECHANICAL SPECIFICATIONS

Dimensions:	See page two
Materials:	18-gauge steel; high-impact, fire-retardant plastic
Capacity:	48-port
Mounting:	19-inch rack mount
Color:	Black
Temp.(Storage):	-40 °C to +70 °C (-40 °F to +158 °F)
Temp.(Operating):	-10 °C to +60 °C (+14 °F to +140 °F)
Humidity (Max.):	95% relative humidity, non-condensing

COUNTRY OF ORIGIN

China

WARRANTY INFORMATION

For Leviton product warranties, go to [Leviton.com/ns/warranty](https://www.leviton.com/ns/warranty)

49455-48B, FLPBE-4EB

PRODUCT SPECIFICATIONS
49455-48B, FLPBE-4EB

49455-48B, FLPBE-4EB

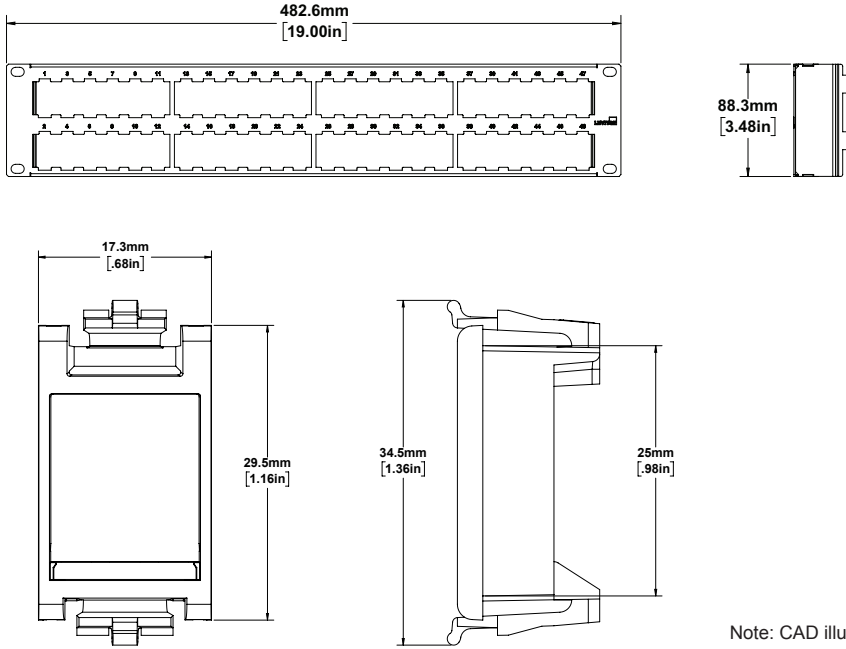

Note: CAD illustrations are not to scale

PART NUMBER

Description	Part No.
Front Loading UTP QUICKPORT™ Patch Panel with vertical numbering, 2RU, 48-port, black	49455-48B
4-Pack Front-Loading Panel Bezel Replacements	FLPBE-4EB

For further support information, visit Leviton.com/ns/support