



Commercial Dimmer Pack Installation & Operation Guide

2408CD - DIMMER PACK

2408CR - RELAY PACK

Leviton Energy Management, Controls, and Automation
20497 SW Teton Avenue, Tualatin, OR 97062
Customer Service Telephone: 1-800-736-6682 • FAX: 1-503-404-5600
Tech Line: 1-800-824-3005

Leviton Manufacturing Co., Inc.
201 North Service Road, Melville, N.Y. 11747
Telephone: 1-800-323-8920 • FAX: 1-800-832-9538

Visit Leviton's Web site at <http://www.leviton.com>
© 2016 Leviton Manufacturing Co., Inc. All Rights Reserved

Specifications and Price Subject to Change at any time without notice

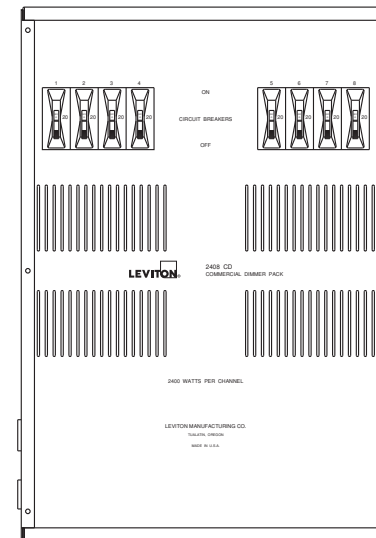

WEB VERSION

INSTALLATION

MOUNTING

The 2408 CD Dimmer pack or 2408 CR Relay pack must be mounted securely in a dry location to the surface of a wall or other vertical flat surface in a manner which is capable of supporting its weight. Nine "key-hole" type mounting holes for 1/4" lag screws are provided in the back wall of the unit for this purpose (**figure 1**).

Since the 2408 CD/CR depends upon convection cooling, room airflow must not be prevented by walls or other obstructions. Adequate side and top clearances from adjacent walls and equipment are necessary:

Minimum distance from top to ceiling:	36"
Minimum distance from top to other equipment:	12"
Minimum distance from side adjacent to wall:	12"
Minimum distance from side to other equipment:	6"

If several units are to be installed in a small-enclosed room, adequate ventilation must be provided to prevent the room temperature from exceeding 100 degrees Fahrenheit.

Clear working space and access to the 2408 CD/CR **must be** provided in accordance with electrical codes.

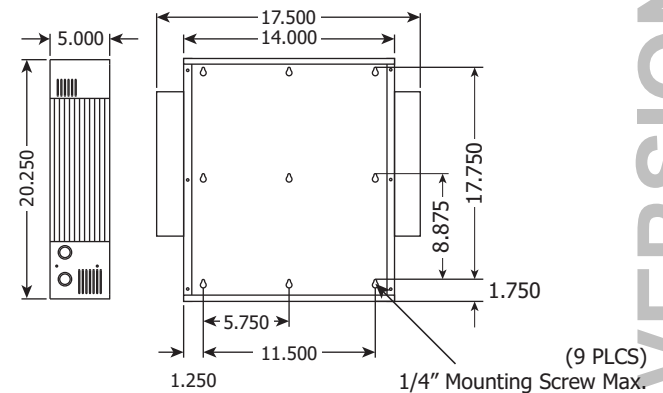

Figure 1
MOUNTING

INPUT WIRING

The 2408 CD/CR must be provided with an 80 amp, 120/240 or 120/208Y VAC, three wire electrical service. This service must include two live wires not exceeding 150 volts to ground and one neutral wire. In addition the unit must be grounded by conduit or an additional ground wire in accordance with electrical codes.

The input wiring should be #4 AWG THWN or equivalent copper wire rated for least 75 C.

Pass the input wiring through the 1 1/4" conduit hole in the top of the unit. Allow the wires to drop 4-6" into the unit then loop the wires back upwards. Connect each of the two live wires to the copper lugs located above the circuit breakers and connect the neutral wire to the neutral bar. If provided, connect the additional ground wire to the terminal marked "GND".

120/240 or 120/200 80A

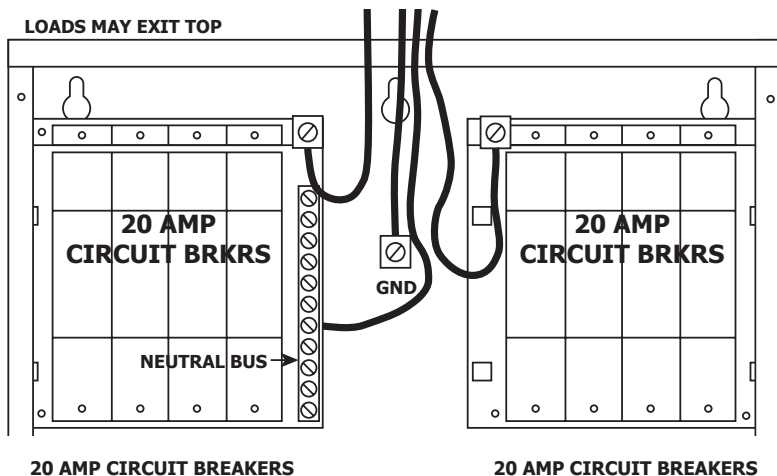

Figure 2
INPUT WIRING

LIMITED 2 YEAR WARRANTY AND EXCLUSIONS

Leviton warrants to the original consumer purchaser and not for the benefit of anyone else that this product at the time of its sale by Leviton is free of defects in materials and workmanship under normal and proper use for two years from the purchase date. Leviton's only obligation is to correct such defects by repair or replacement, at its option. **For details visit www.leviton.com or call 1-800-824-3005.** This warranty excludes and there is disclaimed liability for labor for removal of this product or reinstallation. This warranty is void if this product is installed improperly or in an improper environment, overloaded, misused, opened, abused, or altered in any manner, or is not used under normal operating conditions or not in accordance with any labels or instructions. **There are no other or implied warranties of any kind, including merchantability and fitness for a particular purpose,** but if any implied warranty is required by the applicable jurisdiction, the duration of any such implied warranty, including merchantability and fitness for a particular purpose, is limited to two years. **Leviton is not liable for incidental, indirect, special, or consequential damages, including without limitation, damage to, or loss of use of, any equipment, lost sales or profits or delay or failure to perform this warranty obligation.** The remedies provided herein are the exclusive remedies under this warranty, whether based on contract, tort or otherwise.

TRADEMARK DISCLAIMER

Use herein of third party trademarks, service marks, trade names, brand names and/or product names are for informational purposes only, are/may be the trademarks of their respective owners; such use is not meant to imply affiliation, sponsorship, or endorsement.

FOR CANADA ONLY

For warranty information and/or product returns, residents of Canada should contact Leviton in writing at **Leviton Manufacturing of Canada Ltd to the attention of the Quality Assurance Department, 165 Hymus Blvd, Pointe-Claire (Quebec), Canada H9R 1E9** or by telephone at **1 800 405-5320.**

LOAD WIRING

The 2408 CD/CR can provide eight tungsten or resistive branch lighting circuits of 120V AC at 20 amps each. If the lighting loads are expected to operate continuously at full power for three hours or more, then the load must not exceed 16 amps in accordance with electrical codes.

The load wiring should be at least #12 AWG in size and must be copper wire rated for at least 75 C such as THWN .The load wiring may exit through either of the 1/2"- 3/4" knockouts located in the load wiring compartment or may exit through the top of the unit.

2408 CD

The live wire (black) of each load connects to the copper terminal located below each filter coil. The neutral wires (white) for all loads connect to the neutral bar located near the circuit breakers. If the loads require individual ground wires, these will connect to the ground bar located in the load-wiring compartment.

2408 CR

The live wire (black) of each load connects directly to the 1/4" quick-connect tabs of the solid state power cubes using the yellow crimp-on connectors provided. The channel number corresponding to the power cube tab is indicated on the cube. The neutral wires (white) for all loads connect to the neutral bar located near the circuit breakers. If the loads require individual ground wires, these will connect to the ground bar located in the load-wiring compartment.

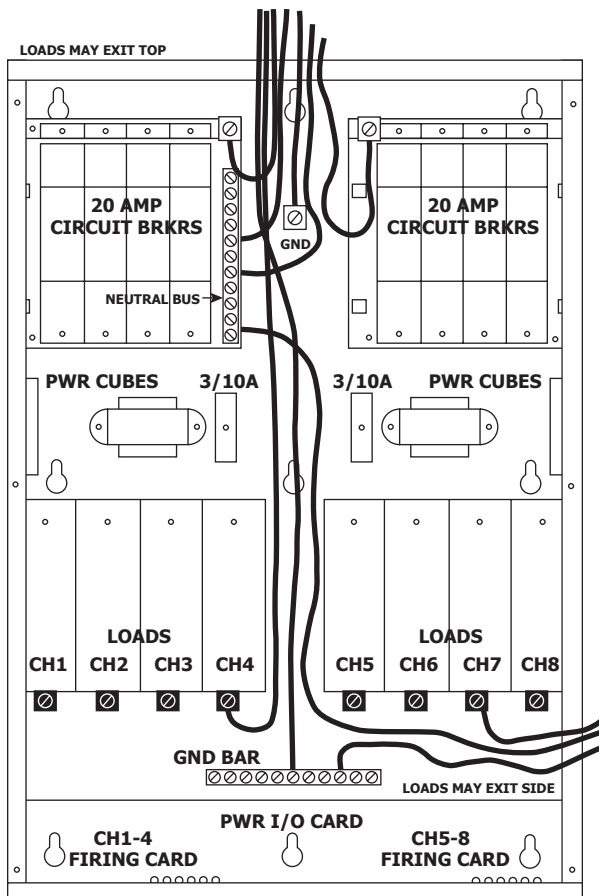

Figure 3
LOAD WIRING

INSTALLATION TIPS

Care should always be taken to:

- 1) Keep all AC wiring away from control wiring.
- 2) Perform a careful inspection of control circuitry for wire clippings and verification of connections.
- 3) We also recommend powering up and performance checks be done one unit at a time. This can be a real time saver should problems arise thus eliminating unnecessary isolation techniques to resolve said problem.

OPERATION

To raise lighting levels with a 400CP remote:

Press and hold the increase button of the zone desired. If the unit is in the power down state, power will come on in 1/4 second. The 400CP will then take control of all dimmer channels assigned to the selected zone and increase lighting levels at the programmed fade rate. Release button when correct lighting levels are attained.

To lower lighting levels with a 400CP remote:

Press and hold the decrease button of the zone desired. If the unit is in the power down state, power will come on in 1/4 second. The 400CP will then take control of all dimmer channels assigned to the selected zone and decrease lighting levels at the programmed fade rate. Release button when correct lighting levels are attained.

To take control with a console using DMX, AMX, Microplex, or Analog control system:

Simply perform a change in the channel level from the console. The lighting channel will then fade back to the new console level at a moderate fade rate. Once the lighting level matches the console level, full console control will be resumed.

265-268	0100001	269-272	1100001	273-276	0010001
277-280	1010001	281-284	0110001	285-288	1110001
289-292	0001001	293-296	1001001	297-300	0101001
301-304	1101001	305-308	0011001	309-312	1011001
313-316	0111001	317-320	1111001	321-324	0000101
325-328	1000101	329-332	0100101	333-336	1100101
337-340	0010101	341-344	1010101	345-348	0110101
349-352	1110101	353-356	0001101	357-360	1001101
361-364	0101101	365-368	1101101	369-372	0011101
373-376	1011101	377-380	0111101	381-384	1111101
385-388	0000011	389-392	1000011	393-396	0100011
397-400	1100011	401-404	0010011	405-408	1010011
409-412	0110011	413-416	1110011	417-420	0001011
421-424	1001011	425-428	0101011	429-432	1101011
433-436	0011011	437-440	1011011	441-444	0111011
445-448	1111011	449-452	0000111	453-456	1000111
457-460	0100111	461-464	1100111	465-468	0010111
469-472	1010111	473-476	0110111	477-480	1110111
481-484	0001111	485-488	1001111	489-492	0101111
493-496	1101111	497-500	0011111	501-504	1011111
505-508	0111111	509-512	1111111		

TESTING

If desired, the dimmer may be tested without any control signal input by moving SWITCH #8 to the off and then the on position on both of the dimmer firing cards after the system is energized. This will cause all dimmer channels to go to full intensity for testing load circuits. Dimmers will ignore all control signals in this case.

NOTE:

If Switch #8 is set on before power is applied to the dimmers, then the lighting loads associated with that firing card will come to 50% intensity (full on for CR's) when power comes on. This is useful for emergency lighting purposes. The console or remote panels may take control after light come on.

CAUTION

INSPECT INSIDE OF DIMMER PACK FOR LOOSE BITS OF WIRE OR HARDWARE THAT MAY HAVE FALLEN ONTO THE CONTROL CIRCUIT BOARDS AND BE SURE ALL INPUT AND LOAD WIRING IS COMPLETE BEFORE ENERGIZING ELECTRICAL SERVICE TO DIMMER.

CONTROL WIRING

Control wiring to the 2408CD should be Class 2 wiring. All control wiring must stay below the barrier separating the control wiring compartment from the load wiring. All control wiring must exit out of either of the 1/2"-3/4" knockouts located in the control wiring compartment. Several types of low voltage control inputs may be employed as discussed below. Under no circumstances can any control signal input exceed 15 volts.

Individual 0-10 VDC control wiring

Each of the eight dimmer channels of the 2408 CD/CR may be operated by a 0-10 VDC control voltage. This type of control will provide 0% intensity at 0 volts and 100% intensity at 10 volts. Any or all of the dimmer channels may be operated in this manner simultaneously with either of the multiplex control inputs. Each dimmer will respond to the greater of any control inputs.

Connect each of the plus control wires to the desired dimmer channel connections (**see figure 3**) on each of the dimmer firing cards. Connect the common control wire to one of the COMMON connections provided on the power supply card. This control input impedance is 4.7K ohms.

If a +15 VDC power source is required for the control console, connect an additional wire to the + 15 VDC terminal on the power supply board. This wire and the common wire must be at least 18 gauge. This power supply can deliver 750 MA maximum and can be connected in parallel to other 2408 CD/CR packs.

DMX-512 multiple control wiring

DMX-512 is the preferred type of control wiring because of the high update rate and the resistance to interference. It is highly recommended in locations subject to electrical noise. DMX-512 only requires 3 wires transmit lighting levels to as many as 512 dimmer channels. DMX-512 should not be used simultaneously with Microplex. Most of the Leviton lighting control consoles can use this interface.

Connect the three DMX-512 control wires to the appropriate terminals provided on the power supply card. Duplicate terminals are provided to carry the control connections to more dimmer packs if necessary. Be sure to set the Channel Address on the dipswitches of the dimmer firing cards as required. If a+ 15 VDC power source is required for the control console, connect an additional wire to the + 15 VDC terminal on the power supply board. This wire and the common wire must be at least 18 gauge. This power supply can deliver 750 MA maximum and can be connected in parallel to other 2408 CD/CR packs.

Microplex multiplex control wiring

Microplex is the control protocol used on all Leviton lighting console. This system uses a shielded wire to transmit up to 128 channels of dimmer control. Microplex should not be used simultaneously with DMX-512. For short distances (50 feet) a standard microphone cable is used to carry both the control signal and the DC power source for Leviton control consoles. Longer distances may be accommodated with 18 gauge or better cable to reduce voltage losses of the power supply.

Connect the Microplex control wires to the appropriate terminals on the power supply card. If an XLR type connector is used to connect the control console, connect pin 1 to common, pin 2 to + 15 VDC, and pin 3 to MICROPLEX. A duplicate set of connections is provided to carry the control signal to more dimmer packs. Be sure to set the Channel Address dip switch as required.

SWITCH SETTINGS

When using any of the multiplex control systems the dip switches on the 2408 CD/CR must be set to assign the desired dimmer channels. The switches control the dimmer channels in groups of four. The dip switch on the left dimmer firing card controls circuit channels 1-4 while the dip switch on the right card controls circuit channels 5-8 of the pack. Both switches may be set to the same settings if only four control channels are desired. See the following chart for settings.

DIPSWITCH CHANNEL ASSIGNMENTS

CONTROL	1234567	CONTROL	1234567	CONTROL	1234567
1-4	0000000	5-8	1000000	9-12	0100000
13-16	1100000	17-20	0010000	1-24	1010000
25-28	0110000	29-32	1110000	33-36	0001000
37-40	1001000	41-44	0101000	45-48	1101000
49-52	0011000	53-56	1011000	57-60	0111000
61-64	1111000	65-68	0000100	69-72	1000100
73-76	0100100	77-80	1100100	81-84	0010100
85-88	1010100	89-92	0110100	93-96	1110100
97-100	0001100	101-104	1001100	105-108	0101100
109-112	1101100	113-116	0011100	117-120	1011100
121-124	0111100	125-128	1111100	129-132	0000010
133-136	1000010	137-140	0100010	141-144	1100010
145-148	0010010	149-152	1010010	153-156	0110010
157-160	1110010	161-164	0001010	165-168	1001010
169-172	0101010	173-176	1101010	177-180	0011010
181-184	1011010	185-188	0111010	189-192	1111010
193-196	0000110	197-200	1000110	201-204	0100110
205-208	1100110	209-212	0010110	213-216	1010110
217-220	0110110	221-224	1110110	225-228	0001110
229-232	1001110	233-236	0101110	237-240	1101110
241-244	0011110	245-248	1011110	249-252	0111110
253-256	1111110	257-260	0000001	261-264	1000001

For house lighting and architectural systems

Make sure the jumper block on each control card is installed across both jumper pins marked SPCL on the. It is also a good idea to make sure the jumper is installed across both jumper pins marked SOFTSTART (CD's only).

For Stage Lighting Systems

Make sure the jumper block on each control card is NOT across both jumper pins marked SPCL. You must also remove the SOFTSTART jumper on each control card so the lights will not appear sluggish in response.

NON-DIM CHANNELS

Any of the channels of the 2408 CD can be configured as NON-DIM channels. This will cause the output of the channel to go to full on whenever the input signal is over 10. When to input signal drops to less than 100C; the channel output goes to full off. This is the equivalent of a zero-crossing solid state relay.

To configure a channel for NON DIM operation simply remove the jumper block from the pins on the firing card as indicated. Replacing the jumper block will restore dimming operation.

CHANNEL	JUMPER BLOCK	FIRING CARD
1	J8	1-4
2	J9	1-4
3	J10	1-4
4	J11	1-4
5	J8	5-8
6	J39	5-8
7	J10	5-8
8	J11	5-8

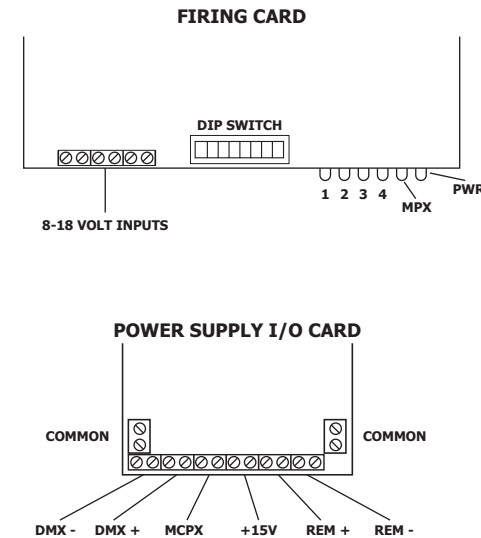

**Figure 4
CONTROL WIRING**

Remote control connections

Special accessories manufactured by Leviton may be connected to this dimmer, such as the 400CP control panel for doorways. See the installation instructions that come with these accessories.

LED'S

The indicator LED's on the dimmer firing cards indicate the status of the dimmer.

- **RED:** Indicates the card is receiving DC power (both cards will light even if only one line is energized).
- **GREEN:** Steady indicates a multiplex control signal is being received. Flashing indicates that a fade, initiated from a remote panel, is in process.
- **YELLOW:** Indicates a respective dimmer channel is active and LED indicates relative intensity.

JUMPER SETTINGS

NON-VOLATILE MEMORY

The version C control card now contains an EEPROM device to store lighting levels for automatic full restoration after a power fail.

When the installer enables this feature, the dimmer will save the current lighting levels in non-volatile memory 10 minutes after there has been a change in lighting levels. This is an important feature in house and architectural lighting systems, where it is important for the lighting to be fully restored after a power blackout. Dip Switch 8 may be left on in lieu of the memory jumper for restoration to a fixed level of 50% instead.

In theatrical stage lighting systems, this feature may not be desirable, since the dimming system is turned off frequently

SOFTSTART

The 2408 CD comes from the factory configured in the "SOFTSTART" operating mode. This mode of operation forces at least a 1/10th second delay between the output being full off to the output being full on to allow a more gradual warming of the lamp filaments. Thermal shock and inrush currents are reduced thereby increasing lamp life and preventing nuisance tripping of the circuit breakers.

To disable SOFTSTART; remove the jumper block from the pins marked 112 on the firing cards. Each firing card affects only it's respective four channels. Replacing the jumper block will restore SOFTSTART.

NOTE:

The 2408 CR and any channels of the 2408 CD configured for NON DIM operation will not be affected by SOFTSTART.