

VerifEye™ Potted Mini Meters

Submetering Solutions for Accurate Measurement & Verification



- kWh Meter
- 1 Phase 2W 120V
- 1 Phase 3W 120/240V (Split Phase)
- 100-200 Amps
- Pulse Output - standard feature
- With 0.1 kWh and 1 kWh mechanical counter resolution

DESCRIPTION

The VerifEye™ Potted Mini Meter line of revenue grade meters come with permanently attached, highly accurate Solid Core Current Transformers (CTs) for revenue-grade performance certified to ANSI standards. The Potted Mini Meters meet all measurement and verification-based opportunities including load management and LEED rating achievement. Designed to provide a simple and effective process for accurately capturing measurements of power consumption, Potted Mini Meters are easy to specify and install for new construction and retrofits.

- 1 or 2 CT applications
- Revenue grade accuracy
- Compact footprint; fits almost anywhere
- Cost effective solution
- Isolated pulse output channel for AMR compatibility
- True OEM solution
- Multi-tenant residential applications
- Marina applications
- Mobile home parks
- Campgrounds

Competing products use current sensors that do not provide the same level of performance.

Every Potted Mini Meter has an installer-friendly feedback feature. The red reverse phase indicator acts as an installation diagnostics tool and illuminates if a meter is improperly installed. After installation, the green duty cycle light shows that the meter is collecting electric consumption data at the appropriate rate.

All 100 and 200 Amp solid core CTs have color-coded labels to easily identify and correctly associate them with the appropriate phase in the panel. The Potted Mini Meters are approved by the California Division of Measurement Standards.

PRODUCT DATA

APPLICATIONS

Use Potted Mini Meters in multi-tenant residential and specific commercial industrial applications for:

- Load profiling and benchmarking
- AMR/BAS/BMS/EMS integration
- Usage aggregation
- Tenant cost allocation
- Measurement and verification
- Energy conservation and cost reduction
- Green building initiatives and government mandates

CONFIGURATIONS

AMPERAGES	PHASE/VOLTAGES
100 and 200A	1P/2W - 120V
100 and 200A	1P/3W -120/240V Split Phase

* Contact factory for non-US voltage configurations.

FEATURES

- Measures kWh
- Revenue grade: conforms to all applicable standards of ANSI C12.1
- Equipped standard with an Isolated Pulse Output channel for automated meter reading
- Utilizes revenue grade 0.3% accuracy class 0.1A secondary solid core current transformers (CTs) that conform to all applicable ANSI requirements
- Five year warranty

DIMENSIONS

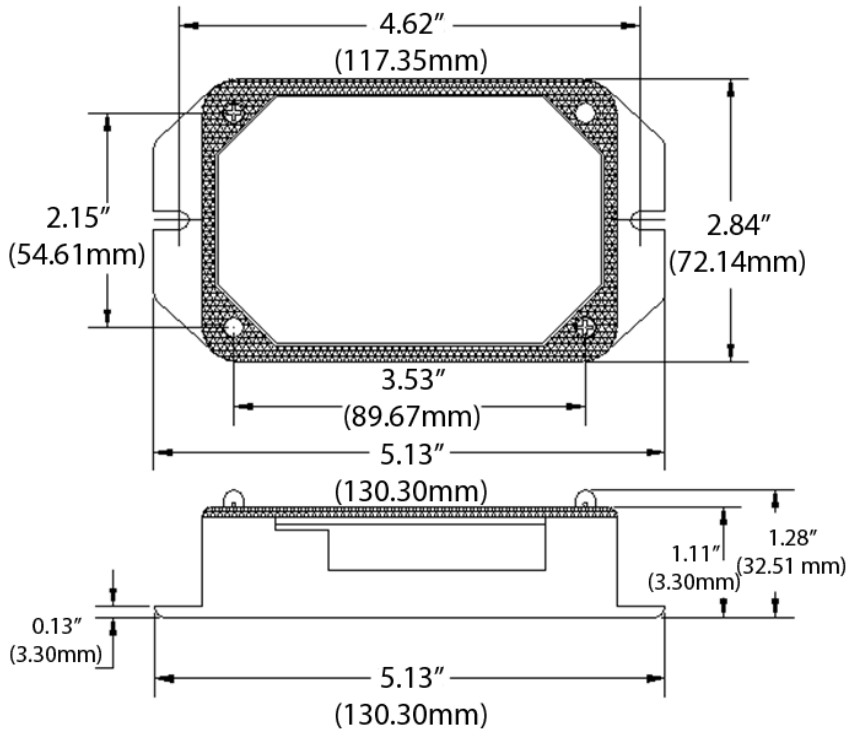

SINGLE ELEMENT- POTTED MINI METER HOOKUP DIAGRAM

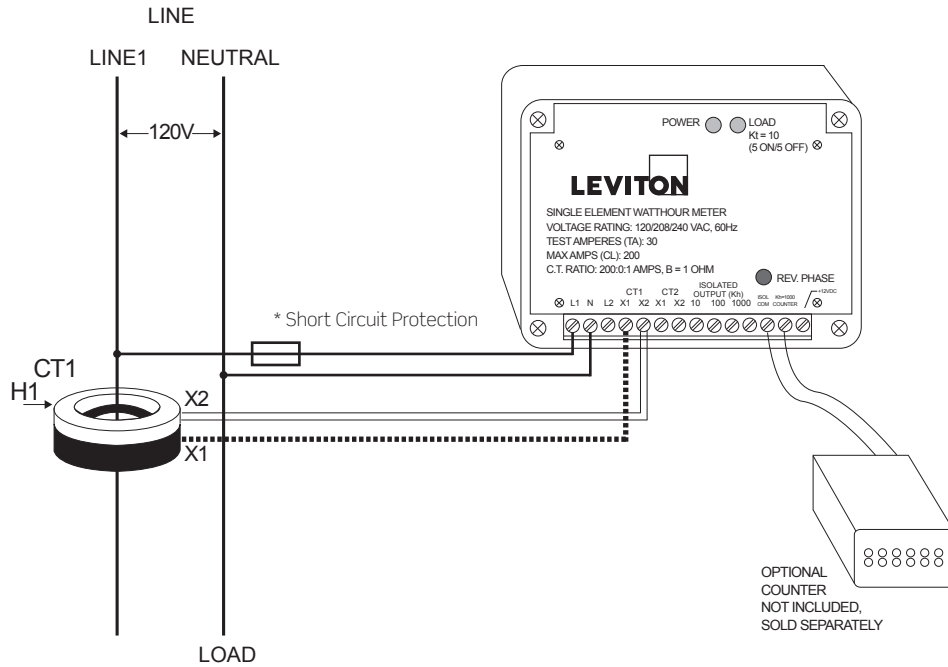

DUAL ELEMENT - POTTED MINI METER HOOKUP DIAGRAM

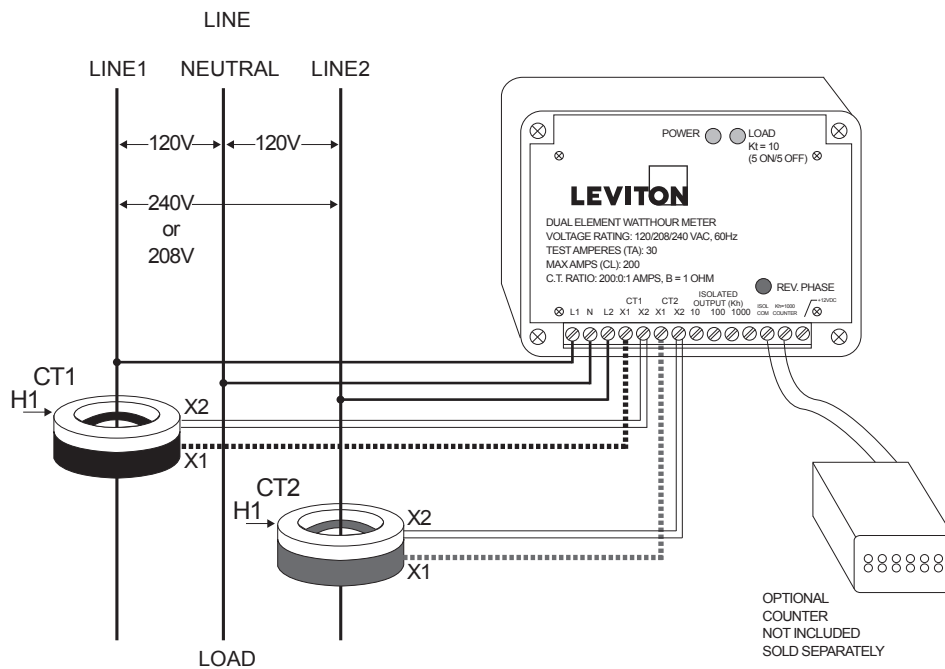

Leviton provides solid core CTs to achieve revenue grade accuracy. Our 100A and 200A color coded CTs assist with correct installation by indicating phase monitored.

*Short circuit protection per NEC and local codes by others

Leviton Manufacturing Co., Inc. Energy Management, Controls and Automation

20497 SW Teton Avenue, Tualatin, OR 97062 tech line 800-959-6004 fax 503-404-5594

©2016 Leviton Manufacturing Co., Inc. All rights reserved. Subject to change without notice.

PRODUCT DATA



ORDERING INFORMATION

VOLTAGE	CTs INCLUDED	DESCRIPTION	CAT. NO.
120V 1PH 2W	Solid Core	Single Element 100A Potted Mini Meter, 1 kWh resolution, mechanical counter not included, sold separately	5B101-H01
120V 1PH 2W	Solid Core	Single Element 200A Potted Mini Meter, 1 kWh resolution, mechanical counter not included, sold separately	5B101-H02
120V 1PH 2W	Solid Core	Single Element 100A Potted Mini Meter, 0.1 kWh resolution, mechanical counter not included, sold separately	5B101-T01
120V 1PH 2W	Solid Core	Single Element 200A Potted Mini Meter, 0.1kWh resolution, mechanical counter not included, sold separately	5B101-T02
120/240V 2PH 3W	Solid Core	Dual Element 100A Potted Mini Meter, 1 kWh resolution, mechanical counter not included, sold separately	5B201-H01
120/240V 2PH 3W	Solid Core	Dual Element 200A Potted Mini Meter, 1 kWh resolution, mechanical counter not included, sold separately	5B201-H02
120/240V 2PH 3W	Solid Core	Dual Element 100A Potted Mini Meter, 0.1 kWh resolution, mechanical counter not included, sold separately	5B201-T01
120/240V 2PH 3W	Solid Core	Dual Element 200A Potted Mini Meter, 0.1 kWh resolution, mechanical counter not included, sold separately	5B201-T02
MECHANICAL COUNTER			
CAT. NO	DESCRIPTION		
MPCTR-1KW	Mechanical Counter, 12VDC, Kubler, 1 kWh		
MPCTR-MPL	Mtg Plate for Kubler Mechanical Counter		
MPCTR-TKW	Mechanical Counter, 12VDC, Kubler, 1/10 kWh		

The following products are also part of the Leviton VerifEye line of submetering solutions:

- Series 1000 Meters
- Series 2000 Meters
- Series 3500 Meters
- Series 4000/4100 Meters
- Series 8000 Multi-Point Meters
- EMH+ Integrated Meter & Hub
- 0.5% Mini Meters
- Mini Meters
- Multiple Meter Units (MMUs)
- Current Transformers (CTs)
- BillSuite
- Energy Management Monitoring Software
- Building Manager Online (BMO) 3.0

VerifEye™ Potted Mini Meters

Leviton Manufacturing Co., Inc. Energy Management, Controls and Automation

20497 SW Teton Avenue, Tualatin, OR 97062 **tel** 800-736-6682 **fax** 503-404-5594 **tech line** (6:00AM-4:00PM PT Mon-Fri) 800-959-6004

Leviton Manufacturing Co., Inc. Global Headquarters

201 North Service Road, Melville, NY 11747-3138 **tel** 800-323-8920 **fax** 800-832-9538 **tech line** (8:30AM-7:00PM ET Mon-Fri) 800-824-3005

Visit our Website at: www.leviton.com/verifeye

©2016 Leviton Manufacturing Co., Inc. All rights reserved. Subject to change without notice.

G-9337A/16-aa
REV SEP 2016