

Multi-Technology Ceiling Occupancy Sensor with Isolated Relay



BASIC OPERATION

Occupancy sensors have two tasks: 1) Keeping the lights ON while the room is occupied, and 2) Saving energy by keeping the lights OFF while the room is unoccupied.

The Leviton OSCxx-RMW sensors combine the benefits of both Passive Infrared (PIR) and Ultrasonic (U/S) technologies for unrivaled performance and reliability. Additionally, the sensor is designed with an isolated relay contact; which enables the sensor to interface with other systems (example: BAS, HVAC or any dry-contact capable device or system).

APPLICATIONS

- Cafeterias
- Computer rooms
- Day care centers
- Workspaces
- Restrooms
- Offices with cubicles
- Classrooms
- Conference rooms
- Stairwells
- Executive, open, and private offices

FEATURES

- Multi-Technology: By using both PIR and U/S signals, the sensor minimizes false triggering for high reliability
- Isolated Relay: Supports HVAC or other Class 2 low voltage signals
- Supports both 24VAC/VDC power supplies
- Wide Coverage: Units from 500 to 2000 sq. ft. available
- Self-Adjusting: Internal microprocessor continually analyzes, evaluates and adjusts the sensitivity and time delay. Performance is kept at a maximum and user complaints are eliminated.

- Custom white color matched for most common daylight harvesting architecture
- Uses OSPxx Series Power Pack: uses Class 2, 24 volt wiring, three wire connection (low voltage). Multiple sensors can control single or multiple power packs
- Additional mid-range lens assembly included for applications with mounting heights between 12'-20'
- Fast, simple installation: easy ceiling mount, twist-lock sensor attachment for 360° rotation and flexibility
- Small motion sensitivity: The ultrasonic technology provides excellent small motion sensitivity
- Timer setting feature: automatic—30sec-30min. Test mode—4sec with auto exit programming
- Non-volatile memory: learned and adjusted settings saved in protected memory are not lost during power outages
- Walk-through: provides increased energy savings by decreasing the time delay to 2.5min when someone momentarily walks through the monitored space
- Ultrasonic components: one or two U/S transducers and one or two narrow bandwidth receivers each 16mm in diameter. Frequency—Crystal controlled to $\pm 0.005\%$.
- Device: rugged, high-impact, injection molded plastic, white. Color coded leads 7" (17.78 cm)

OSCxx-RMW

Leviton Manufacturing Co., Inc. Global Headquarters

201 North Service Road, Melville, NY 11747-3138 tech line 800-824-3005 fax 800-832-9538

©2023 Leviton Manufacturing Co., Inc. All rights reserved. Subject to change without notice.

PRODUCT DATA

HOW THE OSCxx-R AUTOMATICALLY ADAPTS

Condition	Example	Adaptive Reaction
Timer Left In Test Mode - The sensor remains in an 4 sec. test mode.	An installer accidentally leaves the sensor in the 4 sec. timer test mode and the lights may go off or on every 4 sec.	The sensor automatically resets the timer to 10 min after 15 min of test mode.
False-On - The sensor incorrectly turns the lights on.	The sensor detects movement in the corridor or hall way and the room lights turn on.	After an initial movement is sensed, if another movement is not sensed within the timer setting then the delayed off time setting is automatically reduced by 25%. Minimum time delay of 5 minutes.
False-Off - The sensor incorrectly turns the lights off.	The sensor does not detect movement because an occupant sits virtually motionless at a desk and the lights turn off.	If motion is sensed within a short period after the lights go off, then the current delayed off-time setting is increased by 50%. Maximum time delay is 30 minutes.

DIP SWITCH SETTINGS

SWITCH	BANK A	SWITCH FUNCTIONS	SWITCH SETTINGS
	BANK A	OFF	ON
A1	Single/Multi-tech	Multi-Tech	Single Tech
A2	PIR/Ultrasonic	PIR**	Ultrasonic
A3	Manual Mode	Auto Adapting Enabled	Auto Adapting Disabled
A4	Walk-Thru Disable	Walk-Thru Enabled	Walk-Thru Disabled
	BANK B		
B1	Override to On	Auto Mode	Lights forced On
B2	Override to Off	Auto Mode	Lights forced Off
B3	Test Mode	OFF'ON'OFF	Enter/Exit Test Mode
B4	LED Disable	LEDs Enabled	LEDs Disabled

*Bold items are factory defaults

**This setting is only used if the Single Technology Option (Switch A1) is selected

FIELD-OF-VIEW

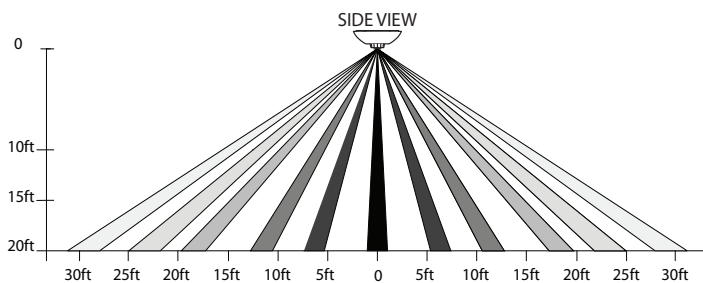
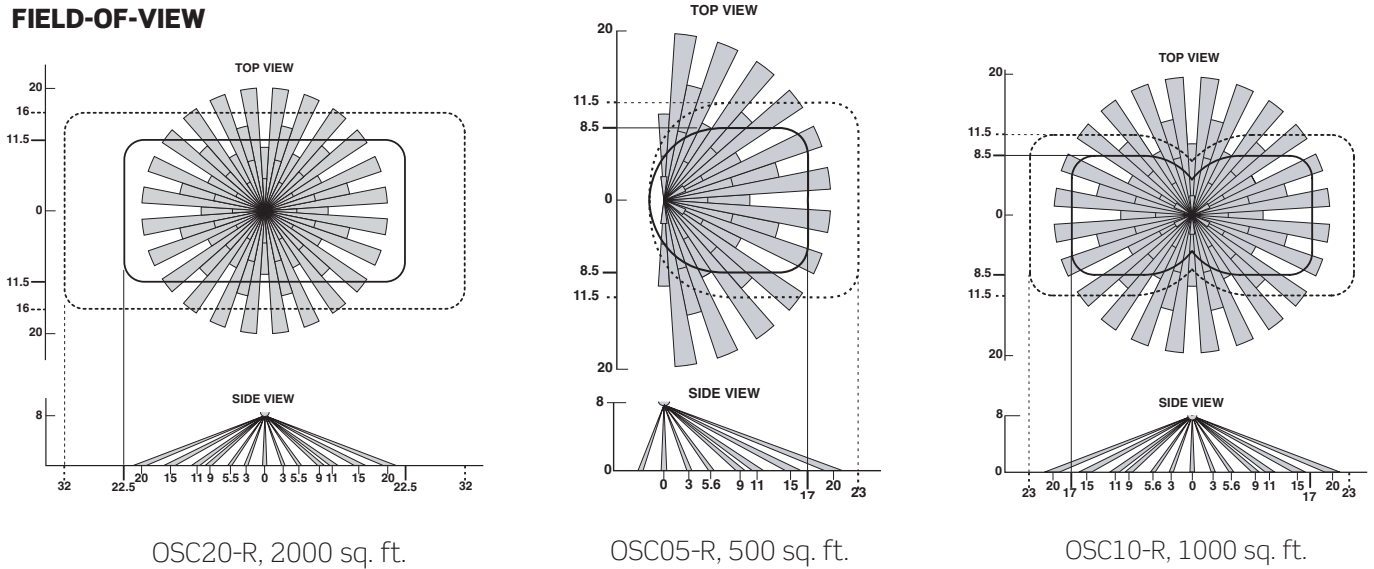

- Major Motion, PIR
- Major Motion, U/S
- Minor Motion, U/S

PHYSICAL WIRING

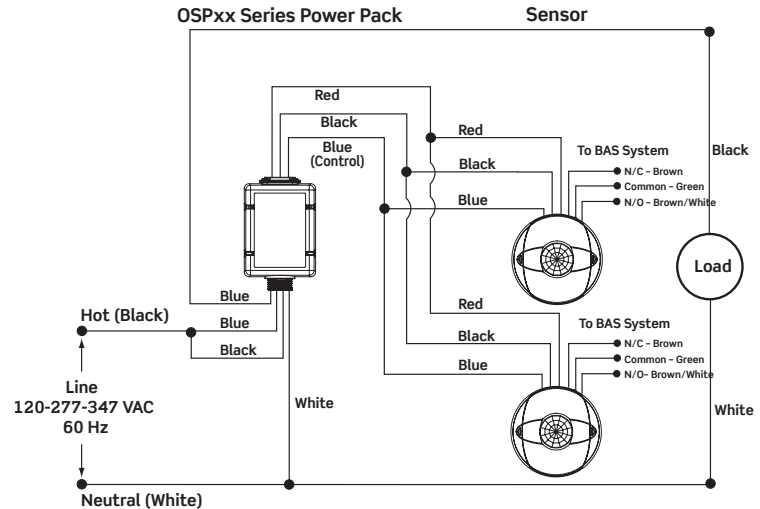
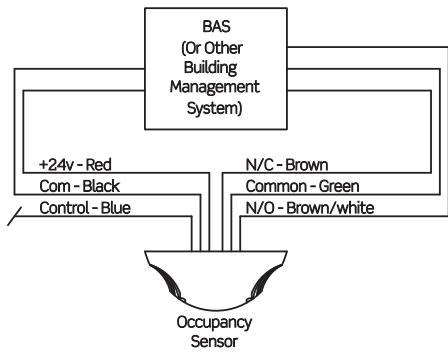

SPECIFICATIONS

ELECTRICAL	
Power Requirements	15-28 VAC/VDC from OSPxx Power Pack or other Class 2 power supplies
Isolated Relay	1A @ 30VAC/VDC
Power Consumption	DC: OSC05: 30mA, OSC10: 40mA, OSC20: 32mA AC: OSC05: 45mA, OSC10: 50mA, OSC20: 50mA
Output	24 VDC active high logic control signal with short circuit protection
CONTROLS	
Ultrasonic Frequency	OSC05/OSC10: 40kHz OSC20: 32kHz
Ultrasonic Sensitivity	0-100%; green knob (factory setting: 50%)
Infrared Sensitivity	0-100%; red knob; (factory setting: 75%)
Time Delay	30sec-30min; black knob (factory setting: 10min)
INDICATORS	
Green LED	U/S motion technology
Red LED	Infrared motion technology
ENVIRONMENTAL	
Operating Temperature Range	32-104°F (0-40°C)
Relative Humidity	0-95% non-condensing, for indoor use only
OTHER	
Mouting Height	Low-range lens (default, black) 8-12 feet Mid-range lens (red) 12-20 feet
Dimensions	4.2" W x 1.57" D
Listings	CUL/US Certified, can be used to comply with ASHRAE 90.1 and 2016 Title 24 Part 6 occupancy sensing requirements
Warranty	Limited Five-Year Warranty
ORDERING INFORMATION	
CAT NO.	DESCRIPTION
OSC05-RMW	Multi-Technology Ceiling Sensor, 500 sq. feet of coverage
OSC10-RMW	Multi-Technology Ceiling Sensor, 1000 sq. feet of coverage
OSC20-RMW	Multi-Technology Ceiling Sensor, 2000 sq feet of coverage

Made in USA with globally sourced components and NAFTA compliant models available.

Leviton Manufacturing Co., Inc. Global Headquarters

201 North Service Road, Melville, NY 11747-3138 tech line 800-824-3005 fax 800-832-9538

©2023 Leviton Manufacturing Co., Inc. All rights reserved. Subject to change without notice.

PRODUCT DATA

OSCxx-RMW

Leviton Manufacturing Co., Inc. Global Headquarters

201 North Service Road, Melville, NY 11747-3138 **tel** 800-323-8920 **fax** 800-832-9538 **tech line** (8:30AM-7:00PM ET Mon-Fri) 800-824-3005

Leviton Manufacturing Co., Inc. Energy Management, Controls and Automation

10385 SW Avery St., Tualatin, OR 97062 **tel** 800-736-6682 **fax** 503-404-5594 **tech line** (6:00AM-4:00PM PT Mon-Fri) 800-959-6004

Visit our Website at: www.leviton.com/sensors

©2023 Leviton Manufacturing Co., Inc. All rights reserved. Subject to change without notice.

G-8579C/K23-am
REV NOV 2023