

GreenConnect Wireless Companion Switch and Dimmer



Description

GreenConnect delivers simple wireless lighting control by adding wireless control to virtually any switching or dimming load. Compatible with various lamp fixtures and load control devices, GreenConnect offers a scalable and flexible wireless solution to meet the control needs of virtually any space. No new wiring, room controller, hub or commissioning required. Ideal for retrofits and new construction.

The GreenConnect Wireless Companion Switch and Dimmer pair wirelessly with a GreenConnect load controller to provide a simple to install solution for wireless manual lighting control. The GreenConnect Wireless Companion Switch and Dimmer are the perfect solutions for locations where installing a new device, wallbox, or wiring is difficult or cost-prohibitive.

User Interfaces

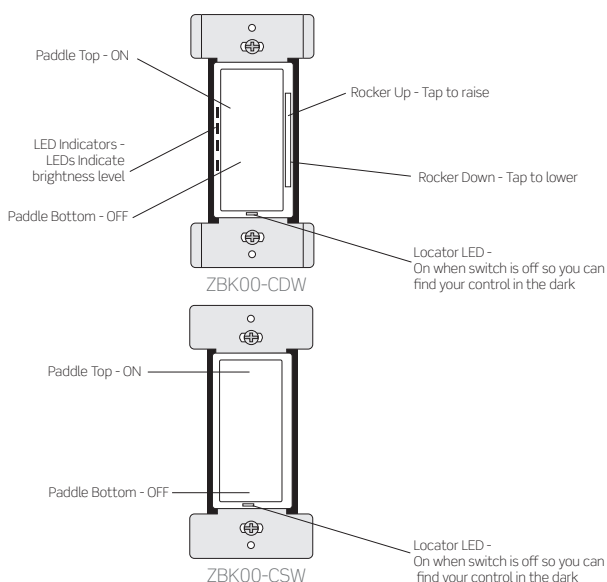

Features

- True wireless, multi-way switching or dimming when paired with a GreenConnect load controller, dimmer, or switch
- LED indicators for light level and locating in a dark room
- Mounts directly to the wall surface or into a single or multi-gang wall-box
- Wireless range of 50ft
- Classic Decora® rocker with dimming bar for simple ON/OFF and raise/lower control
- Use with single or multi-gang Decora® wall-plates
- Easy to replace CR2025 batteries with an estimated battery life of five years
- Complies with IEEE 802.15.4 standards for domestic and international wireless networks
- Can be used as a component in a system to meet code requirements for IECC, ASHRAE 90.1, and 2022 Title 24, Part 6 space/are control, dimming, manual-ON/OFF, occupancy/vacancy control and automatic shutoff requirements

Installation Diagram

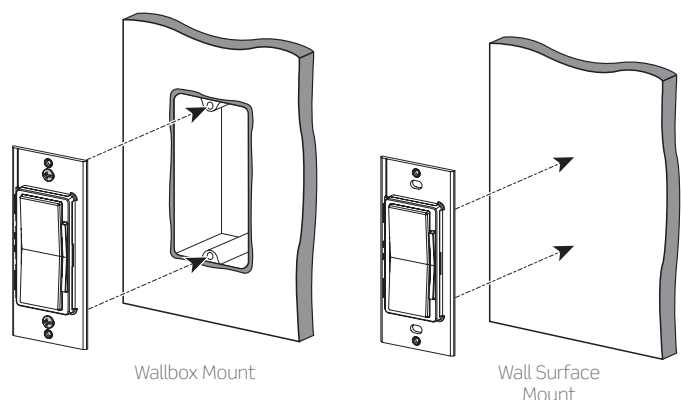

Leviton Manufacturing Co., Inc. Lighting & Controls

10385 SW Avery Street, Tualatin, OR 97062 tel 800-736-6682 tech line (6:00AM-4:00PM PT Mon-Fri) 800-959-6004

©2024 Leviton Manufacturing Co., Inc. All rights reserved. Subject to change without notice.

Dimensions Diagram

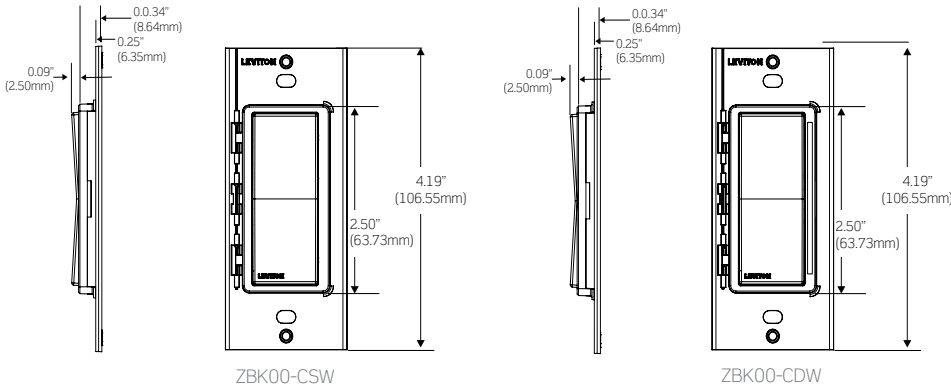

Specifications

Electrical	
Batteries	CR2025 x2.3V
Wireless	
Network	2.4GHz
Range	50 ft
Environmental	
Operating Temperature	32° to 104° F (0° to 40° C)
Storage Temperature Range	14° to 185° F (-10° to 85° C)
Relative Humidity	0-90% non-condensing
Other	
Energy Codes	Can be used as a component in a system to meet energy code requirements for IECC, ASHRAE 90.1, and 2022 Title 24, Part 6 space/area control, dimming, manual-ON/OFF, occupancy control and automatic shutoff requirements
IP Rating	IP10
Listings	UL 1472, CSA C22.2 No. 184.1-15, FCC Part 15, Class B
Weight	0.15lbs (0.07kg)
Warranty	5-Year

Ordering Information

GreenConnect Wireless Companion Switch & Dimmer	
Cat. No.	Description
ZBK00-CSW	GreenConnect Wireless Companion Switch, Battery Powered, White
ZBK00-CDW	GreenConnect Wireless Companion Dimmer, Battery Powered, White

Leviton Manufacturing Co., Inc. Lighting & Controls

10385 SW Avery Street, Tualatin, OR 97062 **tel** 800-736-6682 **tech line** (6:00AM-4:00PM PT Mon-Fri) 800-959-6004

Leviton Manufacturing Co., Inc. Global Headquarters

201 North Service Road, Melville, NY 11747-3138 **tel** 800-323-8920 **tech line** (8:00AM-10:00PM ET Mon-Fri, 9:00AM-7:00PM ET Sat, 9:00AM-5:00PM ET Sun) 800-824-3005

Visit our Website at: www.leviton.com/greenconnect

©2024 Leviton Manufacturing Co., Inc. All rights reserved. Subject to change without notice.