

Emergency Lighting Transfer Switch

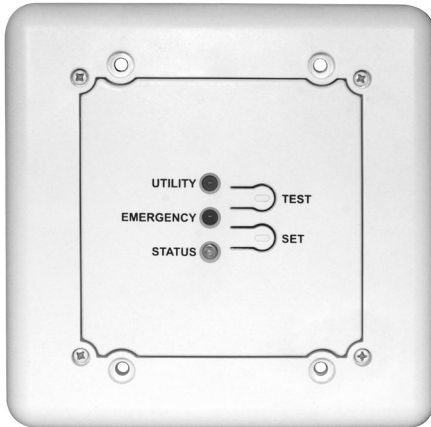

DESCRIPTION

The Emergency Lighting Transfer Switch (ECD00-D0W) is a single-zone, silent emergency transfer control with universal dimming capabilities. It can be used with 2- and 3-wire line voltage dimming systems, as well as 0-10V and DALI.

The ECD00-D0W allows emergency lighting to be dimmed with normal lighting during normal operating times. In the event of a utility power interruption, the ECD00-D0W will automatically transfer designated emergency fixtures from the dimming control to the emergency power source and bring them to full brightness, regardless of whether the dimming system is in operation or turned off.

APPLICATIONS

Ideal for designated dimmable emergency luminaires in public places such as:

- Auditoriums
- Restaurants
- Conference rooms
- Theaters
- Classrooms
- Retail spaces
- Municipal buildings
- Houses of worship

FEATURES

- Slim, aesthetically pleasing universal mount enclosure allows flush, surface, panel and box mounting
- Utility and emergency power indicator LEDs
- Integral front mounted test switch
- Voltage surge protection

FEATURES, CONT.

- Includes field-selectable automatic testing and fire alarm interface options
 - N/C type—when contact is closed, will transfer to emergency source
 - N/O type—when contact is open, will transfer to emergency source
- Triple interlock (electrical, mechanical and time delay) maximizes safety and reliability by eliminating arcing and the potential for phase-to-phase shorts between separate power sources during transfer
- Oversized 50A rated relay contacts allow high inrush loads to be used safely and reliably—tested at over 5,000 cycles
- Works with both inverter and generator systems, normally-on and normally-off type
- Allows for emergency lighting to be dimmed with normal lighting during normal operation

SPECIFICATIONS

ELECTRICAL	
Sensing Input	120-277V
Load Rating	120-277V (16A)
Ballast Load Rating	16A Magnetic/16A Electronic
Incandescent Load	1920W (120V)/4432W (277V)
Warranty	5 Year
MECHANICAL	
Mounting	4-11/16" back-up box, no plaster ring required
Rating	UL1008
Shipping Weight/Color	1.125 lb (0.51 kg)/White
Ambient Temperature	32 to 140°F (0 to 60°C)
Flush Mounted Size	6x6x0.5" (152.4x152.4x12.7mm)
Body Size	4x4x2.3" (101.6x101.6x58.4mm)

Emergency Lighting Transfer Switch

PRODUCT DATA



Emergency Lighting Transfer Switch

2-WIRE DIMMABLE LOADS

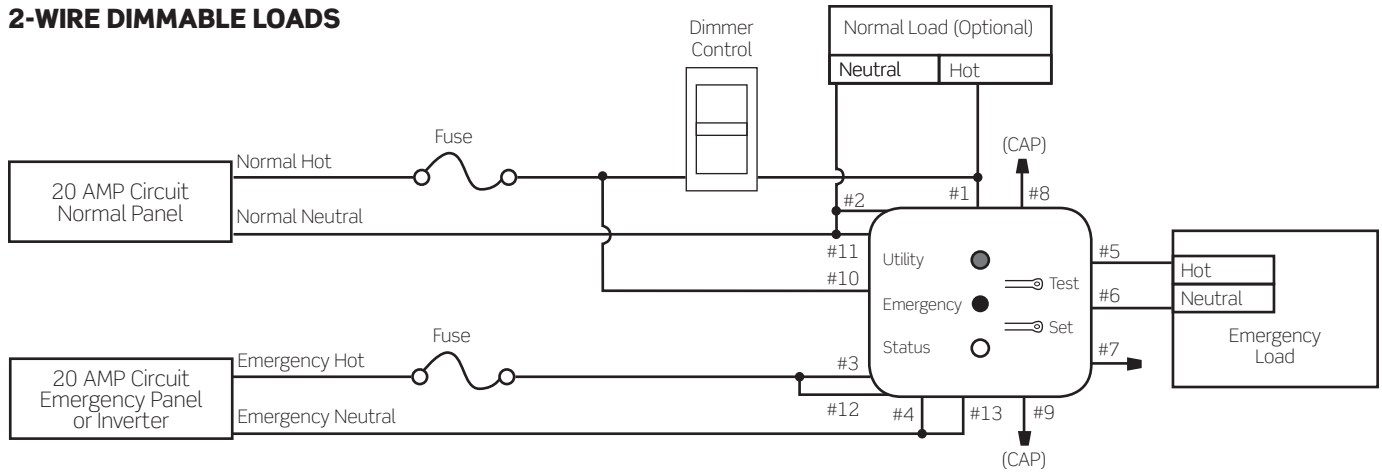

3-WIRE DIMMABLE LOADS

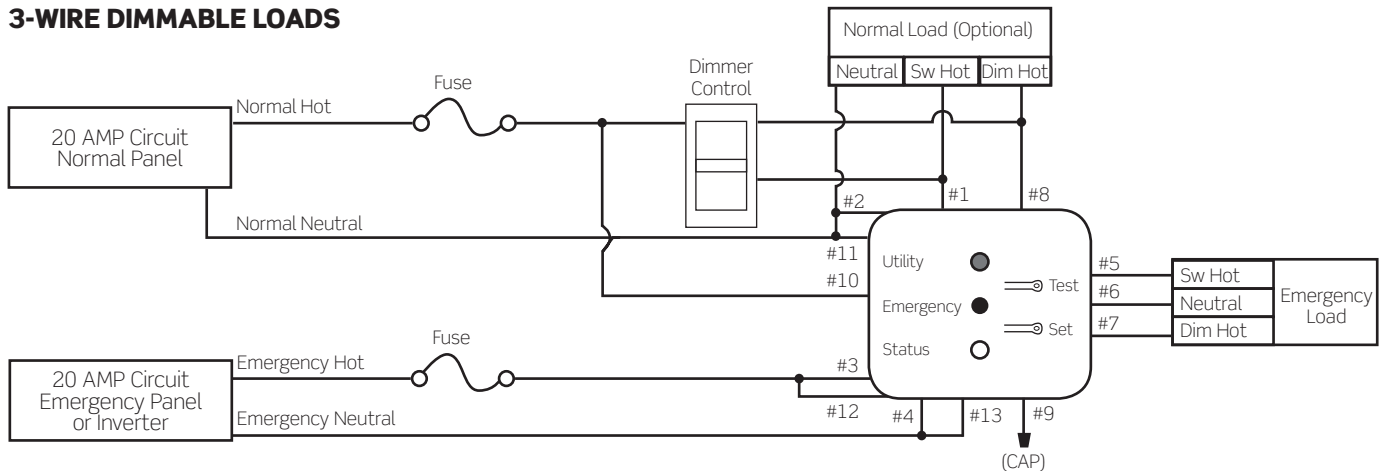

4-WIRE DIMMABLE LOADS (0-10V, DALI)

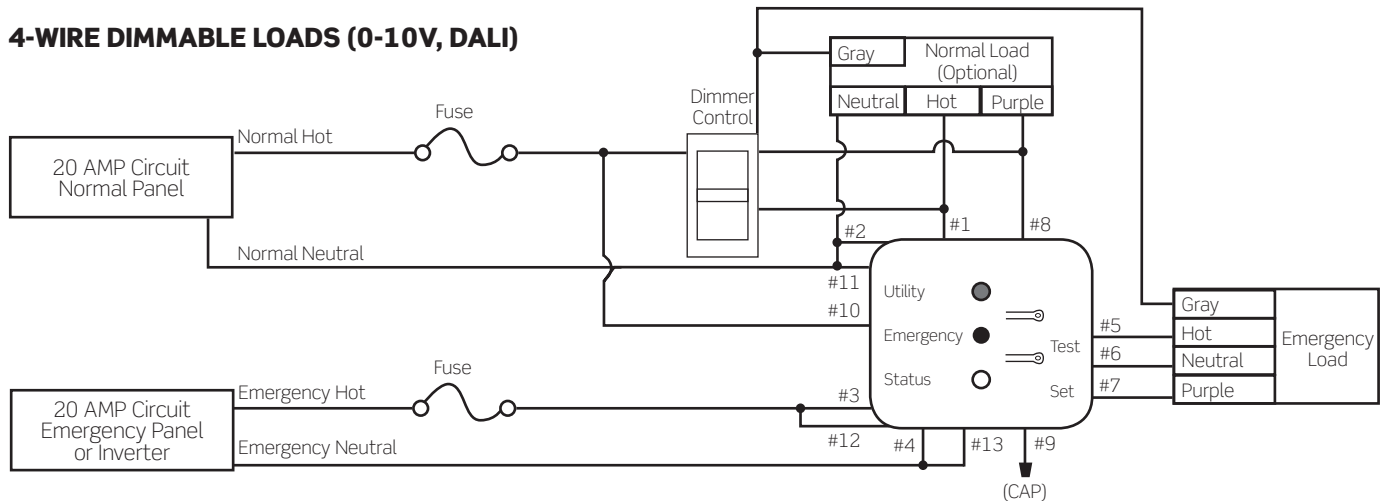

ORDERING INFORMATION

CAT. NO.	DESCRIPTION
ECD00-D0W	Emergency Lighting Transfer Switch
ECD00-FUS	Fuse and fuseholder accessory kit—meets UL1008 requirements for Short Circuit Rating (5000A)

Leviton Manufacturing Co., Inc. Energy Management, Controls and Automation

20497 SW Teton Avenue, Tualatin, OR 97062 tel 800-736-6682 fax 503-404-5594 tech line (6:00AM-4:00PM PT Mon-Fri) 800-959-6004

Leviton Manufacturing Co., Inc. Global Headquarters

201 North Service Road, Melville, NY 11747-3138 tel 800-323-8920 fax 800-832-9538 tech line (8:30AM-7:00PM ET Mon-Fri) 800-824-3005

Visit our Website at: www.leviton.com

©2018 Leviton Manufacturing Co., Inc. All rights reserved. Subject to change without notice.

G-10276/L18-tb