

Decora® Wall Switch PIR Vacancy Sensor with LED NightLight



NightLight Off



NightLight High Level

BASIC OPERATION

The Decora® Wall Switch Passive Infrared (PIR) Vacancy Sensor with LED NightLight (OSS10) uses a PIR vacancy sensor to detect motion from a heat-emitting source within its field-of-view to automatically switch lights OFF, offering the same performance features as the ODS family of occupancy sensors. OSS10 has the ability to reduce (dim) and turn off the “Guide Light” function with a simple dial setting. The LED NightLight consumes less than 1/2 W providing energy savings and guide lighting when room lights are off.

APPLICATIONS

The OSS10 is perfect for use in hospitality and health care facilities with night light feature to guide to manual-ON. The adjustable time delay settings of 30 seconds to 30 minutes will automatically turn lights OFF.

The OSS10 can be used to provide automatic lighting control for energy savings and convenience in a variety of commercial applications, including:

- Hotel & hospital restrooms
- Conference rooms
- Small offices
- Storage areas
- Classrooms
- Lounges
- Bathrooms

FEATURES

- Fits in standard wallbox and replaces single-pole wall switch; ground and neutral connection required. Gangable with other units.
- Low-profile design eliminates obtrusive “scanning-device” look. Elegant Decora wallplates complement any interior for sleek aesthetics; uses Decora wallplates and coordinates with Leviton’s popular line of Decora wiring devices.
- 180° field-of-view provides approximately 2100 SF of coverage
- Convenient pushbutton provides manual-ON/OFF light switching at any time
- Two dual element PIR sensors used to widen detection range and double the detection points within the FOV
- Segmented Fresnel lens provides optimum sensitivity and performance. Designed with an extensive “minor motion” area where even slight body movements will be detected.
- Vandal resistant PIR lens

OPTIMAL LED DESIGN

Exclusive LED High Inrush Stability (H.I.S.) circuitry designed to handle the high inrush electronic ballast loads of today’s LED lighting and offer unmatched durability and service. Our true Zero-Cross Relay switches are at the zero crossing point of the AC power curve, ensuring maximum contactor life and compatibility with LED ballasts. Leviton Occupancy and Vacancy Sensors are the premiere choice for LED compatibility.

OSS10

Leviton Manufacturing Co., Inc. Global Headquarters

201 North Service Road, Melville, NY 11747-3138 tech line 800-824-3005 fax 800-832-9538

©2023 Leviton Manufacturing Co., Inc. All rights reserved. Subject to change without notice.

PRODUCT DATA

FEATURES CONT.

- Blinders—horizontal field-of-view may be adjusted between 180° and 60° of arc by using integral blinders located on either side of the lens. No masking tape required.
- Manual-ON/auto-OFF mode for installations where manual-ON switching is required but auto-OFF switching is still desired
- A red LED indicator light flashes when sensor detects motion to verify detection is active and can be used to comply with 2016 Title 24, Part 6 requirements for occupancy sensing
- Time Delay adjustment for delayed-OFF time settings of 30 seconds (for walking test), 10 minutes, 20 minutes, and 30 minutes. Allows customized adjustments to maximize energy savings.
- Vacancy confirmation—when the time out expires and the relays turn OFF, a 30 second vacancy confirmation exists to turn the relays back ON
- False detection circuitry
- LED NightLight offers “Guide Light” functionality
- Adjustable NightLight illumination setting for continuous or dimmed NightLight
- NightLight Mode—the factory default setting for the NightLight Mode is Dimmed Mode. This means the NightLight will automatically dim to 5% of full brightness after 2 minutes of no occupancy when activated by the internal light sensor.
- One unit can be used for 120V through 277V lighting. Compatible with both electronic and magnetic ballasts.

INSTALLATION

The OSS10 is preset to deliver optimum performance in a wide variety of applications without requiring any adjustments during installation. The unit may replace a single-pole wall switch mounted in a standard wall box. The unit must have a neutral and be properly grounded in order to operate. The unit’s integral blinders may be used to restrict the field-of-view to prevent unwanted detection of hallway traffic. It should be positioned at least 6 feet away from HVAC registers. Note that whenever the unit is powered up, it will take approximately 1 minute to begin normal operation.

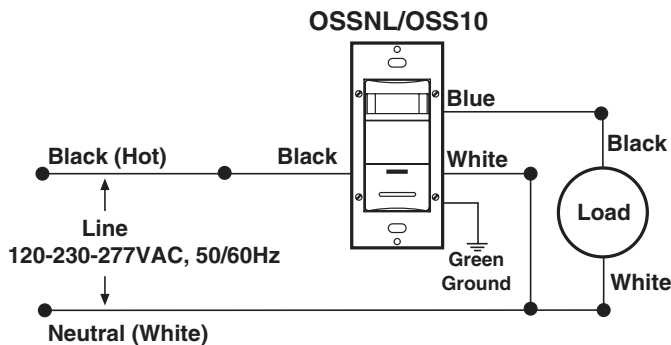

OSS10 Wall Switch Occupancy Sensor Wiring Diagram,
Single Location Control

FIELD OF VIEW

The OSS10 provides a 180° field of view with a maximum coverage area of approximately 2,100 square feet. The maximum sensing distance in front of the sensor is 40 feet, and at each side is 30 feet. A “minor-motion” zone detects relatively small body movements and allows the lights to stay ON even though a person may not be moving or walking around the room. The remainder of the field of view, the “major-motion” zone, exhibits a lesser degree of sensitivity and requires larger movements.

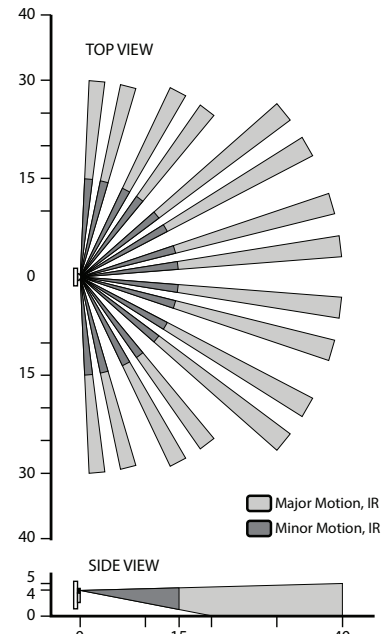

DIAGRAMS

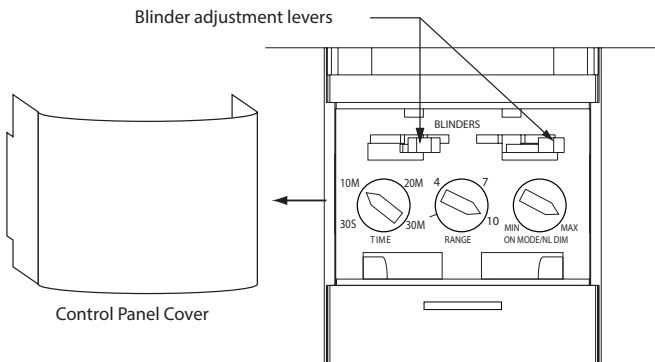

OSS10 Sensor Features

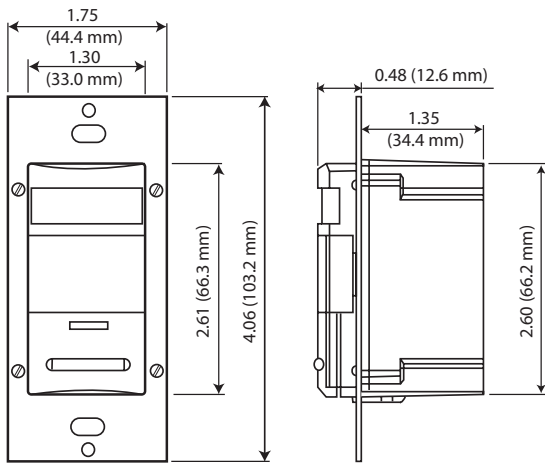

Dimensions Night Light

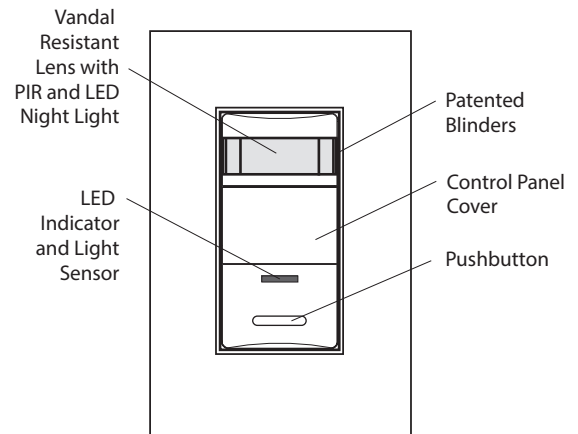

PRODUCT DATA



SPECIFICATIONS

ELECTRICAL	
Line Voltage	120-230-277VAC
Power Consumption	120V, Nightlight OFF - 190mW 120V, Nightlight ON max - 350mW 277V, Nightlight OFF - 250mW 277V, Nightlight ON max - 410mW
Operational Frequency	60Hz
Wire Designation	Line - Black Load - Blue Ground - Green Neutral - White
Load Rating	Fluorescent: 1200VA @ 120V, 2700VA @ 277V Incandescent: 800W @ 120V, Motor - 1/8 HP @ 120V
ENVIRONMENTAL	
Operating Temperature Range	32-122°F (0-50°C)
Storage Temperature Range	14-185°F (-10-85°C)
Relative Humidity	20-90% non-condensing
OTHER	
Listings	UL/cUL Certified, NOM
Energy Codes	Can be used to comply with IECC, ASHRAE 90.1, and 2019 Title 24, Part 6 vacancy sensing requirements
Warranty	Limited Five-Year Warranty

ORDERING INFORMATION

CAT. NO. *	DESCRIPTION
OSS10-INx	Vacancy Sensor Wall Switch with NightLight

To indicate color, add suffix to the end of the catalog number.

White (-W), Ivory (-I), Black (-E)

*Made in USA with globally sourced components and NAFTA compliant models available.

Leviton Manufacturing Co., Inc. Global Headquarters

201 North Service Road, Melville, NY 11747-3138 **tel** 800-323-8920 **fax** 800-832-9538 **tech line** (8:30AM-7:00PM ET Mon-Fri) 800-824-3005

Leviton Manufacturing Co., Inc. Lighting & Controls

10385 SW Avery St., Tualatin, OR 97062 **tel** 800-736-6682 **fax** 503-404-5594 **tech line** (6:00AM-4:00PM PT Mon-Fri) 800-959-6004

Visit our Website at: www.leviton.com/sensors

©2023 Leviton Manufacturing Co., Inc. All rights reserved. Subject to change without notice.

G-8943C/K23-am
REV NOV 2023

OSS10