

Sahara Architectural Wall Box Dimmers



BASIC OPERATION

The Leviton Sahara line of architectural wall box dimmers are designed for a wide range of power loads (400W, 600W, and 1500W) in a wide variety of commercial applications. The Sahara wall box dimmers conform to the IEC British “3x3” size standard and are available for incandescent, tungsten, magnetic low voltage and electronic low voltage loads. Sahara wall box dimmer models for use with remote control are also available.

APPLICATIONS

Leviton’s Sahara wall box dimmers are the cost effective choice for commercial and residential installation. The Sahara wall box dimmer line is ideal for:

- Residential rooms
- Corridors
- Commercial offices
- Anywhere lighting level control is desired

FEATURES

- Location Indicator: Illuminated when dimmer is OFF for easy location in a dark room.
- Easy operation
 - Press bottom portion of push pad until it clicks to turn ON/OFF.
 - Press the toggle switch on the upper right of the pad to adjust the dimming level.
 - Lights will return to previous dimmed level each time the light is turned ON.
- LED light level indicator will track up or down corresponding light levels as adjustments are made.
- Clean and stylish appearance
 - 3.75” x 3.75” size conforms to BS 4662 and BS 5733 electrical box standards.
 - No visible heat sinks, fins, or mounting hardware.
- Power failure memory: light is restored to the same levels set prior to the power failure or interruption.

PRODUCT DATA



WIRING DIAGRAM

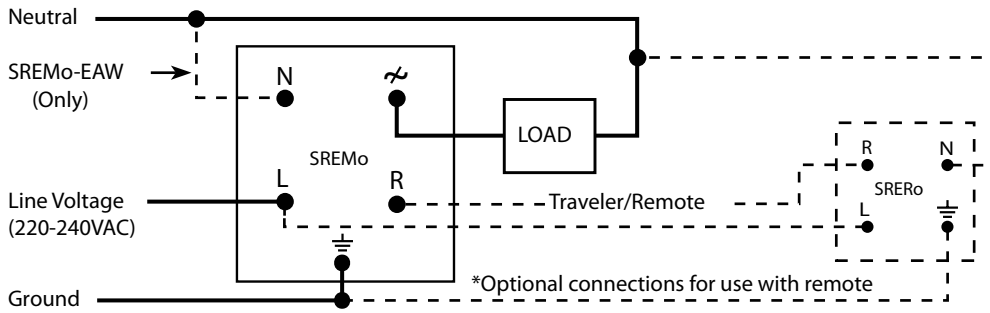

SPECIFICATIONS

ELECTRICAL	
Input	220-240VAC @ 50Hz Line Voltage Regulation
MECHANICAL	
Controls	Push ON/OFF switch control
LEDs	<ul style="list-style-type: none"> The locator LED will be lit when the load is off The LED light level indicator will be lit when the load is on to indicate the dimming level
ENVIRONMENTAL	
Operating Temperature Range	32°F to 122°F (0°C to 50°C)
Non-Operating Temperature Range	23°F to 185°F (-5°C to 85°C)
Relative Humidity	0% to 90% non-condensing,
OTHER	
Physical	9.525 x 9.525 CM / 3.75" x 3.75" .3 lbs/136.08g
Warranty	Limited Five-Year Warranty

ORDERING INFORMATION

CAT NO.	LOAD TYPES	DESCRIPTION
SREMo-IAW	Incandescent and Tungsten	600W Dimmer with Blue LED, White
SREMo-IBW	Incandescent and Tungsten	1500W Dimmer with Blue LED, White
SREMo-EAW	Incandescent, Tungsten, Magnetic Low Voltage and Electronic Low Voltage	400VA Dimmer with Blue LED, White
SREMo-MAW	Incandescent, Tungsten, and Magnetic Low Voltage	600VA Dimmer with Blue LED, White
SRERo-IAW	Incandescent and Tungsten	600W Multi-Remote Dimmer with Blue LED, White
SRERo-MAW	Incandescent, Tungsten, and Magnetic Low Voltage	600VA Multi-Remote Dimmer with Blue LED, White

Leviton Manufacturing Co., Inc. Lighting & Energy Solutions

201 N. Service Rd. Melville, NY 11747-3138 Tech Line: 1-800-824-3005 Fax: 1-800-832-9538 www.leviton.com/les

Leviton Manufacturing of Canada, Ltd.

165 Hymus Boulevard, Pointe Claire, Quebec H9R 1E9 • Telephone: 1-800-469-7890 • FAX: 1-800-563-1853

Leviton S. de R.L. de C.V.

Lago Tana 43, Mexico DF, Mexico CP 11290 • Tel. (+52) 55-5082-1040 • FAX: (+52) 5386-1797 • www.leviton.com.mx

Visit our Website at: www.leviton.com/les

© 2011 Leviton Manufacturing Co., Inc. All rights reserved. Subject to change without notice.

G-8593/F11-cb