



User Guide

Z-MAX™ REMOTE RELAY PANELS

LIGHTING CONTROL RELAY PANELS

...another Z-MAX™ product by Leviton Manufacturing

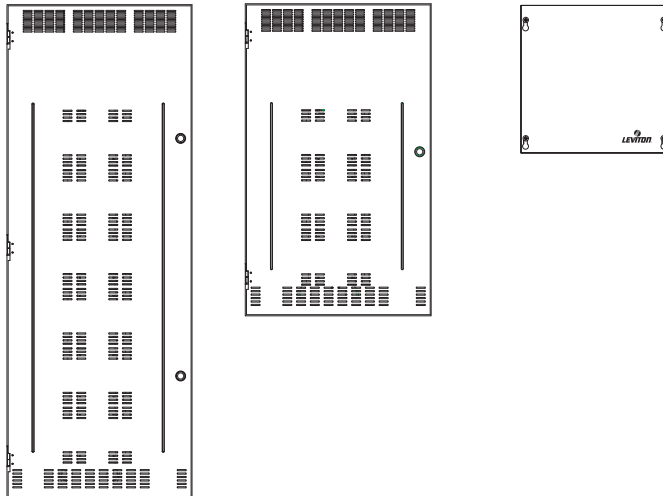

Table of Contents

Overview	
Introduction	1
Installation Overview	1
Inspection	2
Physical Description	2
Control Overview	3
Conduit Entry Locations	4
Line & Load Circuit Wiring	4
Turn On	4
Warnings	5
Installation	6
Installation Checklist	6
Relay Cabinet Mounting	9
Flush Mounting	9
Special Instructions for Flush Mount Kit Installation	10
Selection of a Mounting Location	12
Suggested Mounting Heights	12
Environmental Considerations	12
Preferred areas for conduit entry	13
Suggested Layouts	16
Physical Mounting Requirements	17
Step-by-step Mounting	20
Master/Slave Network Topology	
Network Topology	22
Network Layout Planning	23
Relay Numbering Chart	25
Relay Numbering Chart	26
Feed and Load Wiring	
Overview of Power Wiring - Feed\Line Wiring	27

Table of Contents,

Line and Load Circuit Wiring	30
Testing the Circuits.....	30
Installing Relay Cards	30
Wiring the relays.....	31
Control Electronics Power Wiring	38
Circuit Schedule	41
Master/Remote Network Interconnection	
RJ-45 Pinout	46
Termination	47
How to Terminate Relay Cabinets.....	49
Low Voltage Control Wiring	
Input Trigger - What determines an "ON"	52
Low Voltage Input Terminals & Connections.....	54
Connecting Low Voltage Switches	
Connecting Low Voltage Switch	58
Occupancy Sensors	
Occupancy Sensor Wiring	61
Photocells	
Photocell Wiring	63
Wiring with an External Power Supply.....	65
Power Considerations for Control Systems.....	67
Terminology	67
Power Requirements & Maximum Run Length	68
Power Wire - Run Length.....	73
Configuration	75
Out of the Box Configuration.....	75
Remote/Slave Cabinet Configuration.....	75
Comments & Examples on Relay Numbering	76
Configuration of Remote Relay Cabinets with Dipswitches	76
Table of MRN Codes & Starting Relay Number	77

Configuration of Remote Relay Cabinets without Dipswitches or via USB	78
Configuration of Master Control Panel	79
Enable Master/Slave Communication	79
Enabling Master/Slave Communication	80
Setting the Total number of Remote Relays	80
Communication Verification	82
Conclusion	82
Warranty Information	85

Table of Contents,

Overview

Introduction

The Z-MAX Remote Relay Panels, also referred to as Z-MAX Slave Relay Cabinets, are designed for remote installation and mounting where relay switching from 4 to 48 load circuits is desired, but control intelligence, programming, and interface to other systems is required at a central location. This system of remote relay panels has the following benefits over the traditional configurations:

- Remote mounting of relays where control electronics are inconvenient
- Single point of programming when a continuous extension of an existing relay panel is desired
- Other unique applications where configuring at the relay itself is not desired

Installation Overview

Installing a remote relay cabinets involves only a few steps:

- Step 1:** Mounting the relay cabinet to the wall, install conduit, and pull all wire.
- Step 2:** Terminate line voltage wiring
- Step 3:** Terminate any low voltage wiring
- Step 4:** Terminate the Master/Slave networking wiring
- Step 5:** Inspect your work
- Step 6:** Power-up, configure, and test the system

Each of the above steps are covered in detail throughout the rest of this user's guide. In each section notes, warnings, requirements, suggestions, and procedures are included which will help you be successful in the installation and use of your system.

Inspection

Carefully unpack the relay cabinet, and inspect to make sure there is no hidden shipping damage. Report any damage to the freight carrier who delivered the system. Claims for damages are filed with the freight carrier.

In case of damaged components, your relay cabinet may be serviced in the field with factory replacement parts.

Physical Description

Remote relay panels are classified by the number of load circuits they can switch. The fewer the number of controlled circuits, the smaller the overall cabinet dimensions, and the larger the number of controlled circuits, the larger the overall cabinet dimensions. The physical properties of the cabinets are as follows:

Model	# of Relays	Flush Option	Weight	Dimensions - in. (CM)
re4sd	4 (fixed relays)	No	10.6 lbs. (4.83 Kg)	10" W x 10" H x 4 9/32" D (25.4 x 25.4 x 10.44)
r24sd	0-24 (accepts Z-MAX relay modules)	Yes	44 lbs. (19.96 Kg)	20 1/4" W x 34" H x 4 9/32" D (54.4 x 86.4 x 10.9)
r48sd	0-48 (accepts Z-MAX relay modules)	Yes	65 lbs (29.48 Kg)	20 1/4" W x 54" H x 4 9/32" D (54.4 x 137.2 x 10.9)*

Cabinet Properties

Some of the relay features are:

- UL & cUL Listed for use in USA and Canada
- Compliant with NEMA requirements
- Easy to install

- Quick & Easy to Configure

The control portion of the relay cabinet employs all digital circuitry for accuracy and minimum wiring requirements between the relay cabinet and its control systems.

Control Overview

The Leviton Z-MAX remote relay cabinets use an intelligent central control card (Digital Main Control Module) and a dedicated system of networking wiring, allowing for control of the relays in the remote cabinet from any control source connected to the master relay cabinet and from any low voltage source connected to the remote relay cabinet.

Control input to a remote relay cabinet can be any combination of the following:

- Low Voltage momentary or maintained
- Momentary 2-Pole On/Off
- Photocell 0-10VDC or Switched
- Occupancy sensor
- 0-10VDC analog
- Dry Contacts

Following the basic premise of remote relay cabinet, even though each remote relay cabinet can accept control inputs, these inputs are processed by the master control panel for configuration and relay control.

Remote relay cabinets require a dedicated physical network of certified category-5 wiring utilizing RJ-45 connectors at each end. The panels should be laid out in a linear "daisy-chained" fashion. In the event that this network topology is not convenient, hubs and/or routers may be available to facilitate this topology. Contact the factory for additional information.

Conduit Entry Locations

The cabinets have been designed with specific locations supporting conduit entry for line and low voltage circuits. There are specific areas of the cabinet which are restricted from some or all types of conduit access. Reference the Physical Installation section of this manual for specific details.

Line & Load Circuit Wiring

Each relay requires line & load circuit wiring. The line wiring should come from an over-current device and the load circuit wiring shall go to the specific load to be controlled. On some models which have integrated branch circuit protection, the line side of the relay has been pre-wired to a circuit breaker. With these products, only the load side of the circuits needs to be connected.

Turn On

Prior to turn on, verify the following is installed correctly:

- Feed wiring
- Load wiring
- Control wiring

Warnings

- To be installed and/or used in accordance with appropriate electrical codes and regulations.
- To be installed by a qualified Electrician.
- DO NOT CONNECT line voltage wires to low voltage terminals.
- Mount in a location where audible noise is acceptable.
- When using with fluorescent ballasts, both lighting fixture and ballast must be grounded.
- Use this relay cabinet only with minimum 75° C copper wire at 75% ampacity.
- Disconnect power when servicing the relay cabinet, fixture or when changing lamps.
- Indoor use only.
- TO AVOID FIRE, SHOCK OR DEATH: TURN OFF POWER AT MAIN CIRCUIT BREAKER, OR FUSE, AND TEST THAT THE POWER IS OFF BEFORE WIRING, OPENING THE PANEL, OR REPLACING ANY COMPONENT!
- During operation, cabinet cover is to be removed by qualified personnel ONLY! Heed all caution markings indicating the presence of High Voltage. High voltage may be up to 600V.
- Test each circuit for short circuits before connecting it to relay so damage to the relay and it's electronics can be avoided.

Installation

Installation Checklist

Install the cabinets by following these simple steps:

- Step 1:** Unpack the system
- Step 2:** Report any damage to the freight carrier
- Step 3:** If appropriate, remove any covers and/or doors
- Step 4:** If appropriate, remove the mounting plate assembly and store where damage will not occur to the electronics
- Step 5:** Attach the cabinet to the wall (reference stickers inside the cabinet for proper orientation if it is in question)
- Step 6:** Drill conduit entry holes if KO's are not provided and attach conduit where appropriate
- Step 7:** Pull all wire into the cabinet
- Step 8:** Test & Verify all wiring by directly connecting line to load - Correct any faults and re-test wiring prior to proceeding
- Step 9:** Re-install any control electronics removed in step #4
- Step 10:** Terminate the feed & load wiring to each relay
- Step 11:** Terminate control wiring
- Step 12:** Verify feed wiring
- Step 13:** Verify load wiring
- Step 14:** Verify master/slave network wiring
- Step 15:** Blow out dust, dirt, or debris which has accumulated in the cabinet
- Step 16:** Apply power to the system
- Step 17:** Verify proper operation of each relay using the override buttons
- Step 18:** Make adjustments to remote slave starting relay number if necessary and reset the system

- Step 19:** Make programming adjustments at the master control module so that newly installed remote relays usage correctly.

Relay Cabinet Mounting

There are several steps required when mounting your relay cabinet:

- Step 1:** Install the flush mounting kit if appropriate
- Step 2:** Plan your conduit runs & layout
- Step 3:** Plan your physical mounting, the connection between the cabinet and the wall
- Step 4:** Mount the cabinet to the wall

Flush Mounting

The 4 relay cabinet is designed only for surface mounting. However, the other relay cabinets have a flush mount kit option which is available as an accessory. The part numbers for these kits are as follows:

Cabinet Size/Type	Flush Trim Kit Part Numbers
8	RAC00-08F
24	RAC00-24F
48	RAC00-48F

Special Instructions for Flush Mount Kit Installation

- Step 1:** Locate where the cabinet will be hung in the wall. Choose a location in a dry area that is convenient to the branch circuit panel
- Step 2:** Be careful to remove the ground wire from the door. It is attached using a spade connector. No tools are required
- Step 3:** Remove the door by sliding the door up and off its hinges. You will have to unlock the door first using the supplied key
- Step 4:** On the 8 Cabinet you will also have to remove the ribbon cable from the LCD display
- Step 5:** Set the door aside in a safe place
- Step 6:** Cut out the drywall if needed
- Step 7:** Tap out the mounting hole knockouts located on the sides of the cabinet. See the figure on the next page for the location of the knockouts on each cabinet
- Step 8:** Attach the unit to the wall. Use #10 (with washer) hardware. 1/4" hardware can be used, but the mounting holes will need to be drilled out to 5/16"
- Step 9:** Install the flush frames as shown in the figure below using the screws provided

The 24 cabinet is shown, but the process is similar for the 8 and 48 cabinet.

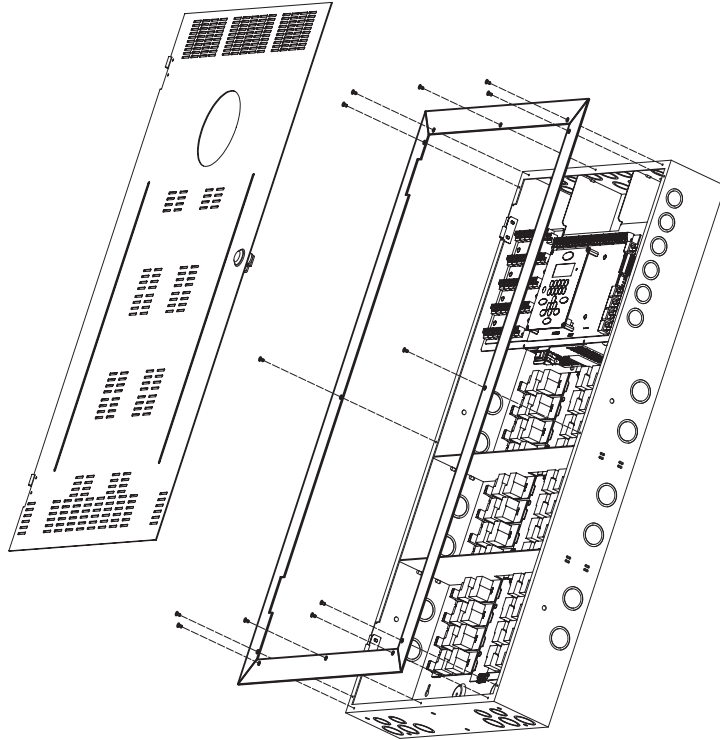

Step 10: Remove the nut holding the door lock in place

Step 11: Remove the lock and its trim ring (Looks like a washer)

Step 12: Discard the trim ring and reinstall the lock

Step 13: Loosen the screws holding the door hinges to the cabinet. This will allow the hinges to move in their slotted holes

Step 14: Install the door onto its hinges

Step 15: Open the door 90 degrees and insert a quarter (or something with similar thickness) between the door and the frame

Step 16: Push the door against this spacer and tighten the hinge screw

Step 17: Remove the spacer

Step 18: Remove the door and proceed to the next section

Selection of a Mounting Location

Choosing a mounting location for your cabinet is critical to the overall success and ease of installation. Each style of cabinet has its unique wiring requirements which must be observed. Please review the next few pages, which describe and illustrate these mounting requirements.

Suggested Mounting Heights

Although successful operation is completely independent of mounting height, the suggested mounting heights below were selected to locate the cabinet at a reasonable and accessible working height.

Cabinet	Suggested Mounting height to bottom of cabinet
4 Relay Cabinet	62" (157 cm)
8 Relay Cabinet	53" (1,359 mm)
24 Relay Cabinet	32" (826 mm)
48 Relay Cabinet	12" (318 mm)

Environmental Considerations

- Cabinets generate heat (see table which follows). Make sure they are mounted in a climate controlled space where the temperature will be 0-40° C (32-104°F)
- Reinforce the wall for strength as required for weight and local code
- Clearance on left and right side of the panel should be maintained at 1 1/2 " or greater
- Relays will click while in operation. Locate the panels where audible noise is acceptable.

Cabinet	MAX BTU/HR
4 Relay Cabinet	97
8 Relay Cabinet	245
24 Relay Cabinet	583
48 Relay Cabinet	1166

Preferred areas for conduit entry

Your relay cabinet has been designed to be easy to install with a variety of installation options to fit many applications. However, there still are specific considerations which must be made. One of these is the allowed, and in some cases disallowed, areas for conduit entry. Disallowed areas are areas where conduit entry is impossible. These areas are clearly marked in the following illustrations. Once you recognize the disallowed areas for conduit entry, you can look at the allowed areas. Each cabinet style has designated areas for low voltage and line voltage conduit entry. This must be observed for proper code compliance.

Please review the following illustrations which indicate preferred, allowed, and disallowed areas for conduit entry.

Conduit Entry

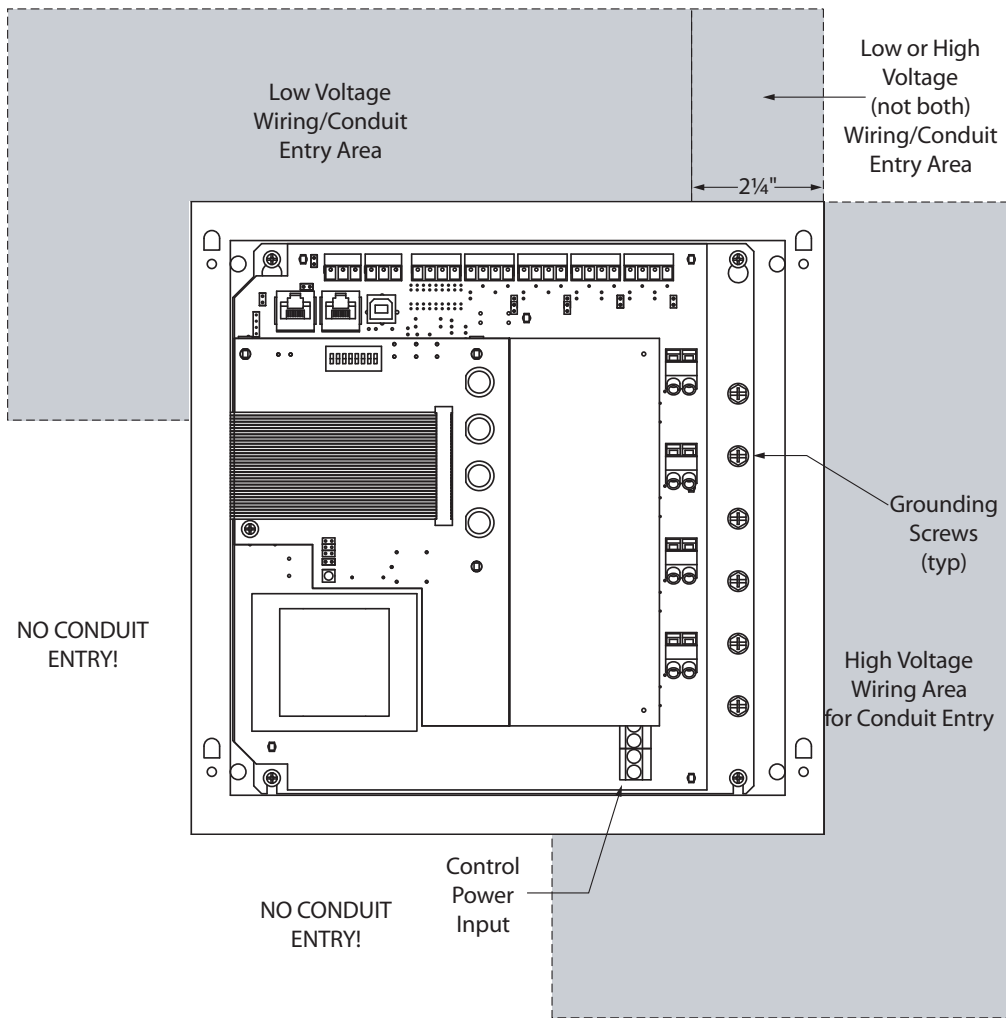

4 Relay Cabinet Conduit Entry

, Preferred areas for conduit entry

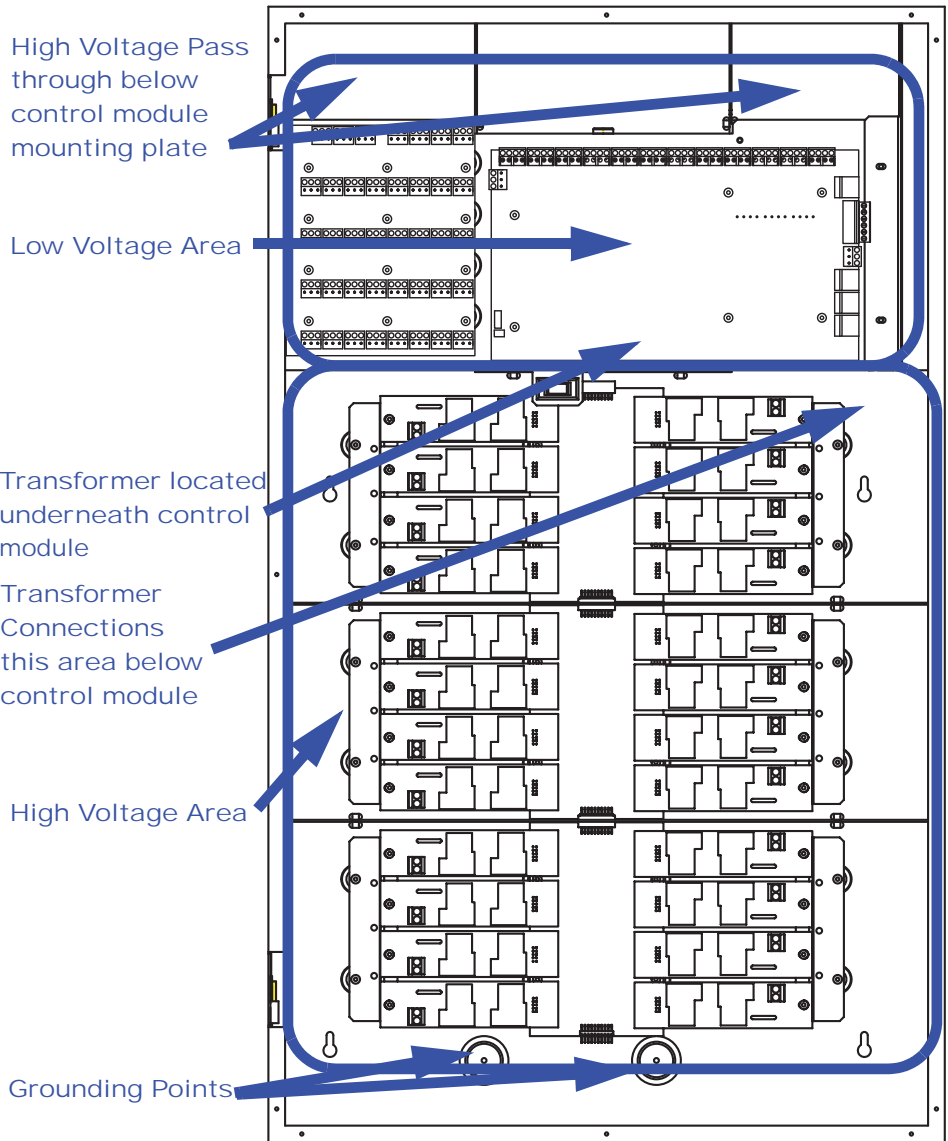

24 & 48 Relay Cabinets Conduit Entry (24 relay cabinet shown, 48 similar)

Suggested Layouts

The "right" layout for your application is a decision only you can make. The layouts depicted in the following illustrations show some simple and effective systems which you're welcome to use and adapt to your particular installation.

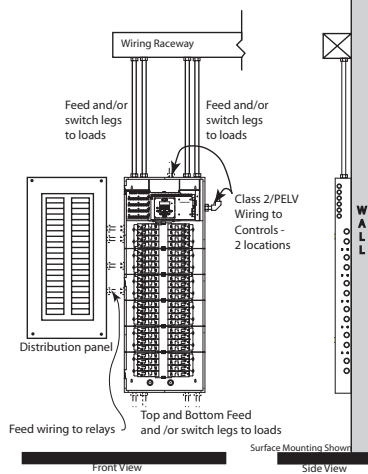
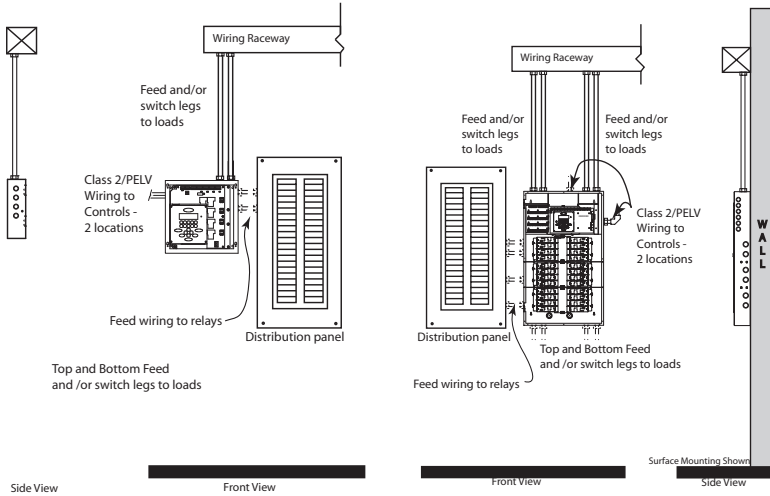

Physical Mounting Requirements

Each relay cabinet style has a different set of mounting locations, dimensions, and requirements. Please review the illustrations below which show the details for each cabinet type.

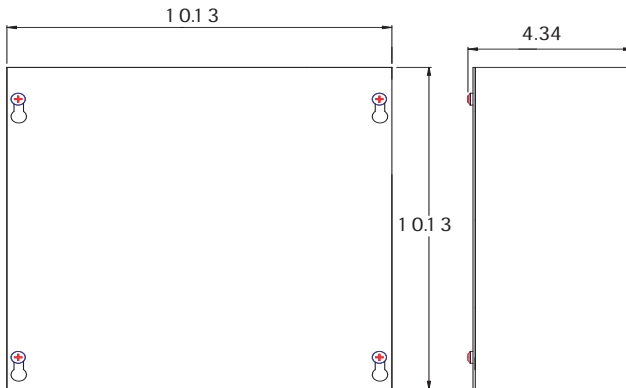

FRONT VIEW
(all dimensions in inches)

SIDE VIEW
(all dimensions in inches)

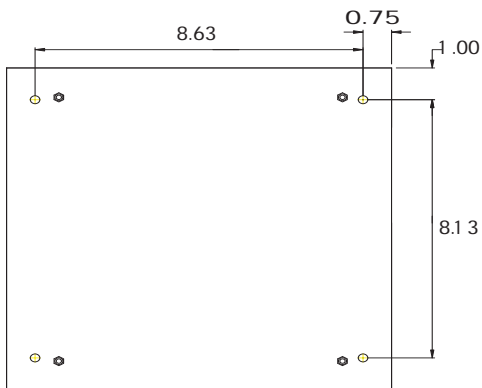

MOUNTING HOLES VIEW
(all dimensions in inches)

4 Relay cabinet

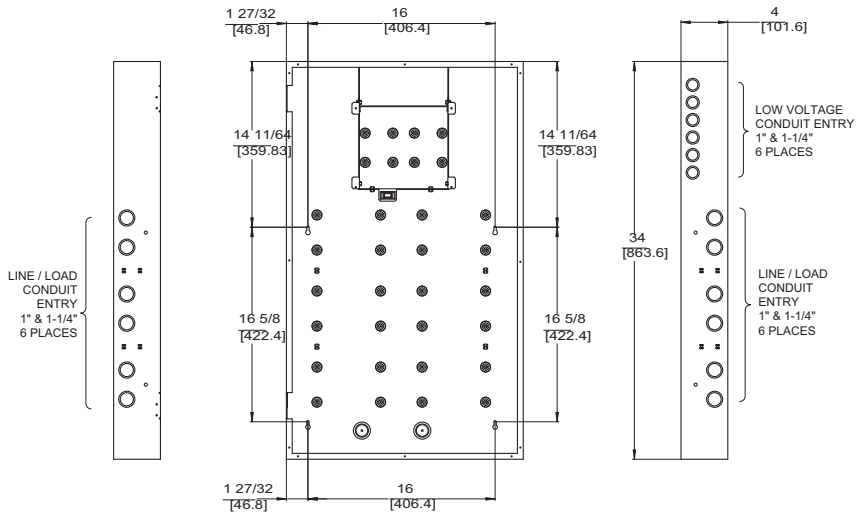
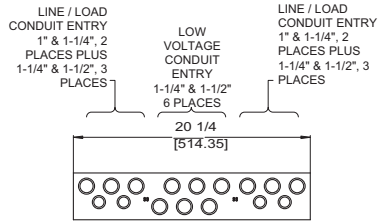

All Dimensions are in inches
[] are mm



LINE / LOAD CONDUIT ENTRY: 1" & 1-1/4", 4 PLACES PLUS 1-1/4" & 1-1/2", 6 PLACES

24 Relay cabinet

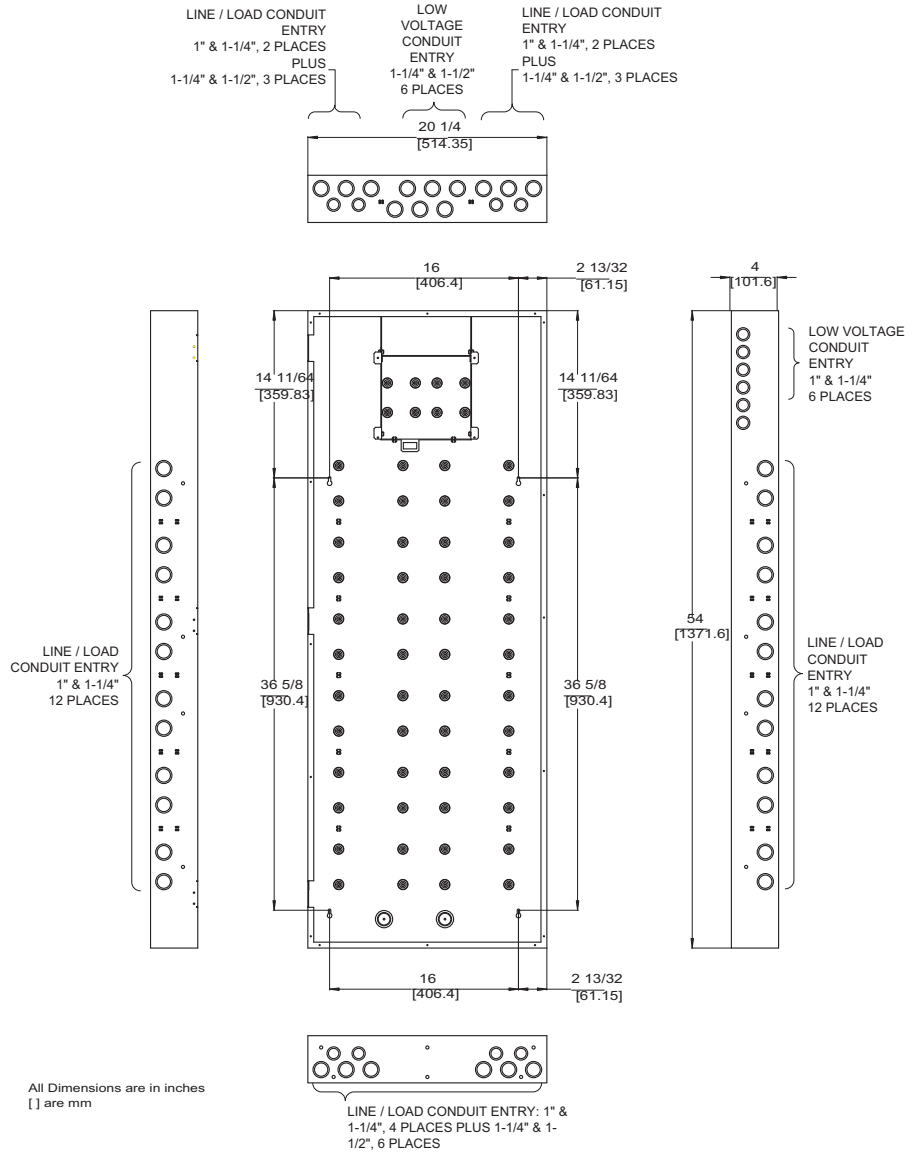

48 Relay cabinet

Step-by-step Mounting

- Step 1:** Locate where the cabinet will be hung on the wall. Choose a location in a dry area that is convenient to the branch circuit panel.
- Step 2:** Leviton requires that cabinet mounting hardware reach through the drywall to wall studs or other suitable solid backing. However, properly sized struts and suitable hardware can be used. They must distribute the load to the anchors without exceeding the recommended anchor limit. Using drywall screws directly through drywall without a stud is not acceptable. Make sure that there is adequate support.
- Step 3:** Remove the cover. Some cabinets may require the removal of data and/or grounding wires. Make sure that this occurs prior to removal of the door and that they are reconnected when reinstalling the door. On cabinets with hinges, simply lift the door off the hinges. On cabinets with screws, remove the cover screws. Appropriately store the cover for future use.
- Step 4:** On the (4) relay remote relay panel only, locate the mounting plate assembly attached to the back of the enclosure. Locate the 4 mounting screws in the 4 corners of the rear plate. Loosen these 4 screws. Lift the entire assembly up and out of the enclosure.
- Step 5:** Prior to proceeding, reference the following figures which show the location of the mounting holes and allowed conduit entry locations for each cabinet type.
- Step 6:** Orient the enclosure so that the "UP" arrow on the label inside the enclosure is pointing up. Note that the high-voltage conduit access is through the right end of the bottom, the right side and the right end of the top. Note that the low-voltage (Class 2) conduit access is through the top end of the left side and the left end of the top. Cut or punch the desired conduit openings. Do not cut openings in the back of the enclosure or the bottom end of the left side or the left end of the bottom as it will no longer be possible to re-install the electrical assembly.

Master/Slave Network Topology

There are some basic rules and requirements of Master/Slave networks which must be observed for your network to function. These rules are as follows:

Specification	Description
Maximum End to End Run Length	1500 feet
Maximum number of relays per network	96 (Master + Slave)
Maximum number of nodes on the network	250
Network Topology	Daisy-Chain
Interconnection Method	Category 5e or better wire with RJ-45 connectors
Maximum number of master panels per master/slave network	1
Recommended Wire	Belden 1700A or Equivalent
Network Protocol	Z-MAX Master/Slave over CAN

NOTE

Any combination/mix of remote relay panels may be used on a single Master/Slave network so long as there is only one master and you do not exceed the maximum number of relays per network.

Network Topology

All Master/Remote panels must be connected in a daisy-chained fashion. For example, please consider the illustrations below:

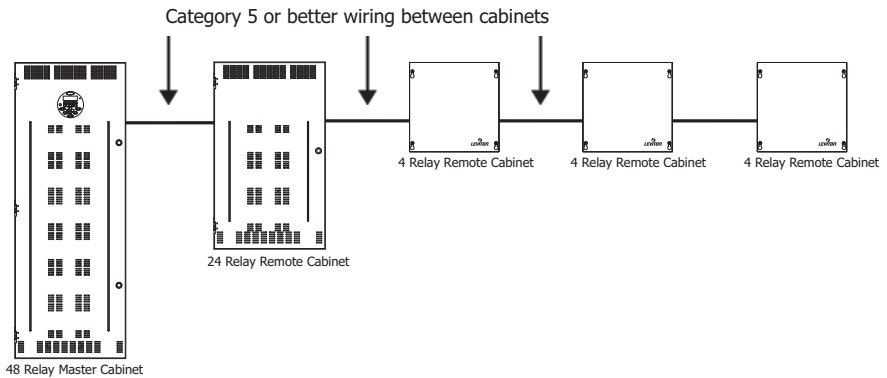

The right way - Daisy-Chain Wiring

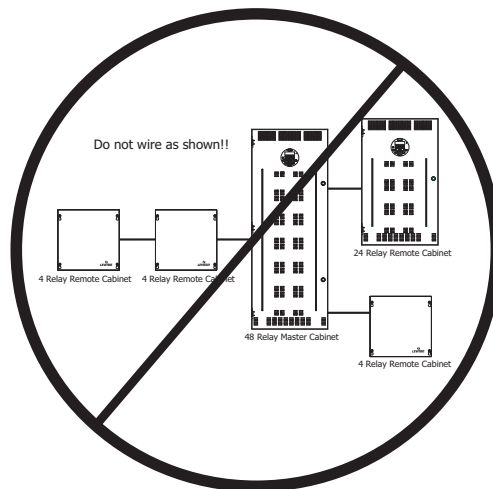

The wrong way - Star or other scheme

Network Layout Planning

The previous section illustrated some of the technical requirements and physical layout for Master/Slave networks. When planning your network, it's equally important when considering the numbering of relays.

Relays are divided into two types: local and network. The local relays are the relays inside the master cabinet, and the network relays are the remote or slave cabinet relays. By default, all relay cabinets are configured for 1-48 "local" relays, and all slave cabinets without dipswitches are out of the box programmed to start at relay number 49.

No two relays can have the same relay number and there are a limited number of relay numbers available on a Master/Slave network. In some installations it may make sense to decrease the number of local relays to only the number of actual relays in the master cabinet so that the total number of controlled relays per network can be maximized.

Example 1 - 48 Relay Master, 24 Relay Remotes

A (48) relay master cabinet and a (24) relay slave cabinet is the required equipment for your project. The number of local relays in the master is by default 48 which matches the number of local relays, so you're ok. Also, by default, the (24) relay slave cabinet starts at relay number 49. Considering the facts of this example, everything is OK using the default settings. In summary:

- Master Cabinet with (48) relays, relay numbers 1-48 (default)
- Remote Cabinet with (24) relays, relay numbers 49-72 (default)

Example 2 - 48 Relay Master, (2) 24 Relay Remotes

Extend the above example and add a second (24) relay remote cabinet. Remembering that by default the remote relay cabinets without dipswitches (like the 24) start at relay number 49, and remembering that we already have relay number 49-72 used in the first remote cabinet, we can conclude that the added remote

cabinet must be configured via USB to start at relay number 73.
In summary:

- Existing Master Cabinet with (48) relays, relay numbers 1-48
- Existing Remote Cabinet with (24) relays, relay numbers 49-72
- Added Remote Cabinet with (24) relays, relay numbers 49-96, must be reconfigured via USB since out of box the default setup is addressed to relay numbers 49-72 which would have been in conflict with the existing cabinet.

Example 3 - 8 Relay Master, (2) 24 Relay Remotes, (3) 4 Relay Remotes

In order to execute this example, with (68) total relays, it's required to decrease the number of local relays in the (8) relay master cabinet so that you can stay within the (96) relay maximum per master/slave network, relay numbers are contiguous, and the number of available relays are maximized.

First Let's look at the "out of the box" configuration:

- (8) Master cabinet, (8) relays, but # of local relays is 1-48
- (24) Remote #1, (24) relays, 49-72 (out of box config)
- (24) Remote #2, (24) relays, 49-72 (out of box config)
- (4) Remote #1, (4) relays, starting relay number 0 (out of box config)
- (4) Remote #2, (4) relays, starting relay number 0 (out of box config)
- (4) Remote #3, (4) relays, starting relay number 0 (out of box config)

You will note that there are substantial conflicts with the out of the box configuration.

Therefore, the new configuration will look like this:

- (8) Master cabinet, (8) relays, but # of local relays is 1-8
- (24) Remote #1, (24) relays, relay numbers 9-32
- (24) Remote #2, (24) relays, relay numbers 33-56
- (4) Remote #1, (4) relays, relay numbers 57-60
- (4) Remote #2, (4) relays, relay numbers 61-64

- (4) Remote #3, (4) relays, relay numbers 65-68

In order to achieve this configuration, the following configuration changes must be made:

- 1 The number of local relays, a setting under Global Defaults on the master cabinet, must be reduced to 8;
- 2 The two (24) relay cabinets must be configured from a PC over USB as starting relay numbers 9 and 33;
- 3 The three (4) relay remotes, must be configured via the control module dipswitch, for starting relay numbers 57, 61, & 65.

For instructions specific to your project, please contact our Technical Services Department. The phone number can be found on the back page of this manual.

Relay Numbering Chart

Leviton recommends that when planning your network, you fill out the chart on the following page, or other similar chart which you prefer to document your system. This completed chart should be stored with your master relay panel complete with the circuit schedules of all of the relay panels. For an example circuit schedule, see page 41.

Relay Numbering Chart

Panel #	Starting Relay #	Ending Relay #	Panel Name	Notes
P1	1			
P2				
P3				
P4				
P5				
P6				
P7				
P8				
P9				
P10				
P11				
P12				
P13				
P14				
P15				
P16				
P17				
P18				
P19				
P20				
P21				
P22				
P23				
P24				

Feed and Load Wiring

Overview of Power Wiring - Feed\Line Wiring

Wiring is simple. All you need is the following:

- Dedicated circuit for control power - Hot, Neutral and Ground
- Individual feeds from branch circuit breakers, input circuits
- Individual load wires leaving relays, output circuits.

NOTE

Since the panel is fed from multiple circuits, locate each one and lock-out each feed in the OFF position.

All cabinets have ample area for conduit entries for feed, load, and control wiring. Ensure that conduit entry is only in the allowed locations. Refer to the figures on the proceeding pages for permitted locations.

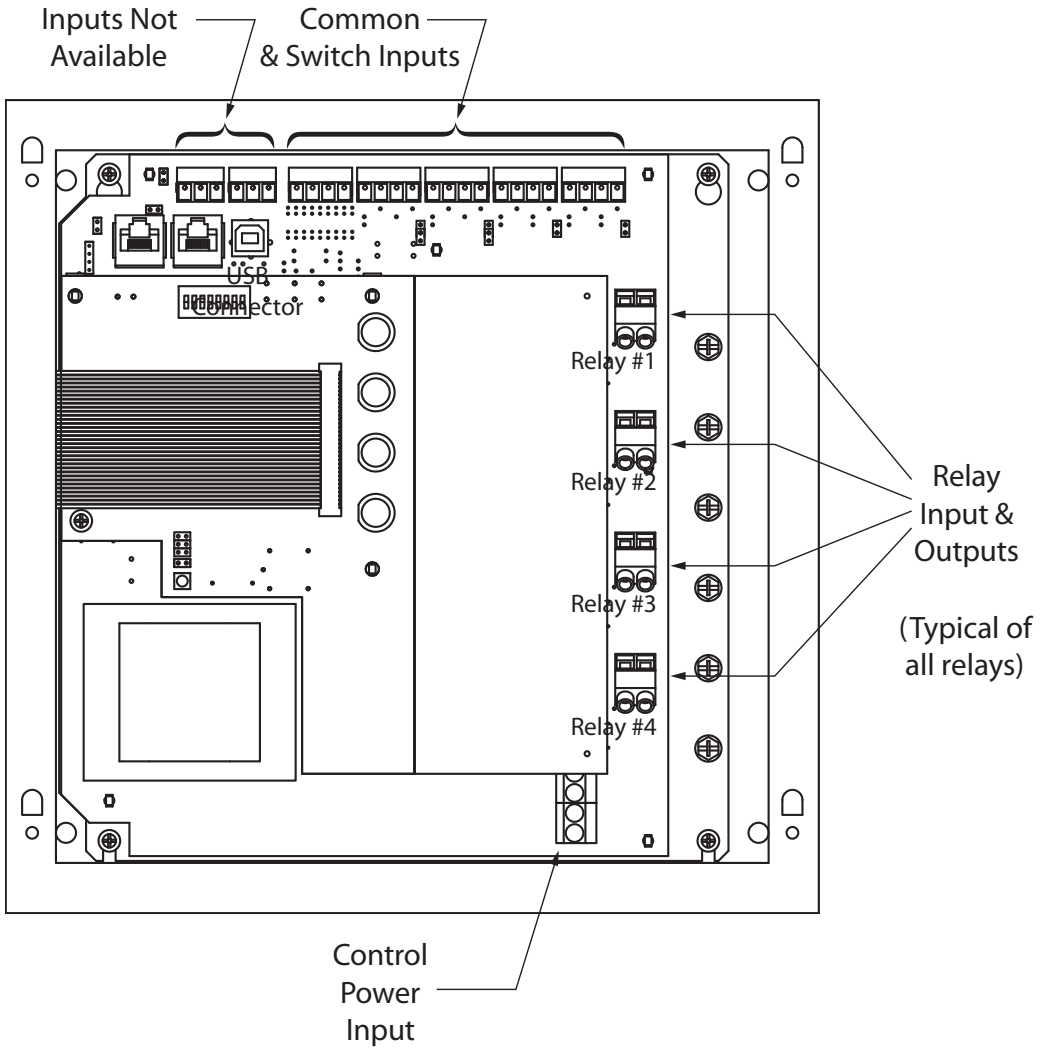

Cabinet Connections & Orientation, (4) Relay Panel

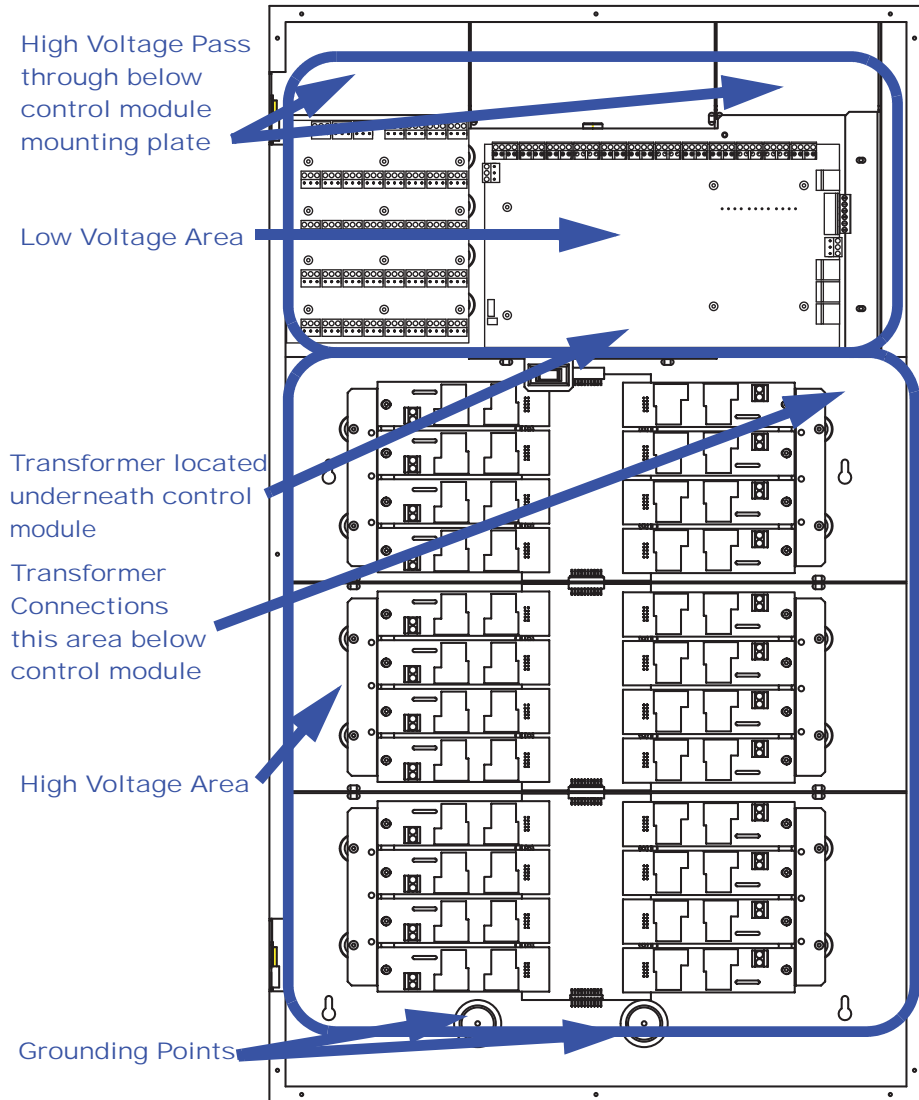

24 and 48 (not Shown) Cabinet Low Voltage and High Voltage Wire Connections

Line and Load Circuit Wiring

Z-MAX relay cabinets have multiple relay circuits of a specific type depending on the cabinet model. For details of the different relay types, please reference the chart on page 32.

Testing the Circuits

Prior to connecting any circuit to a relay, and after all load and feed connections have been made opposite the relay cabinet, test each circuit by following this procedure:

- Step 1:** Turn off the breaker feeding the circuit
- Step 2:** Ensure that all connections and wiring between the relay cabinet and the circuit breaker panel are complete
- Step 3:** Ensure that all connections and wiring between the relay cabinet and the load are complete
- Step 4:** At the relay cabinet, connect the feed(s) for relay #1 to the load for relay #1 with a wire nut or other appropriate means
- Step 5:** Energize the circuit by turning on the circuit breaker.
- Step 6:** Resolve any mis-wiring, shorts, etc. for the connected circuit
- Step 7:** Repeat the above steps for all circuits in all relay panels in your system. When all circuits have been tested, disconnect all Line's from Loads and proceed to the next section

Installing Relay Cards

On several relay cabinet models, the relays are removable. If you have one of these cabinets and need to add or remove relay modules, please follow these instructions:

Step 1: Locate the appropriate location for the relay card

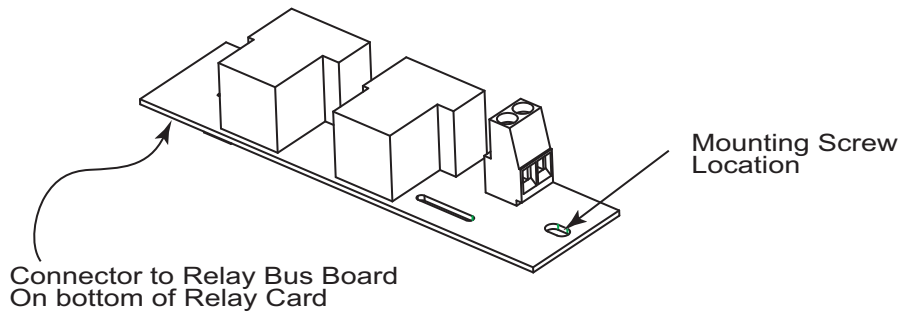

Step 2: Align the connector from the relay card with the relay bus board and gently push the two together.

Step 3: Once firmly seated, use a phillips screwdriver to drive the mounting screw tightly in place.

NOTE

If you need to remove the relay cards that shipped installed from the factory, remove the shipping screw located near the connector and discard. This screw is only required for shipping and not for installation.

Wiring the relays

Step 1: Connect the line (feed/circuit breaker) side of the circuit to the "input" terminal(s) on the relay card.

Step 2: Connect the load side of the circuit to the "output" terminal(s) on the relay card.

Step 3: Please note that relay card terminals accept the following wire sizes:

Relay Type	Wire Size	Wire Type	Torque
Z-MAX(Standard, 1-Pole)	20-8 AWG Copper	Solid or Stranded	7 in-lbs
2-Pole	20-6 AWG Copper	Solid or Stranded	20.5 in-lbs
347V	20-6 AWG Copper	Solid or Stranded	20.5 in-lbs
Latching	20-8 AWG Copper	Solid or Stranded	7 in-lbs

Wire Sizes for Relays

The diagrams on the following pages show how to wire the relay circuits.

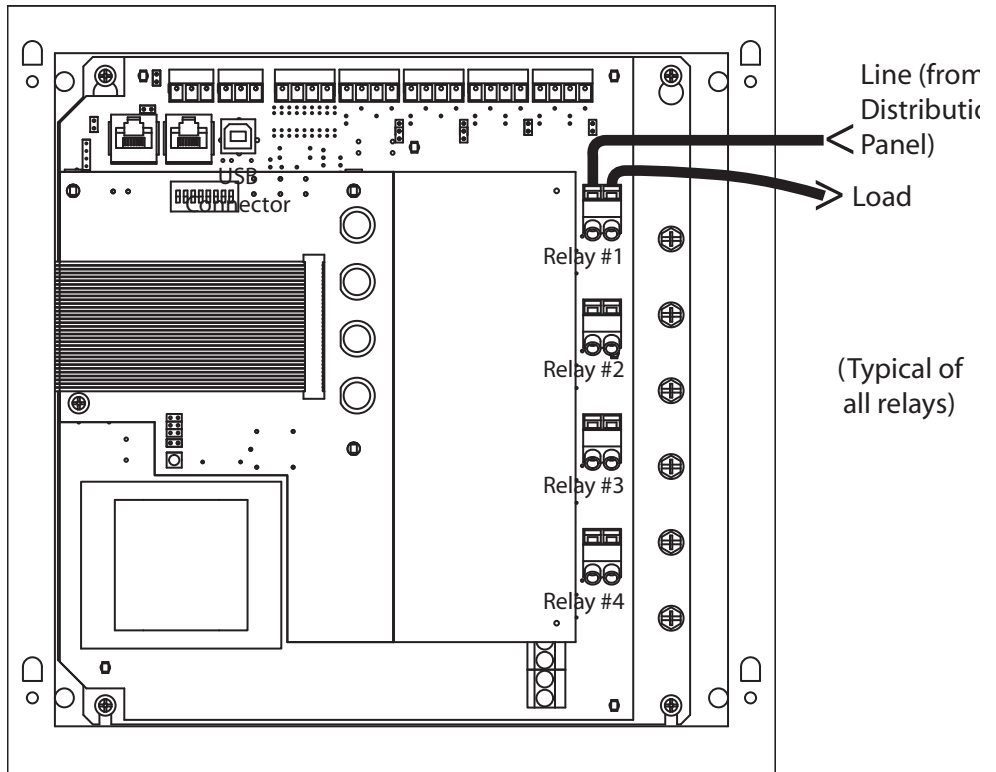

Wiring Diagram for 4 Relay Panels, 1-Pole Relay

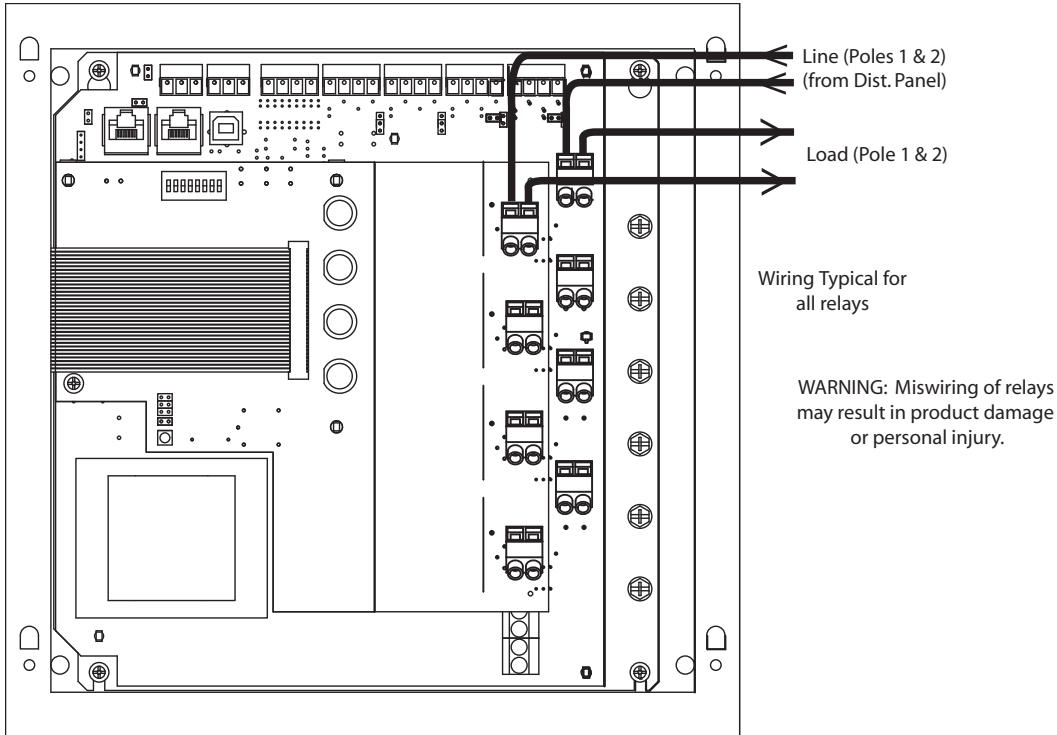

Wiring Diagram for 4 Relay Panel with 2-Pole Relay Card

Feed and Load Wiring, Line and Load Circuit Wiring

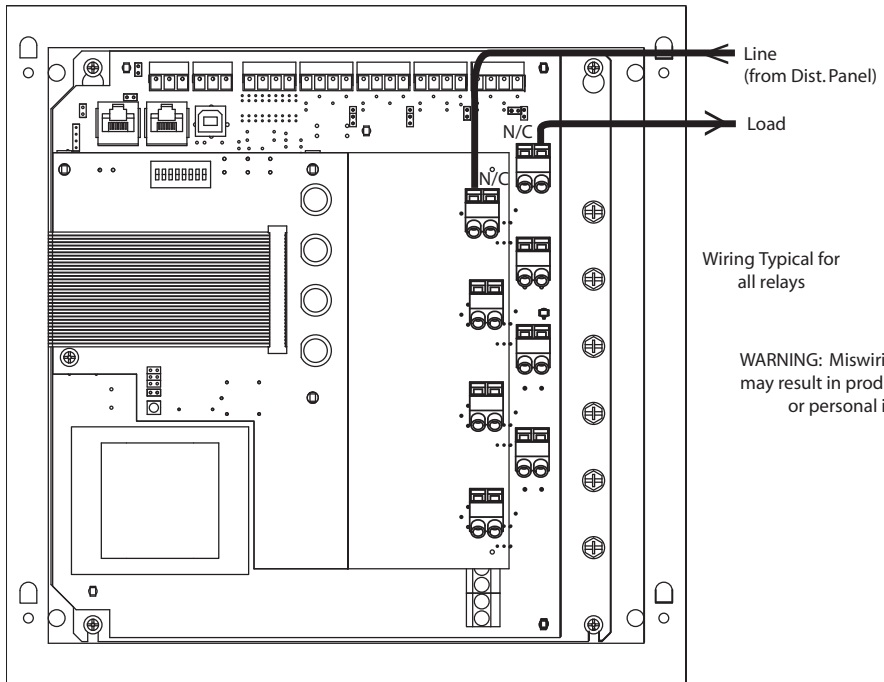

Wiring Diagram for 4 Relay Panel 347V Canadian Relay

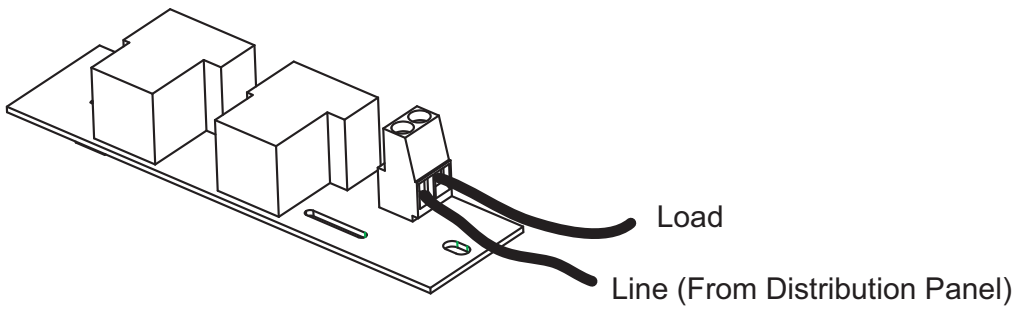

Wiring Diagram for Z-MAX (Standard) Relay Card

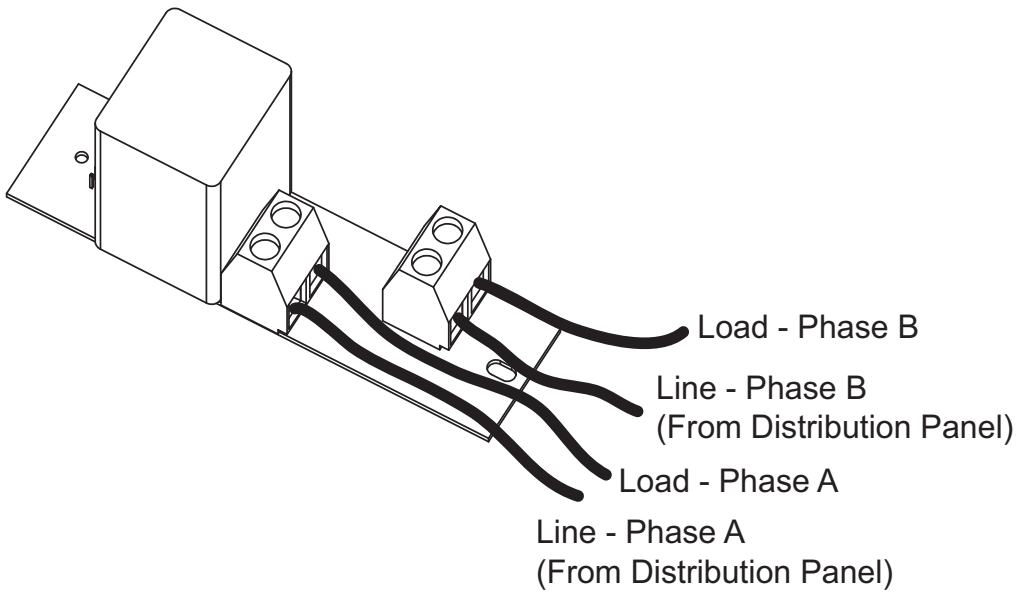

Wiring Diagram for 2-Pole Relay Card

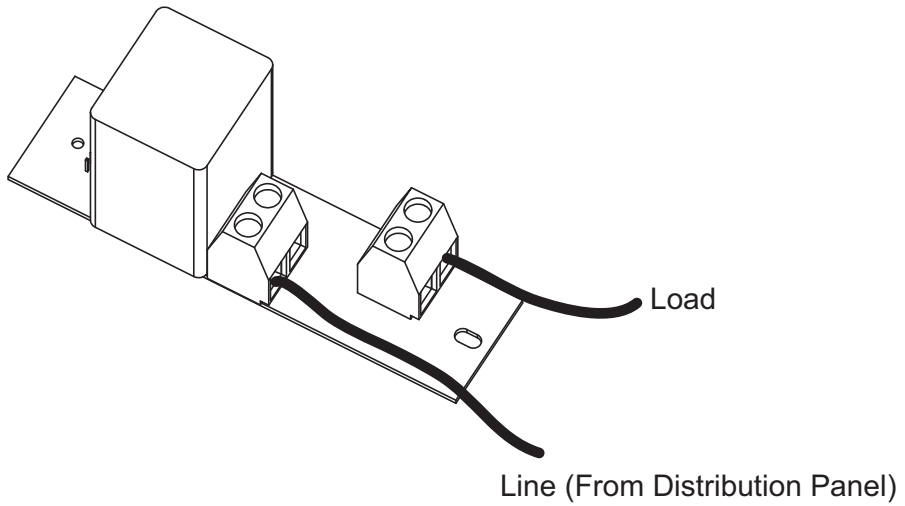

Wiring Diagram for 347 V Relay Card

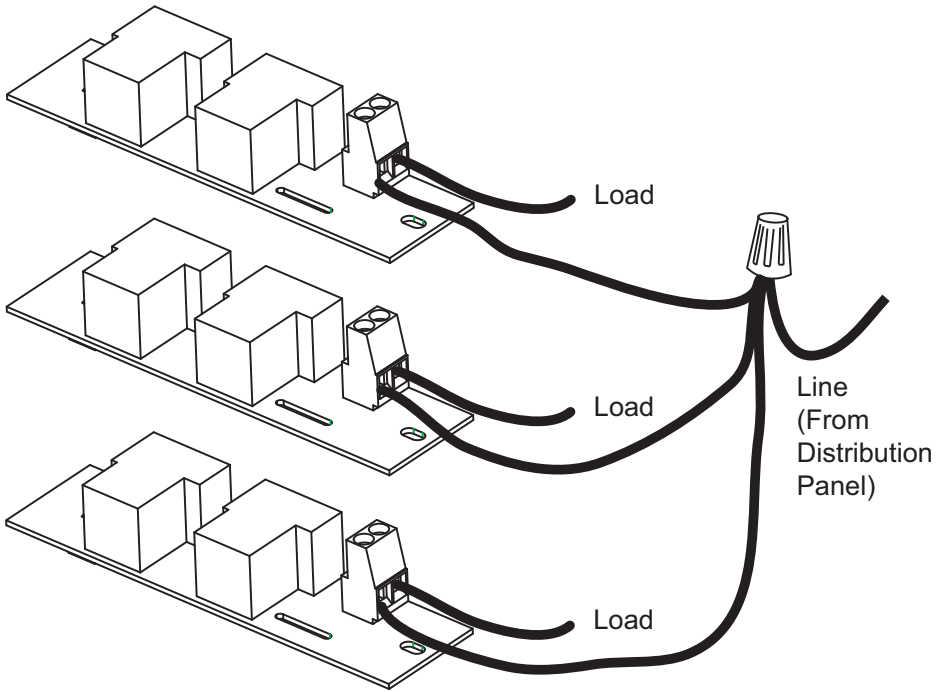

Wiring of Multiple Relays to Common Branch Circuit Breaker

Control Electronics Power Wiring

Your relay cabinet requires a specific power circuit for the control electronics. Leviton recommends that this power circuit be dedicated specifically and used only for power to the control electronics.

NOTE

If the control electronics must function during a power outage or other interruption, the control electronics power must be fed from a UPS, generator, or other guaranteed source.

To connect your relay cabinet's control electronics to power, please follow the following steps:

- Step 1:** Connect the relay cabinet to the circuit breaker panel using conduit
- Step 2:** Remove all debris
- Step 3:** Run a dedicated circuit from the circuit panel or distribution panel to the relay panel for the control electronics. Make sure the power is off at the breaker.
- Step 4:** Wire the circuit as shown below
- Step 5:** Connect the circuit ground wire to the relay cabinet
- Step 6:** Keep the circuit off until all wires are terminated, tested, and double checked

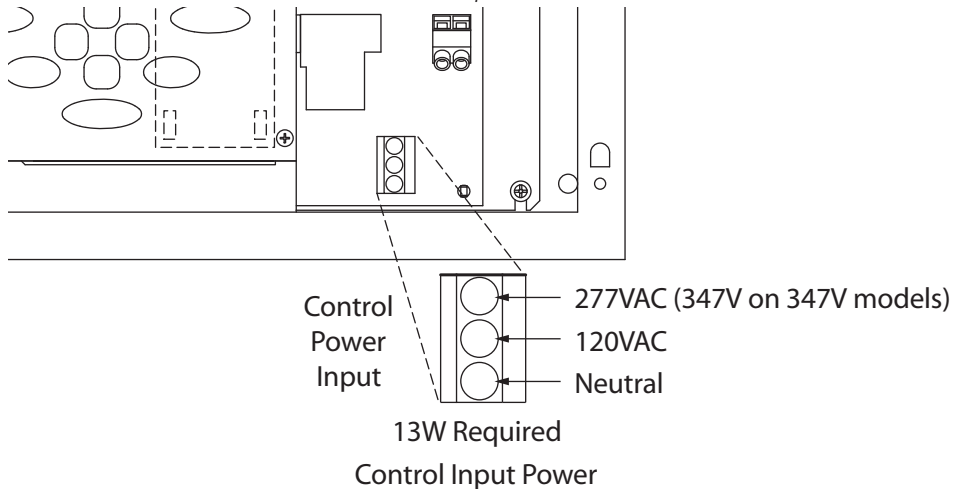

4 Relay Panel Control Electronics Power Wiring

Multi-Tap Transformer

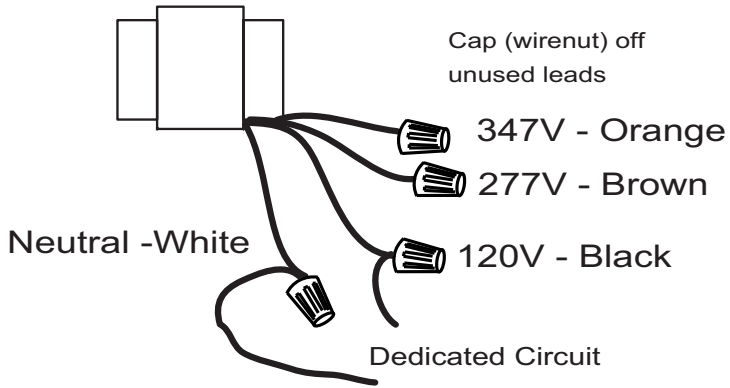

24 & 48 Relay Cabinets Control Electronics Power Wiring

Circuit Schedule

Relay/Circuit			Control			Load Circuits			
No.	Panel Breaker	Field Circuit	Luma-Net Channel	DMX Channel	Analog Input	Relay Type	Load Watts	Description	Group
1									
2									
3									
4									
5									
6									
7									
8									
9									
10									
11									
12									
13									
14									
15									
16									
17									
18									
19									
20									
21									
22									
23									
24									
25									
26									
27									
28									
29									
30									
31									
32									
33									
34									
35									
36									
37									
38									

WEB VERSION

Relay/Circuit			Control			Load Circuits			
No.	Panel Breaker	Field Circuit	Luma-Net Channel	DMX Channel	Analog Input	Relay Type	Load Watts	Notes/ Circuit Description	Group
29									
30									
31									
32									
33									
34									
35									
36									
37									
38									
39									
40									
41									
42									
43									
44									
45									
46									
47									
48									

Master/Remote Network Interconnection

Physically interconnecting your relay panels together on a master/slave network is easy. It requires only the use of category 5 or better network wire, with RJ-45 connectors on each end.

Please reference the illustrations below which show the connection locations for the Master/Slave network wiring for each panel type. Note that there are (2) receptacles, one to go to the "next" panel and one coming "from" the previous panel. It does not matter which one you use, so long as you only use the pair that is labeled "Master/Slave" or on some panels "CAN 1".

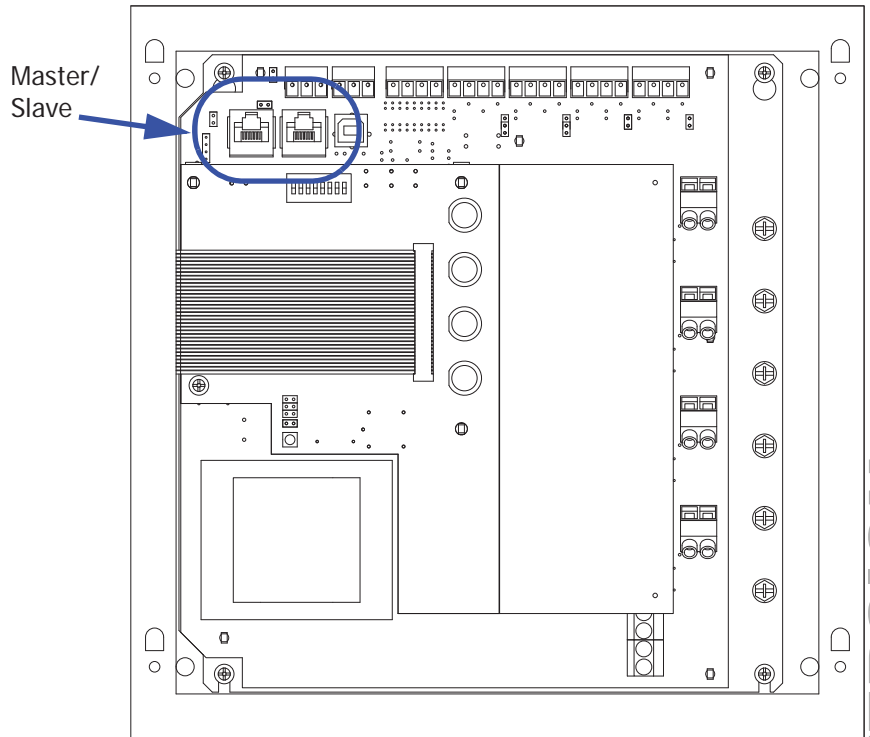

Master/Slave Connections, 4 Relay Cabinet

Switch Inputs and DMX Connector-
Wire Range #14 - #24 AWG
Torque 2 LB-IN

Luma-Net Connector
Wire Range #12 - #24 AWG
Torque 5 LB-IN

ANALOG/SWITCH INPUT/OUTPUTS TB 1-12*

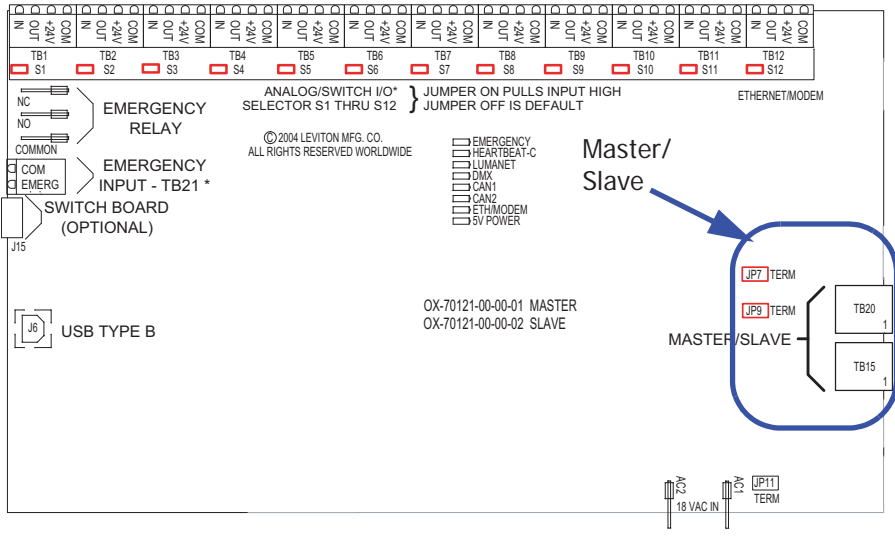

ALL OFF NORMAL ALL ON

Mater/Slave Connections, 24 & 48 Relay Panel

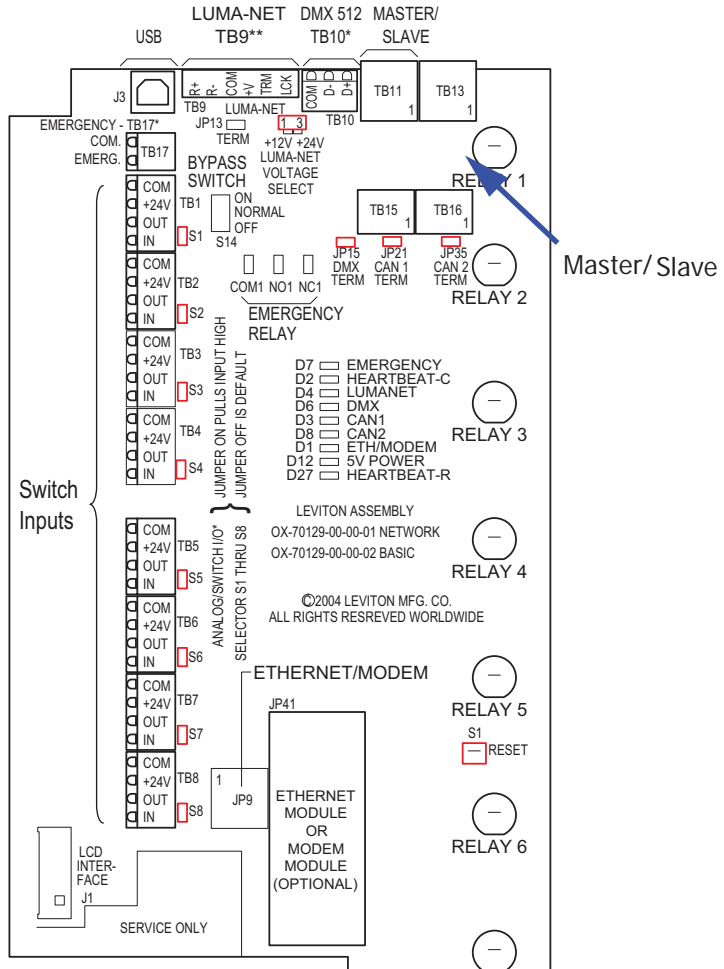

WEB VERSION

RJ-45 Pinout

There are two major standards for the pinout of RJ-45 connectors. These two standards are often referenced as TIA-568A & TIA-568B. Although either is acceptable so long as it is consistent throughout a project, Leviton recommends the use of only the TIA-568B standard. The only difference between the standards is what color wires terminate to each of the (8) RJ-45 pins. Per the TIA-568B standard, the pinout for your RJ-45 connectors are as follows:

TIA-568B Wiring Standard Chart		
Pin	Pair #	Color
1	2	Orange/White
2		Orange
3	3	Blue/white
4	1	Green
5		Green/white
6	3	Blue
7	4	Brown/White
8		Brown

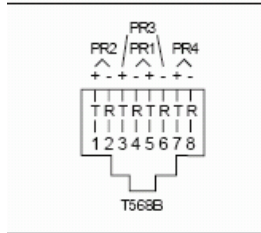

NOTE

Unlike some other wiring systems, Category 5 networking wiring requires that the connectors at both ends of the cable be wired the same.

NOTE

RJ-45 connectors must be "crimped" onto the end of your Category-5e cable in order to successfully make your connections. This requires a special tool made specifically for this purpose called an "RJ-45 Crimper" or other similar terminology. Always use one of these crimpers when making these connections. Read and understand the instruction by the crimpers manufacturer prior to use. Leviton offers a crimper as Leviton part number 47613-EZC.

Termination

All CAN based networks must be terminated at both ends. The Z-MAX Master/Slave network is no exception.

Each panel has a termination jumper. When a relay panel is the last panel on the run, it's termination jumper must be installed.

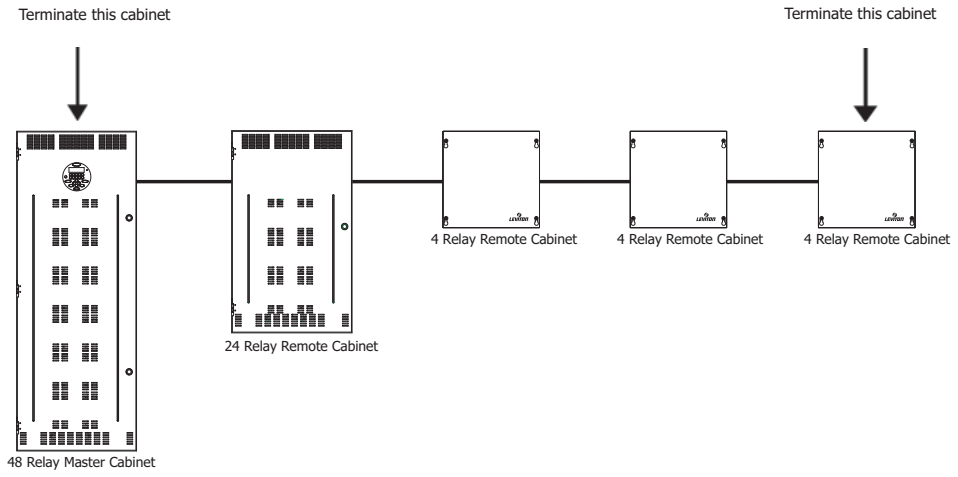

Cabinets requiring termination

How to Terminate Relay Cabinets

Step 1: Locate the termination jumper which corresponds to the Master/Slave communication receptacles on your relay panel

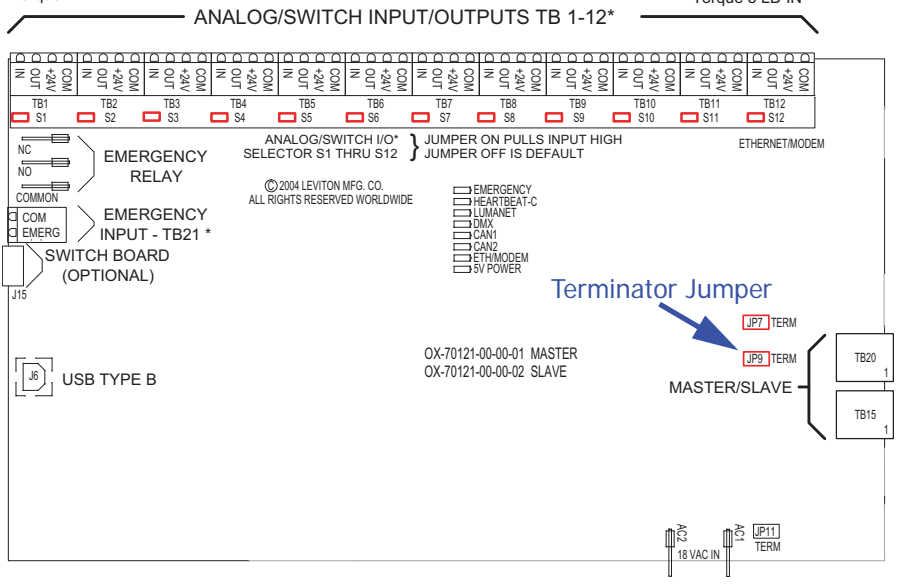

Step 2: Install the jumper. Your cabinet is now terminated.

Low Voltage Control Wiring

NOTE

The use of low voltage control inputs on Remote Relay panels is only available in software release 1.40 and above for both the master and slave cabinets. If you plan to use this feature, please make sure that all cabinets have been upgraded. Additionally, if your cabinet was shipped before 1.40 was released, the firmware may need to be updated. If you suspect this is the case, please contact our technical services department at (800)959-6004.

Once the power wiring has been completed, control wiring can be addressed. Control wiring can be divided into two categories: analog and digital. When dealing with remote relay panels, only the analog control inputs can be used.

The remote relay panels can accept the following control signals on any of its inputs:

- Low Voltage inputs (Switches)
- Photocells
- Occupancy Sensors
- Dry Contacts
- Analog 0-10VDC Inputs

The specific wiring requirements for each input type is discussed on the following pages.

NOTE

Each product (and in some cases each model of a product) has a slightly different layout at the terminals blocks. The specific functions of each terminal is labeled on the circuit board adjacent to the terminal blocks. When wiring the inputs, verify that you are connecting the correct wire to the correct terminal based on function even if it deviates from that shown in this documentation. Contact our technical services department with any undocumented questions.

Control Wiring Termination

This section gives instructions for terminating all types of low voltage inputs.

- Leviton recommends minimum 18AWG stranded wire for all low voltage wiring
- Terminate all control wiring directly to the terminal blocks on the printed circuit board. Use a small 1/8-in. flat screwdriver on these terminals
- Terminal blocks are 2-part terminals and can be removed for ease of termination. When reinstalling them make sure they are plugged in the correct direction for the way they were wired
- On the 4 relay remote panel, models re4sd-*, inputs #5 & #6, labeled photocell and occupancy sensors can not be used
- All control wiring shall be considered Class 2
- Use control wire type and size as specified below:

Connector Type	Wire Size and type	Torque
Switch Inputs	14-18 AWG, Stranded	2 in.-lb.

Control Wire Type and Size

Input Trigger - What determines an "ON"

Each of the low voltage inputs can be triggered by either the supply of voltage or a connection to common. When voltage is supplied to an input indicating a change of state, we call this "pulling up the input" or "active high." When a connection to common triggers the input, causes a change of state, we call this "pulling down the input" or "active low."

By default, all inputs are active high (that is receiving voltage to trigger). Active High inputs must not exceed a nominal +24VDC

and must be above +9vdc. Active Low inputs must connect to the same common at the same potential as the cabinet.

To change from an active high input to an active low input, the polarity jumper must change position. There are several illustrations which show the location of these jumpers. Additionally, when configuring the input, it must be configured as an "Active Low" input. Reference the section in this user guide which deals with the configuration of low voltage discreet inputs.

Input Power Requirements

The relay cabinet has a finite amount of power which it can supply to connected devices. This topic is discussed in detail in the following section "Power Considerations for Control Systems" Please make sure that you do not exceed the amount of available power, or damage to your relay cabinet or connected devices may occur.

General Requirements for Connecting any Device to Low Voltage Inputs

- Step 1:** Connect leads per wiring diagram as illustrated in the figures on the following pages
- Step 2:** Twist strands of each lead tightly (making sure that there are no stray strands) and push firmly into appropriate plug connector location.
- Step 3:** Tighten the screws on the plug connector—making sure that no bare conductor is showing.
- Step 4:** Plug the connector back onto the control module with the screws facing the front and the wires coming out of the connector toward the top of the cabinet.

Low Voltage Input Terminals & Connections

The next several drawings show the location of inputs in the various cabinet types.

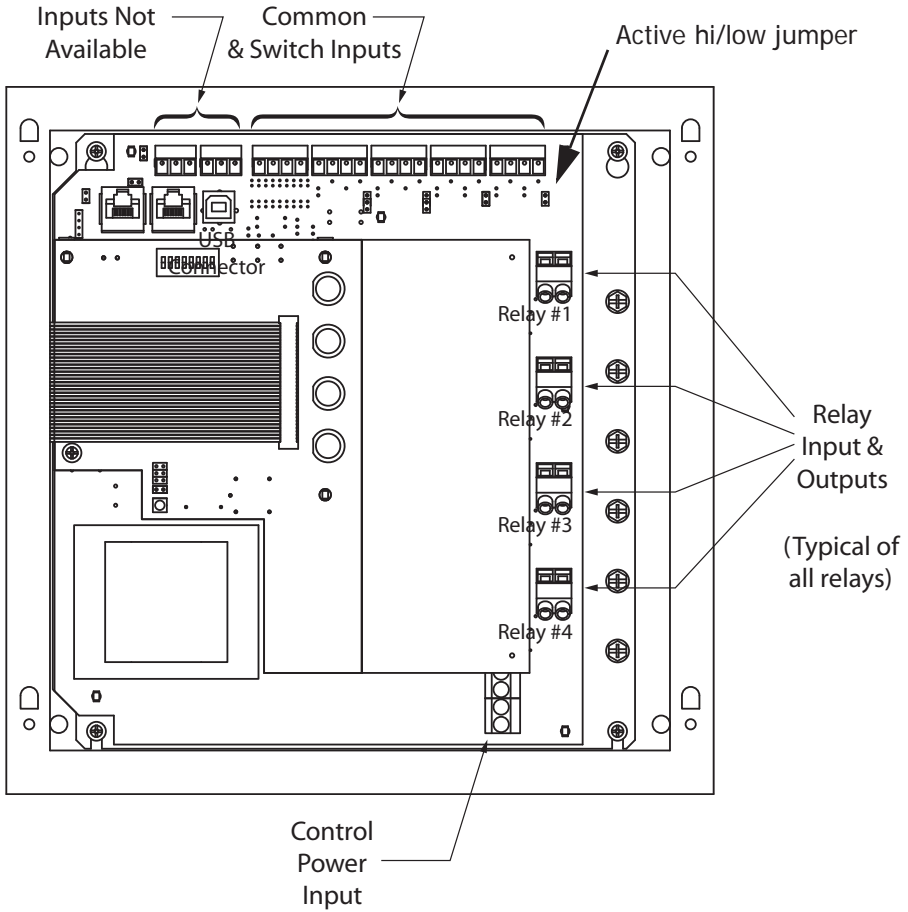

Low Voltage Input Locations, 4 relay remote relay cabinets

Jumper Locations (typical) for changing active high/active low

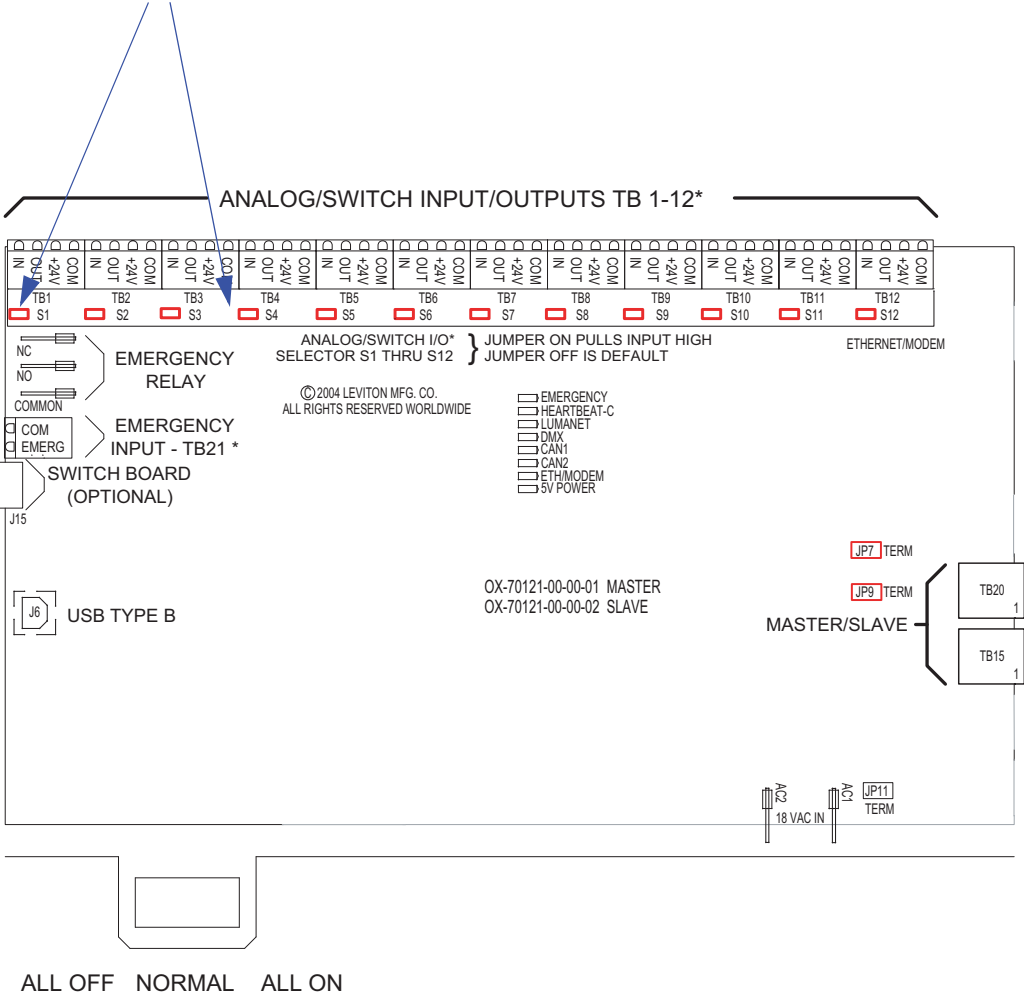

Low Voltage Input Locations, 24 & 48 remote relay cabinets

WEB VERSION

Connecting Low Voltage Switches

Z-MAX relay panels support a variety of low voltage switch types such as:

- Momentary - provides momentary contacts, triggering alternating on/off actions
- Maintained - triggers On action when connection is made, Off action when removed
- Momentary On/Off with On & Off terminals provided - provides momentary connection to the "On" terminal to trigger an on action, momentary connection to the "Off". Used with single pole double throw center off (SPDT-CO) switches
- Momentary On/Off with only "IN" or "ON" terminal - used with 2 pole center off switches and must be used in conjunction with either the part number #rac00-2sc or #rac00-2sb switch input kits to convert from a 1 terminal to a 2 terminal input

Each Input has a multi-position screw terminal with various positions. The terminal can be pulled off its base for ease of wiring. Two possible pinouts are shown.

Terminal layout common to 4

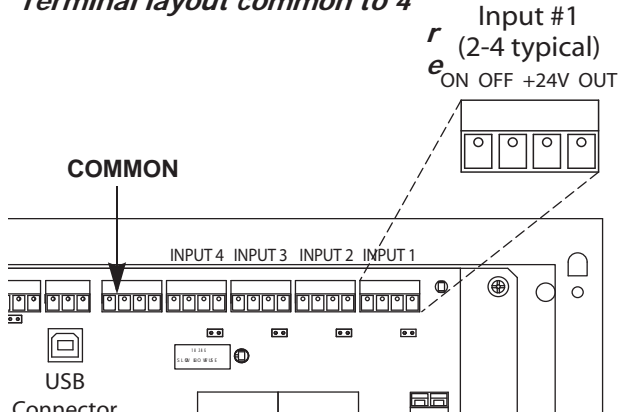

24 & 48 relay cabinets

Terminal layout common to

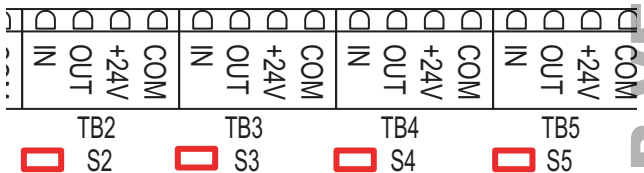

WEB VERSION

Please remember to verify the function of each pin as labeled on the product with the device being wired to ensure that it is wired correctly.

Regardless of the pinout of your particular product, the common designations for terminals are as follows:

Pin Label	Function
+24V	Supplies +24Vdc power to devices, usually unregulated
COM	Connection to DC Common of the cabinet
IN	Switch Input or signal from device. Usually expecting +V to trigger.
OUT	Used for connection to device LED indicating on/off state of that input. Connects to common when on, floats when off. (Max 0.04A)
LED	Used for connection to device LED indicating on/off state of that input. Connects to common when on, "floats" when off. (Max 0.04A)
ON	Usually can be configured identically to the IN terminal but can be configured as Momentary ON input only
OFF	Momentary OFF input only

By default the "IN" or the "ON" terminal is expecting +V to trigger as would be typical with many styles of low voltage switches. If a connection to common is required, it requires some jumper and software reconfiguraiton. For more information on this topic, please reference the discussion on input triggers found on page 52.

Connecting Low Voltage Switch

Step 1: Strip each wire from your device and tightly twist the wires together

- Step 2:** Insert the wires from the device into the connector on the relay cabinet in the appropriate location
- Step 3:** Tighten the terminal screw, and repeat for all wires from the device
- Step 4:** Plug the terminal block back into the cabinet with the screws facing towards you and the wires exiting towards the side or top of the cabinet. Alternatively, the connector can be inserted with the screws parallel to the circuit board and the wires exiting towards you
- Step 5:** Verify that the wires land on the correct terminals

Occupancy Sensors

One of the control input types which your relay cabinet can accept is Occupancy Sensors. When using an occupancy sensor, the cabinet is expecting a DC voltage, between +9V & +24V to trigger an occupied state, or a floating input to indicate an unoccupied state. The specific function of what happens in each of these states is set via software configuration. This section only deals with connecting your Occupancy sensor to your relay cabinet.

Occupancy Sensor Wiring

Step 1: Connect leads per wiring diagram below.

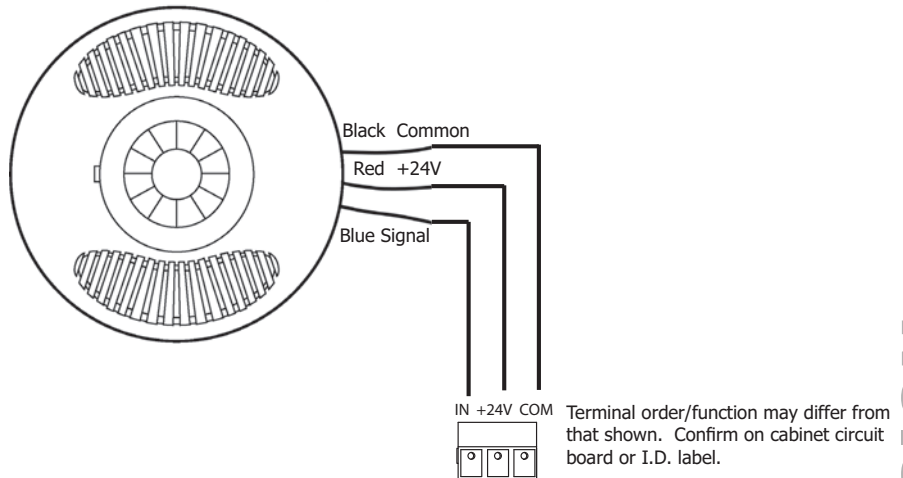

Occupancy Sensor Termination using Dedicated Occ Sensor Terminal

- Step 2:** Twist strands of each lead tightly (making sure that there are no stray strands) and push firmly into appropriate plug connector location.
- Step 3:** Tighten the screws on the plug connector making sure that no bare conductor is showing.
- Step 4:** Plug the connector back onto the control module.
- Step 5:** Verify that the wires from the Occupancy Sensors are connected to the correct terminals in the cabinet.

Photocells

The relay cabinet is capable of supporting the following types of photocells:

- Switched Photocell (On/Off, trigger point set at photocell)
- 0-10V Photocell

The configuration and behavior of your photocell is set via software and discussed elsewhere. This section only covers installation.

Photocell Wiring

Step 1: Connect leads per wiring diagram as illustrated in one of the figures below:

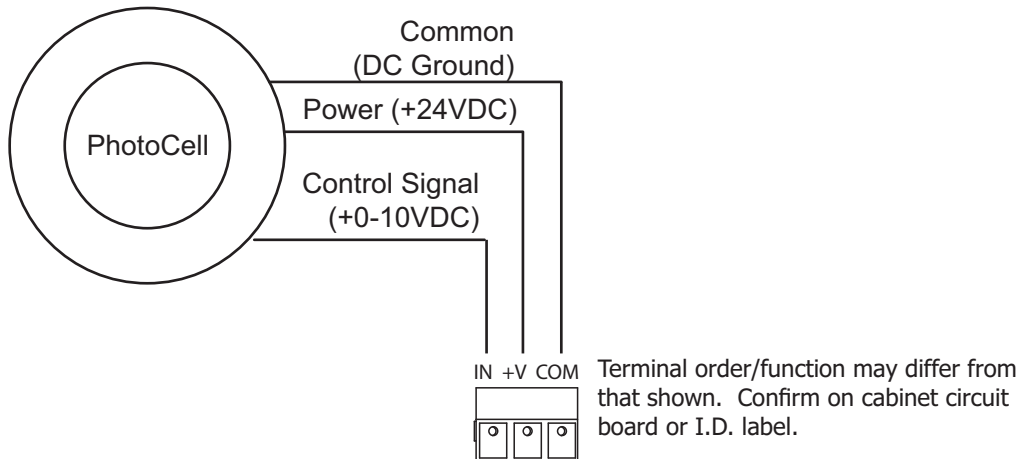

0-10VDC Photocell Wiring

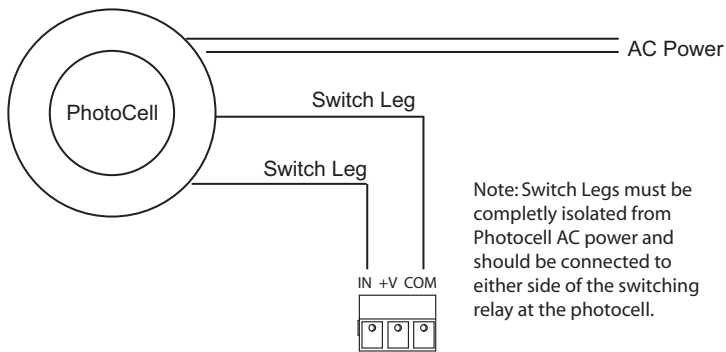

Note: If your switching photocell requires +24VDC power, this power can be sourced from the cabinet just like a 0-10VDC photocell. The switch legs should still be between COM & IN terminals

Note: Switch Legs must be completely isolated from Photocell AC power and should be connected to either side of the switching relay at the photocell.

Switching Photocell

- Step 2:** Twist strands of each lead tightly (making sure that there are no stray strands) and push firmly into appropriate plug connector location.
- Step 3:** Tighten the screws on the plug connector making sure that no bare conductor is showing.
- Step 4:** Plug the connector back onto the control module with the screws facing the front and the wires coming out of the connector towards the top of the cabinet.
- Step 5:** If using a switched photocell, make sure that the jumper below the connector is in the "ON" position.

Wiring with an External Power Supply

When needed, an external class 2 power supply can be used to supply power to Low Voltage devices connected to the low voltage inputs. When this is required, wire the system by following the diagram below.

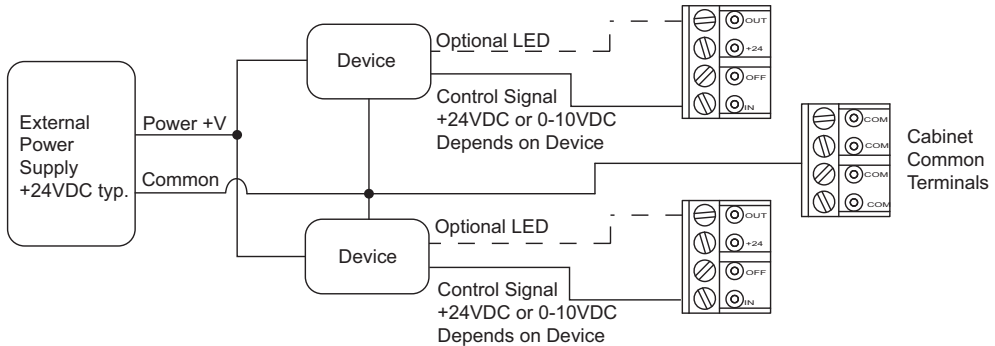

Using an External Power Supply

You must consider the following when using an external power supply:

- Use the external supply for +24V (or other required device) and common to the devices
- Any return from a device which is connected to a switch input must not exceed +24VDC.
- Connect the common from the external supply to the common of any switch input
- Use the device output (Control Signal) to the "IN" terminal of the respective switch input
- Use the "OUT" terminal from the switch input for device feedback, like a low voltage switch LED
- DO NOT connect the +V of the external supply to any of the +24V terminals of the relay panel. This will nullify the Class 2 rating of the power run.

Power Considerations for Control Systems

The control system should be carefully planned to take these important issues into consideration:

- Power Supply for connected devices
- Wire Size for Power Runs

On systems where full factory drawings have been provided, our Applications Engineering department has already managed these calculations for you so you need only follow the instructions on the system drawings. However, on any installation where factory drawings were not provided, the information contained within this guide must be followed to ensure that all of your devices operate properly and without failures or complete in-operability.

NOTE

This chapter contains information which applies to many Leviton products and is not necessarily limited to the product which is primarily included in this manual. There may be information in this chapter which is not relevant to your particular installation. If you have questions about ANY information contained herein, please immediately contact our Technical Services Department prior to proceeding with installation.

Terminology

Please review these definitions which are used throughout this chapter:

- *Power Supply* or *Supply* - references a device which supplies power to other devices

- *Power Control Device (PCD)* - refers to a device which controls power. Examples of Devices in the Leviton product line which control power are dimming racks, relay panels, A-2000, i-series e, Z-MAX, etc. Generally PCD's also supply a certain amount of power to connected low voltage control devices
- *Control Devices or Low Voltage Control Devices or Device* - these terms all refer to control devices which connect to a Power Control Device (PCD). These devices could be simple low voltage switches, Occupancy Sensors, or D8000 control stations
- *Luma-Net* - is one of our network lighting control protocols. Luma-Net is an RS-485 based control protocol used by D8000 & D4200 control devices. Many of our PCD (Power Control Device) products have a direct data connection for a Luma-Net device. All Luma-Net Control Devices require power in one form or another. This power generally accompanies the data wires
- *Unit Load* - (1) Unit load is defined as 25mA, or 0.025A. It is an arbitrary definition by Leviton and was created to simplify power calculations

Power Requirements & Maximum Run Length

Each Control Device used in your system has a different load (draw) and each PCD can support a different total load (supply.) The steps for determining the total load of your network and verifying that the supply is sufficient are simple--or at least logical:

- Step 1:** Determine the maximum available current of your supply, be it a PCD or other Power Supply. Convert this to the maximum number of Unit Loads if necessary.
- Step 2:** Sum the required load of each Control Device, expressed in unit loads
- Step 3:** Verify that the Sum from Step 2 \leq the maximum available power from your supply in Step 1.
 - If this verification fails, the Sum of required loads is $>$ than the available supply, either use an external power supply or reduce the number of control devices. Or, contact our Technical Services department for help.

NOTE

One Unit Load = 25mA = .025A

$$\begin{array}{|c|} \hline \text{Control Station A Unit Load} \\ \hline \mathbf{X} \\ \hline \text{Quantity of Station A's attached} \\ \hline \end{array}
 +
 \begin{array}{|c|} \hline \text{Control Station B Unit Load} \\ \hline \mathbf{X} \\ \hline \text{Quantity of Station B's attached} \\ \hline \end{array}
 +
 \begin{array}{|c|} \hline \text{Same formula} \\ \hline \text{for any other attached} \\ \hline \text{control Station} \\ \hline \end{array}
 <
 \begin{array}{|c|} \hline \text{Power Supply's} \\ \hline \text{Available Unit Load} \\ \hline \end{array}$$

Load Rating Verification Formula

Power Control Devices - Available Supply Current

The Z-MAX cabinets are designed to be able to power external control loads from the internal power supply. See the table below for the available power from each cabinet.

Power Control Device (PCD)	Maximum # of Unit Loads	Supply (VDC)	Power Control Device (PCD)	Maximum # of Unit Loads	Supply (VDC)
a-2000D, 12 Circuit, Standard Power Supply	52	12VDC	Z-MAX 8 Cabinet	20	24 VDC
a-2000D, 18 Circuit, 277V, Standard Power Supply	49	12VDC	Z-MAX 24 Cabinet (Master or Slave)	20	24 VDC
a-2000D, 24 Circuit Standard Power Supply	46	12VDC	Z-MAX 48 Cabinet (Master or Slave)	20	24 VDC
a-2000D, 12 Circuit, Large Power Supply	120	12VDC	Z-MAX Switch Input Board (accessory to Z-MAX 24 & 48 size Cabinets)	20	24 VDC
a-2000D, 18 Circuit, 277V, Large Power Supply	117	12VDC	EZ-MAX	6	24 VDC
a-2000D, 24 Circuit Large Power Supply	114	12VDC	RRP - Z-MAX Remote Relay Panel	6	24 VDC
NPC – XP	49	12-24 VDC	i Series e (all Racks)		

WEB VERSION

Power Control Device (PCD)	Maximum # of Unit Loads	Supply (VDC)	Power Control Device (PCD)	Maximum # of Unit Loads	Supply (VDC)
NPC – DHV	N/A	N/A			
NPC – DLR	49	12-24 VDC			

Power Supply Maximum Unit Loads

NOTE The sum of all devices connected to all power output terminals can not exceed the Maximum number of Unit Loads available in the PCD or supply.

Control Devices	Unit Load @12VDC	Unit Load @24VDC	Station Type	Unit Load @ 12VDC	Unit Load @ 24VDC
D4200 LCD	5	2	Z-MAX Digital Switch, 1 Button	N/A	0.6
D4200 Entry (Button),	2	1	Z-MAX Digital Switch, 2 Buttons	N/A	0.8
D4200 Room Combine Station	3	1	Z-AX Digital Switch, 3 Buttons	N/A	1.0
D4200 Remote I/R	2	1	Z-MAX Digital Sw., 4 Buttons	N/A	1.1
Luma-Net Hub	6	3	Z-MAX Digital Switch, 5 Button	N/A	1.3
D8000 LCD	3	2	Z-MAX Digital Switch, 6 Button	N/A	1.0
D8000 Entry (Button)	2	1	Z-MAX Digital Switch, 8 Button	N/A	1.1
D8000 Slider	2	1	Z-MAX Digital Sw., 10 Button	N/A	1.3
D8000 Key switch	1	1	1 Button Low Voltage Switch	N/A	0.6
D8000 I.O Port	2	1	2 Button Low Voltage Switch	N/A	0.9
D8000 Combine/ Closure (Advanced)	11	10	3 Button Low Voltage Switch	N/A	1.2
Infrared Only Occ Sensor	N/A	1.2	4 Button Low Voltage Switch	N/A	1.5
Ultrasonic Only Occ. Sensor	N/A	1.2	5 Button Low Voltage Switch	N/A	1.8
Multi-tech Occ Sensor	N/A	1.2	6 Button Low Voltage Switch	N/A	2.1

Control Devices	Unit Load @12VDC	Unit Load @24VDC	Station Type	Unit Load @ 12VDC	Unit Load @ 24VDC
Ultrasonic 2-Way Occ. Sensor	N/A	1.4	8 Button Low Voltage Switch	N/A	2.7
Multi-tech 2-Way Occ. Sensor	N/A	1.4	10 Button Low Voltage Switch	N/A	3.3
Photocell, odc0p-00w			Photocell, pcatr-000		
Photocell, pcind-000			-		
Photocell, pcout-000			-		
Photocell, pcsky-000			-		

Control Device Loads

Power Wire - Run Length

The maximum total run length of each segment is a function of the total number of unit loads. A run becomes too long when the voltage drop, due to wire size and run length, increases to a point where the station does not have sufficient voltage to operate. The maximum run length, in feet, based on the total number of unit loads is shown below:

NOTE

(2) Tables are provided, (1) @ 12VDC and (1) at 24VDC. Make sure that you use the correct table!

	14 AWG (Feet)	12 AWG (Feet)	10 AWG (Feet)
10 Unit Loads	1905	3000	4800
20 Unit Loads	950	1500	2400
30 Unit Loads	630	1000	1600
40 Unit Loads	475	750	1200
50 Unit Loads	380	600	960
60 Unit Loads	315	500	800
70 Unit Loads	270	425	685
80 Unit Loads	235	375	600
90 Unit Loads	210	330	530
100 Unit Loads	190	300	480
110 Unit Loads	170	270	435
120 Unit Loads	155	250	400

Wire Size vs. Length of Runs - Power Wiring @12 VDC

Configuration

All of the functional configuration of your relay cabinet is performed at the master control module. However, prior to the master control module being able to address the remote relay cabinets, there are two primary configuration steps which must occur:

- Set the Starting Relay Number
- Set the starting relay & remote input number

Before we get into the specific configuration of the above items, please review the basic rules of Master/Slave networks and network topology on page page 21. The rules expressed in that section are critical to the successful operation of your network.

Out of the Box Configuration

The steps required to successfully configure your remote relay panel are as follows:

- Step 1:** Configure the Slave Cabinets
- Step 2:** Configure the Master Cabinet for Master/Slave
- Step 3:** Verify Network Communication
- Step 4:** Configure relay functionality at the Master

Remote/Slave Cabinet Configuration

The remote relay cabinets must be configured with their starting relay number. On some of the relay cabinets this is performed using a dipswitch on the circuit board inside the cabinet, on other relay cabinets this configuration must be performed from a PC connected via USB.

Comments & Examples on Relay Numbering

Please find a discussion with examples of relay numbering found on page 23. This information may be helpful when configuring your relay panels.

Configuration of Remote Relay Cabinets with Dipswitches

Locate the 8 position dipswitch and set the "MRN" code which corresponds to the starting relay number. The MRN code and corresponding starting relay numbers can be found in the table on the next page. The MRN code equals the sum of all the values "enabled" by the dipswitch.

Table of MRN Codes & Starting Relay Number

MRN Code	Start Relay Number
1	1
2	5
3	9
4	13
5	17
6	21
7	25
8	29
9	33
10	37
11	41
12	45
13	49
14	53
15	57
16	61
17	65
18	69
19	73
20	77
21	81
22	85
23	89
24	93

To Set the MRN Code:

Step 1: Choose the MRN code that corresponds to your starting relay code as shown in the Table of MRN Codes & Starting Relay Number on page 77.

Step 2: Enter the MRN code into the dipswitch by adding the value of each lever in the "On" position. The values of the levers are as follows:

- $1 = 1$
- $2 = 2$
- $3 = 4$
- $4 = 8$
- $5 = 16$
- $6 = 32$
- $7 = 64$
- $8 = 128$

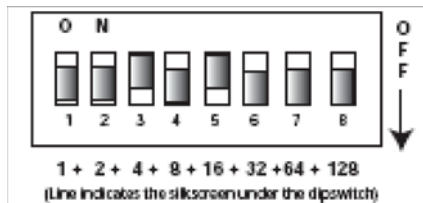

For example, if you wanted to set the starting relay number to 77, you would reference from the starting relay number to MRN code chart that

Starting Relay Number 77 = MRN Code 20

From that you then would deduce that you need Lever 3 & 5 in the on position because $16 + 4$, the values associated with levers 3 & 5 sum to 20, resulting in a starting relay number of 77.

Configuration of Remote Relay Cabinets without Dipswitches or via USB

Remote relay cabinets that do not have dipswitches for setting the starting relay number you must be configured via USB. The instructions contained in this part of the manual assume that you already have a successful connection between your PC and your relay cabinet. For instructions connecting your PC to your relay

cabinet, please reference the instructions contained at our website, www.leviton.com and in your master control panel user guide. Additionally, for this purpose, your PC requires additional software and drivers which must be downloaded from our website.

Once connected to the relay panel via USB and you have the terminal program open at the Z-MAX prompt, there are several settings which can be set to affect operation of master/slave cabinets. From the terminal prompt, the command 'help' (without quotes) can be used at anytime to list out all commands and their syntax. Note that not all settings are applicable to remote panels.

- MRN Code - sets the MRN code determining the starting relay for this panel. This is usually the only option you're going to need to set for Remote relay panels. A table of MRN codes and their corresponding starting relay number can be found on page 77.
- MRE Code - The setting is only used in Master panel configurations to set the number of external relays. On slave cabinets this should always be set to 0, the default setting
- MRI Code - Set the number of local (or internal) relays to the cabinet. This should be set to the maximum number of relay module positions in the cabinet.

Configuration of Master Control Panel

Enable Master/Slave Communication

Configuration of the master control panel can be performed from the LCD. There are three settings which need to be set on the Master Control panels to enable Master/Slave Communication

- Remote Relay (RMT RLY) Setting, to enable Master/Slave communication
- Number of Local Relays (LOC RELAY) if a setting other than the default of (48) is required
- Set the Remote Node ID of the Mater panel to indicate that it is a master (MAS).

Enabling Master/Slave Communication

Step 1: Press the **MENU** button to enter the menu structure

Step 2: Use the arrow keys and the **SELECT/SAVE** key to navigate to Configuration, System Setup, then Global Defaults

Step 3: Using the arrow keys, find the menu below:

G L O B A L	D E F A U L T S	
R E M O T	N O D E I D	O F F

Step 4: Press **SELECT/SAVE** until the OFF is blinking, then use the arrow keys to set it to MAS

G L O B A L	D E F A U L T S	
R E M O T	N O D E I D	M A S

Step 5: Press **SELECT/SAVE** to save the setting

NOTE

If it is desired to have a Master relay panel operate as a Slave panel, set the RMT RLY to an MRN code from the preceding table which will define both this panel as a Remote panel and set the starting relay number.

Setting the Total number of Remote Relays

The total number of remote relays controlled by this master must be set so that the master cabinet knows how many relays it needs to address. To set this value:

Step 1: Press the **MENU** button to enter the menu structure

Step 2: Use the arrow keys and the **SELECT/SAVE** key to navigate to Configuration, System Setup, then Global Defaults

Step 3: Using the arrow keys, find the menu below:

```
GLOBAL  DEFAULTS
REMOT  RELAYS  OFF
```

Step 4: Press **SELECT/SAVE** until the OFF is blinking, then use the arrow keys or numbers to set it to enter the total number of relays in all remote relay cabinets. If we were only controlling one 24 remote cabinet and one 4 relay remote cabinet, this value would be 28.

```
GLOBAL  DEFAULTS
REMOT  RELAYS  28
```

Step 5: Press **SELECT/SAVE** to save the setting

Enabling Remote Discrete Inputs

If you intend to have switches or other inputs (discrete) land at the remote relay panels yet to be configured from the master control panel, you must enable the receipt by the master panel of these messages. To enable remote discrete inputs, please perform the following steps:

NOTE

The use of low voltage control inputs on Remote Relay panels is only available in software release 1.40 and above for both the master and slave cabinets. If you plan to use this feature, please make sure that all cabinets have been upgraded. Additionally, if your cabinet was shipped before 1.40 was released, the firmware may need to be updated. If you suspect this is the case, please contact our technical services department at (800)959-6004.

Step 1: Press the **MENU** button to enter the menu structure

Step 2: Use the arrow keys and the **SELECT/SAVE** key to navigate to Configuration, System Setup, then Global Defaults

Step 3: Using the arrow keys, find the menu below:

G	L	O	B	A	L		D	E	F	A	U	L	T	S	
R	M	T		D	I	S	C	R	E	T	E		O	F	F

Step 4: Press **SELECT/SAVE** until the OFF is blinking, then use the arrow keys or numbers to change it to ON.

G	L	O	B	A	L		D	E	F	A	U	L	T	S
R	M	T		D	I	S	C	R	E	T	E		O	N

Step 5: Press **SELECT/SAVE** to save the setting

Communication Verification

Once all setup has been performed, and with the system powered up, verify that the Master & Remote cabinets have successfully "linked" to each other and are in communication with each other. To perform this validation, open the panels and look at the diagnostic LED's. Depending on the panel type, the location of these LED's may vary. Look for the LED labeled "Master/Slave" or "CAN". The status of this LED could be as follows:

- Blinking - Congratulations, cabinets are communicating successfully
- Off - Communication is not enabled. Check the Remote Node ID setting. (See page 80)
- On Solid - Addressing Conflict or other communication error. Verify configuration of all master and remote panels.

Conclusion

Once power circuits and low voltage inputs have been connected, and communication between the remote panels and their master have been verified, this part of the setup is complete.

The master control panel now has control over all inputs and relays. The relays act as an extension of the master relays and

the inputs act as an extension of the master inputs. To complete the functional programming of your system, please reference your Z-MAX User's guide which details the remainder of the required programming.

Warranty Information

Limited Warranty

Leviton Manufacturing Co Inc. warrants the products represented in this manual to be free of material and workmanship defects for a period of ten years after system acceptance or ten years after shipment from Leviton, whichever comes first.

This Warranty is limited to repair or replacement of defective equipment returned Freight Pre-Paid to Leviton Manufacturing at 20497 SW Teton Ave., Tualatin, Oregon 97062, USA. User shall call 1-800-959-6004 and request a return authorization number to mark on the outside of the returning carton, to assure that the returned material will be properly received at Leviton.

All equipment shipped back to Leviton must be carefully and properly packed to avoid shipping damage. Replacements or repaired equipment will be returned to sender freight prepaid, F.O.B. factory. Leviton is not responsible for removing or replacing equipment on the job site, and will not honor charges for such work. Leviton will not be responsible for any loss of use time or subsequent damages should any of the equipment fail during the warranty period, but agrees only to repair or replace defective equipment returned to its plant in Tualatin, Oregon.

This Warranty is void on any product that has been improperly installed, overloaded, short circuited, abused, or altered in any manner. Neither the seller nor Leviton shall be liable for any injury, loss or damage, direct or consequential arising out of the use of or inability to use the equipment. This Warranty does not cover lamps, ballasts, and other equipment which is supplied or warranted directly to the user by their manufacturer. Leviton makes no warranty as to the Fitness for Purpose or other implied Warranties.



Leviton Lighting Management Systems Division Headquarters
20497 SW Teton Avenue, Tualatin, OR 97062
Customer Service Telephone: 1-800-736-6682 • FAX: 1-503-404-5600
Tech Line: 1-800-959-6004

Leviton Manufacturing Co., Inc.
59-25 Little Neck Parkway, Little Neck, NY 11362-2591
Telephone: 1-800-323-8920 • FAX: 1-800-832-9538

Visit Leviton's Web site at <http://www.leviton.com>

© 2005 Leviton Manufacturing Co., Inc. All Rights Reserved

Specifications and Pricing Subject to Change at any time without notice

PK-93194-10-00-0A

WEB VERSION