



**WEB VERSION**

## TABLE OF CONTENTS

<b>1 Warnings and Cautions</b> .....	4
<b>2 Product Description</b> .....	5
2.1 General Description .....	5
2.2 Meter Features .....	5
2.3 Meter Certifications .....	5
2.4 Physical Description .....	5
2.4.1 Single Meter .....	5
2.4.2 Enclosures .....	6
<b>3 Technical Specifications</b> .....	6
3.1 Electrical Specifications .....	7
3.2 Input/Output Connections.....	7
<b>4 Installation Instructions</b> .....	10
4.1 Preparation .....	10
4.2 List of Materials .....	10
4.3 Mounting the Enclosure.....	10
4.3.1 Mounting Location.....	10
4.3.2 Drilling Conduit Holes.....	11
4.3.3 Mounting Procedure and Conduit Installation.....	12
4.4 Installation of Voltage Lines .....	12
4.5 Installation of Current Transformers.....	13
4.5.1 General Requirements .....	13
4.5.2 Installing Solid Core CTS .....	13
4.6 Testing the Installation .....	16
<b>5 Maintenance</b> .....	16
<b>6 Troubleshooting</b> .....	17
<b>7 Warranty</b> .....	18
<b>8 Contact Information</b> .....	19

## 1 WARNINGS AND CAUTIONS

The following section contains installation and wiring instructions for the Leviton Mini Meter™. If technical assistance is required at any point during the installation, contact information can be found at the end of this manual. Leviton is not responsible for damage to the meter caused by incorrect wiring, which will void the product's warranty.

### WARNING:

- **TO AVOID FIRE, SHOCK OR DEATH; TURN OFF POWER** at circuit breaker or fuse and test that the power is off before installing product or servicing current transformers.
- **TO AVOID FIRE, SHOCK OR DEATH;** Look inside the meter and electrical panel for possible exposed wire, broken wire, damaged components or loose connections.
- Make sure all tools used during installation have proper installation ratings.
- Installations should be done in accordance with local codes and current National Electric Code requirements, and performed by trained, qualified professionals.
- Equipment used in a manner not specified by this document impairs the protection provided by the equipment.

### CAUTIONS:

- Verify the model number and electrical specifications of the device being installed to confirm they are appropriate for the intended electrical service (see Section 3).
- Consult local codes for any possible permits or inspections required before beginning electrical work.
- Ensure the conduit for the installation is flexible and non-metallic. For outdoor applications conduit and conduit fittings must be rated UL Type 4X for outdoor enclosures. Failure to use the appropriate conduit impairs the degree of equipment protection.

## 2 PRODUCT DESCRIPTION

### 2.1 General Description

The Leviton Mini Meter is a self-powered, current transformer (CT) rated electronic kilowatthour (kWh) meter designed for permanent connection to an electrical service. Mini Meter devices come in single element (2-wire) and dual element (3-wire) configurations.

### 2.2 Meter Features

- Revenue-grade accuracy with solid-core or easy to install split core CTs
- Built in LCD display with optional external mechanical counter
- Encapsulated model for harsh environments
- Multiple load monitoring with a single meter
- AMR compatible isolated pulse outputs
- 5-year warranty

### 2.3 Meter Certifications

- UL Approved (100A & 200A models only) for use in the US or Canada
- Conforms to accuracy requirements set forth in ANSI C12.1 and C12.16
- Certified to California Division of Measurement Standards
- Approved by the California Energy Commission for use in the California Solar Initiative's Performance Based Incentive Program
- Approved by State of Maryland Public Service Commission in accordance with applicable ANSI C12.1 requirements

### 2.4 Physical Description

#### 2.4.1 Single Meter

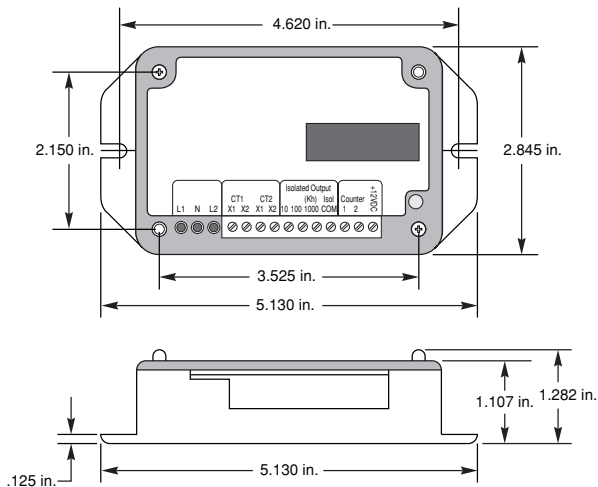

Figure 1 - Single Mini Meter Case Dimensions

## 2 PRODUCT DESCRIPTION

### 2.4 Physical Description

#### 2.4.2 Enclosures

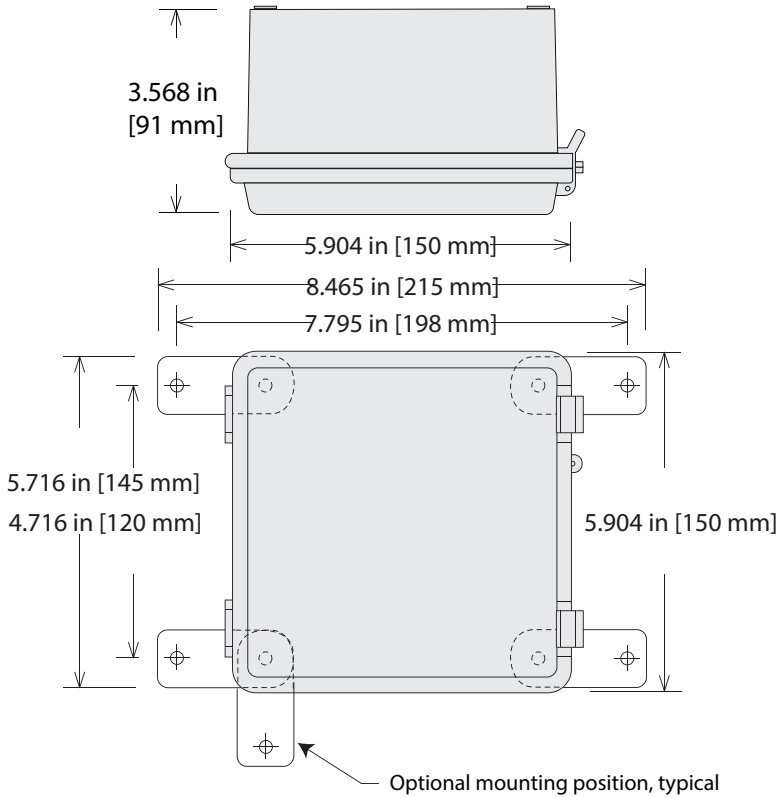

Figure 2 - Small enclosure and mounting dimensions

### 3 TECHNICAL SPECIFICATIONS

#### 3.1 Electrical and Environmental Specifications

The Mini Meter device falls under UL Circuit Category III: devices for measurements performed in the building installation. The electrical and environmental specifications for Mini Meter devices are given in the table below.

Input Configurations	1 Phase, 2 wire 1 or 2 Phase, 3 wire
Supply Voltage Range (L1 or L2 to Neutral)	Min. 102 VAC Max. 138 VAC
Maximum Input Power	8 VA
Maximum Rated Current <sup>1</sup>	220 A primary for 200 A models 110 A primary for 100 A models 0.11 A secondary for 0.1 A secondary models 0.22 A secondary for 0.2 A secondary models
Line Frequency	50-60 Hz
Power Factor Range	0.5 to 1.0, leading or lagging
Accuracy	+/- 0.5% of registration @ 1.0pf, 2 to 200 A +/- 0.75% of registration @ 0.5pf, 2 to 200 A
Operating Temperature Range	-30 to +70 degrees C
Rated Pollution Degree <sup>2</sup>	2
Rated Relative Humidity	80%
Branch Fuse Holder Klemsan ASK2 or equiv.	250 V, 1 A, fast acting, short time lag
Terminal Blocks Mini Meter Dinkle/International Connector OSTVI110152	4.4 in-lb of torque maximum

**Table 1 - Electrical and Environmental Specifications**

- <sup>1</sup> Product approved for use with included Leviton Current Transformers, as follows:
- **200A:** Part Numbers CDA02-x12 (CDA02-K12, CDA02-R12, CDA02-L12, CDA02-212, CDA02-312) for Solid Core, 0.72" Diameter CTs or CTD02-K16 for Split Core 1" CTs
  - **100A:** Part Numbers CDA01-x12 (CDA01-K12, CDA01-R12, CDA01-L12, CDA01-212, CDA01-312) for Solid Core, 0.72" Diameter CTs or CTD01-K16 for Split Core 1" CTs
- <sup>2</sup> Pollution Degree 2: normally only non-conductive pollution occurs. Occasionally, however, a temporary conductivity caused by condensation can happen.

### 3 TECHNICAL SPECIFICATIONS

#### 3.2 Input/Output Connections and User Display

Figure 3 - Mini Meter Connections and Display

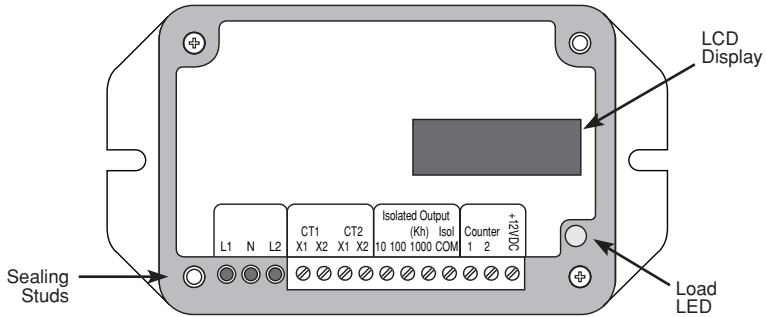

Table 2A - Input Connections

<u>Voltage Inputs (wire connections)</u>	<u>Description</u>
L1	Black wire, voltage input, Line 1, 120 V with respect to neutral
N	White wire, Neutral input
L2	Red wire, voltage input, Line 2, 120 V with respect to neutral (2 phase models only)
 <u>CT Inputs</u>	
CT1 : X1	Current Transformer input, CT1. Colored wire of CT 1
CT1 : X2	Current Transformer input, CT1. White wire of CT1
CT2 : X1	Current Transformer input, CT2. Colored wire of CT 2. (2 phase models only)
CT2 : X2	Current Transformer input, CT2. White wire of CT2 (2 phase models only)



### 3 TECHNICAL SPECIFICATIONS

#### 3.2 Input/Output Connections and User Display

Table 2B - I/O Connections

<u>Outputs</u>	<u>Description</u>
10, Isolated Output (10 Wh/P, Kh = 10)	Isolated pulse output: 5 watthours on, 5 watthours off, referenced to ISOL COM NOT TO BE USED FOR FIELD WIRING
100, Isolated Output (100 Wh/P, Kh=100)	Isolated pulse output: 50 watthours on, 50 watthours off, referenced to ISOL COM
1000, Isolated Output (1 kWh/P, Kh=1000)	Isolated pulse output: 500 watthours on, 500 watthours off, referenced to ISOL COM
ISOL COM	Isolated common for 10/100/1000 isolated outputs
Counter (kh = 100 or kh = 1000)*	For 12 VDC electro-mechanical counter
+12 VDC (MMS and MMD models only)	+12 VDC @ 10ma Max output (Not Isolated for pre-wiring only)

\* Recommended Leviton Mechanical Counters part numbers are:  
MPCTR-1KW (1kWh) and MPCTR-TKW (0.1kWh).

Table 3 - Display Indicators

<u>LED Indicators</u>	<u>Description</u>
Load LED (green)	50% duty cycle LED to verify proper meter function when connected to a load. At 200 watts, LED will flash 1.5 minutes on, 1.5 minutes off; with no load, LED will remain on or off
LCD Display	LCD display that shows total kWh (also displays kw demand, instantaneous kw, error codes if applicable, and more information upon boot. Refer to the Mini Meter manual for complete information)

## 4 INSTALLATION INSTRUCTIONS

### 4.1 Preparation

#### WARNINGS

- **TO AVOID FIRE, SHOCK OR DEATH; TURN OFF POWER** at circuit breaker or fuse and test that power is off before installing product or servicing current transformers.
- **TO AVOID FIRE, SHOCK OR DEATH;** Look inside the meter and electrical panel for possible exposed wire, broken wire, damaged components or loose connections.
- Specification for branch circuit protection, rated min. 250 V, 1A, for voltage sense / input leads.

### 4.2 List of Materials

- Mini Meter MMU and associated mounting materials.
- Line 1, Line 2, and Neutral hook-up wires as needed for the electrical service. Wires must be 18 AWG or larger and insulated for 300 VAC min (NOT INCLUDED).
- Current Transformers (CTs): This product is designed for use with Leviton CTs; see Section 3.2 for details (NOT INCLUDED IN ALL MODELS).
- Flexible, non-metallic conduit and fittings; UL Type 4X for outdoor applications (NOT INCLUDED).

### 4.3 Mounting the Enclosure

#### 4.3.1 Mounting Location

- Meter installations require a switch or circuit breaker as part of the building installation.
- The switch or circuit breaker must be marked as the disconnecting device for the MMU.
- It is recommended that the enclosure be mounted near the disconnecting device in an area with adequate ventilation.
- The enclosure should not be positioned in a manner that makes it difficult to operate the disconnecting device.
- Ensure that the CT and voltage lead lengths (and conduit lengths) are capable of reaching the enclosure from the breaker panel.
- If a suitable mounting location near the load center cannot be found, additional in-line fuses or circuit breaker may be required in accordance with NEC regulations.

## 4 INSTALLATION INSTRUCTIONS

### 4.3.2 Drilling Conduit Holes

The bottom panel and lower half of the side panels work best for conduit opening locations in outdoor single meter enclosures. Select the location that makes wire installation easiest for the given environment. If the side panels are used, holes should be centered approximately half an inch from the bottom of the enclosure. Hole sizes must be appropriate to fittings, and large enough to fit all voltage and CT wiring (4-7 18 AWG min. wires insulated for 300 V min.). Care should be exercised to keep drill bit away from components inside the enclosure. **UL Type 4X conduit and fittings must be used in order to maintain the outdoor rating of the enclosure.**

## 4 INSTALLATION INSTRUCTIONS

### 4.3.3 Mounting Procedure and Conduit Installation

1. Attach the mounting brackets to the back of the enclosure with the four provided screws as shown in Figure 4.
2. Fasten the enclosure to the selected surface via mounting holes.
3. Verify that the enclosure is not loose and that all connections are secure.
4. Attach the conduit between enclosure and load center, routing wires as necessary for later use.
5. Make sure the conduit fittings are aligned properly and tightened securely to prevent moisture from entering the enclosure (outdoor applications).

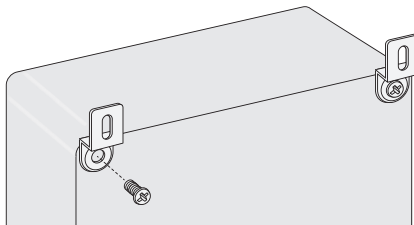

Figure 4 - Mounting the Enclosure

### 4.4 Installation of Voltage Lines

**WARNING: TO AVOID FIRE, SHOCK OR DEATH; TURN OFF POWER** at circuit breaker or fuse and test that the power is off before wiring! Verify that branch circuit fuse specifications meet local electric codes (see section 3.2).

Voltage connections must be made in accordance with NEC Section 240 and all other local electrical code requirements

1. Field wired voltage connections are made to the Mini Meter terminal block. The rated torque for these terminal blocks is 4.4 in-lb, and can be used with solid and stranded copper wires, at 12-18 AWG.
2. Verify that branch circuit fuse specifications meet local electric codes.
3. Connect 18 AWG min., 300 V min. insulated wiring for Line voltages and Neutral to the appropriate locations in the breaker panel, in accordance with all national and local electrical codes; see Figure 7 for wiring diagram.
4. Route wires through the conduit if not already done.
5. Trim the wire to the appropriate length to avoid coils of excess wiring.
6. Strip wiring to approximately .300 inches if needed and connect to the appropriate terminals. Wires should be tightened so that they are held snugly in place, but do not to over-tighten, as this may compress and weaken the conductor.

## 4 INSTALLATION INSTRUCTIONS

### 4.5 Installation of Current Transformers

**WARNING: TO AVOID FIRE, SHOCK OR DEATH; TURN OFF POWER** at circuit breaker or fuse and test that the power is off before installing or servicing current transformers.

**CAUTION:** In accordance with NEC, CTs may not be installed in any panel board where they exceed 75% of the wiring space of any cross-sectional area. Violation of the electric code could be punished by a fine or imprisonment.

#### 4.5.1 General Requirements

- Leviton-provided CT leads are approximately 48 inches. Wire insulation should be stripped so that the bare conductor length that connects to the meter terminal block does not exceed 0.300 inches.
- CTs should be securely fastened such that they will not slide down to live terminals.
- Wires should be tightened so that they are held snugly in place, but do not to overtighten, as this may compress and weaken the conductor.
- Current and voltage inputs must be installed 'in phase' for accurate readings (e.g. CT1 on Line 1, CT2 on Line 2)
- Field wired CT connections are made to the Mini Meter terminal block. The rated torque for these terminal blocks is 4.4 in-lb, and can be used with solid and stranded copper wires, at 12-18 AWG.
- Splices on the CT leads must be within the meter enclosure, not inside the conduit.



Figure 5 - Leviton Solid Core CTs

#### 4.5.2 Installing solid core CTs

**WARNING: TO AVOID FIRE, SHOCK OR DEATH; TURN OFF POWER** at circuit breaker or fuse and test that the power is off before installing or servicing current transformers.

1. Route CT wires through the conduit if not already done.
2. Trim the wire to the appropriate length to avoid coils of excess wiring.
3. Strip wiring to approximately .300 inches and connect to the appropriate terminals as described above.
4. With power turned off, disconnect each monitored conductor and slide on a CT, ensuring the CT is correctly oriented as noted above.
5. Reconnect the conductors.

**NOTE:** Failure to install CTs in the correct orientation and on the correct phase will lead to inaccurate meter readings.

## 4 INSTALLATION INSTRUCTIONS

### 4.5 Variations and Installation of Current Transformers

- Leviton split core CTs (Figure 6): The side with the white dot, H1, must face the incoming LINE. White wire connects to X2 terminal, black wire connects to X1 terminal.



Figure 6 - Leviton Split Core CTs

## 4 INSTALLATION INSTRUCTIONS

### SINGLE ELEMENT, MINI METER WIRING DIAGRAM

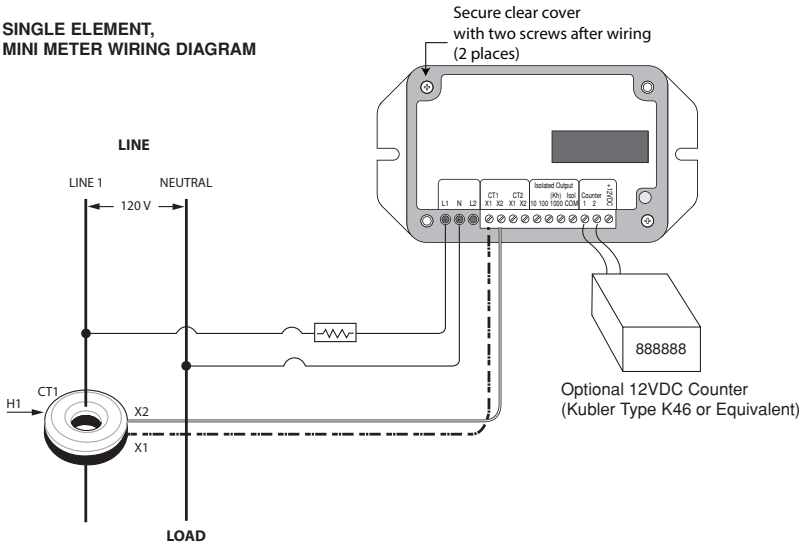

### DUAL ELEMENT, MINI METER WIRING DIAGRAM

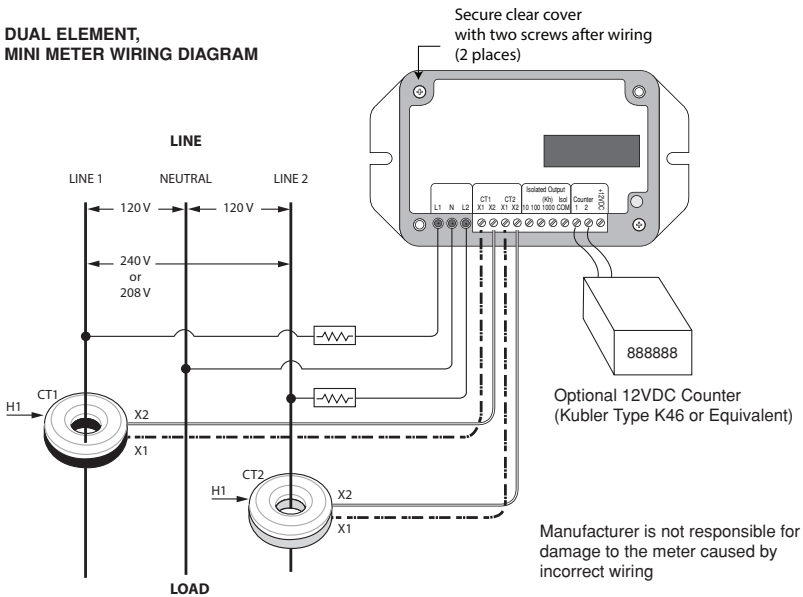

Figure 7 - Dual and single element Mini Meter hookup diagram

## 4 INSTALLATION INSTRUCTIONS

### 4.6 Testing the Installation

#### Testing Voltage

The LCD illuminates when the Mini Meter has a proper power supply. Voltage should also be tested using an AC voltmeter to verify that the voltage across voltage line terminals (L1 to Neutral and L2 to Neutral) is not in excess of the maximum rated voltage.

#### Load LED

The load LED is described in section 3. This LED should be cycling at 50% duty cycle when the meter is connected properly and a sufficient load is applied.

## 5 MAINTENANCE

Properly installed meters with sound connections and secure conduit fittings should not require user maintenance. If the meter is functioning abnormally, consult the Troubleshooting guide. If the answer cannot be found there, contact Technical Support.



## 6 TROUBLESHOOTING

### Problem

1. LCD not illuminated
2. Load LED not flashing
3. Registered consumption low

### Solution

- Check to make sure all connections are wired properly
- Test the voltage being supplied to the meter using an AC voltmeter
- With power off, remove any additional line fuses and test with ohmmeter
- Verify CT connections and orientations
- Make sure there is sufficient load to draw a significant current
- Test the voltage being supplied to the meter using an AC voltmeter
- Check to make sure the reverse phase arrow is not shown on the LCD
- Make sure that current and voltage connections are in phase.
- Check power connections and fuses

## 7 WARRANTY

### LIMITED 5 YEAR WARRANTY AND EXCLUSIONS

Leviton warrants to the original consumer purchaser and not for the benefit of anyone else that this product at the time of its sale by Leviton is free of defects in materials and workmanship under normal and proper use for five years from the purchase date. Leviton's only obligation is to correct such defects by repair or replacement, at its option. **For details visit [www.leviton.com](http://www.leviton.com) or call 1-800-824-3005.** This warranty excludes and there is disclaimed liability for labor for removal of this product or reinstallation. This warranty is void if this product is installed improperly or in an improper environment, overloaded, misused, opened, abused, or altered in any manner, or is not used under normal operating conditions or not in accordance with any labels or instructions. **There are no other or implied warranties of any kind, including merchantability and fitness for a particular purpose,** but if any implied warranty is required by the applicable jurisdiction, the duration of any such implied warranty, including merchantability and fitness for a particular purpose, is limited to five years. **Leviton is not liable for incidental, indirect, special, or consequential damages, including without limitation, damage to, or loss of use of, any equipment, lost sales or profits or delay or failure to perform this warranty obligation.** The remedies provided herein are the exclusive remedies under this warranty, whether based on contract, tort or otherwise.

For Technical Assistance Call: 1-800-824-3005 - [www.leviton.com](http://www.leviton.com)

### FOR CANADA ONLY

For warranty information and/or product returns, residents of Canada should contact Leviton in writing at **Leviton Manufacturing of Canada Ltd to the attention of the Quality Assurance Department, 165 Hymus Blvd, Pointe-Claire (Quebec), Canada H9R 1E9** or by telephone at **1 800 405-5320.**

© 2018 Leviton Mfg. Co., Inc.

## 8 CONTACT INFORMATION

Leviton Manufacturing Co., Inc.  
201 N. Service Rd. Melville, NY 11747

Technical Assistance: 1-800-824-3005



**WEB VERSION**