

Models 6P201-C02, 6W201-C02, 6W201-D02, 6W201-E02
0.5% Mini Meter in Flush Mount Enclosure with Wireless AMR Option

Product Description
Technical Specifications
Installation Instructions



List of Figures	2
List of Tables.....	2
1. Product Description	3
1.1 General Description	3
1.2 Meter Features.....	3
1.3 Meter Certifications	3
1.4 Model Numbers.....	3
1.4 Physical Description.....	4
1.4.1 Mini Meter in Flush Mount Enclosure.....	4
1.4.2 Tamper Protection.....	4
1.5 Functional Description	4
2. Technical Specifications	5
2.1 Electrical Specifications.....	5
2.2 Input/Output Connections and User Display.....	6
Table 3: I/O connections	7
Table 4: Display indicators.....	7
3. Installation Instructions	8
3.1. Explanation of Warning Symbols.....	8
3.2 Safety Precautions	8
3.3 Preparation	9
3.4 List of Materials.....	9
3.5 Setting up the Enclosure	9
3.5.1 Selecting a Mounting Location	9
3.5.2 Making Conduit Openings.....	10
3.6 Installation of Voltage Lines.....	10
3.7 Installation of Current Transformers.....	10
3.8 Flush Mount Enclosure Installation.....	12
3.9 Testing the Installation.....	14
4. Wireless Automatic Meter Reading	14
5.1 Network Activation.....	15
5. Maintenance	18
6. Troubleshooting/FAQ.....	18
7. Returned Policy/Warranty Information	20

List of Figures

Figure 1: Mini Meter flush mount enclosure dimensions	4
Figure 2: Mini Meter connections and display	6
Figure 3: Leviton solid core CTs	11
Figure 4: Enclosure installation	12
Figure 5: Mini Meter hookup diagram	14
Figure 6: Wireless Network consisting of MDTs, Repeater, DCAP	15
Figure 7: Tehama Wireless MDT	17

List of Tables

Table 1: 0.5% Mini Meter Kit Models & Options.....	3
Table 2: Electrical and environmental specifications.....	5
Table 3: I/O connections	7
Table 4: Display indicators.....	7

1. Product Description

1.1 General Description

The Leviton 0.5% Mini Meter is a self-powered, current transformer (CT) rated electronic kilowatt-hour (kWh) meter designed for permanent connection to an electrical service. This guide is for use with the 0.5% dual element (1PH 120/240V or 2PH 120/208V, 3-Wire) Mini Meter in a flush mount enclosure.

1.2 Meter Features

- Exceeds Revenue-grade accuracy – 0.5%
- Built in LCD
- Multiple load monitoring with a single meter
- Isolated Pulse outputs
- Tamper Micro Switch
- Optional wireless AMR enabled
- Reverse-phase LED indicator
- 5-year warranty

1.3 Meter Certifications

- UL Listed for use in the US or Canada
- NRTL certified compliance with ANSI C12.1 and C12.20 (0.5).
- Wireless option complies with NY DPS and NYSERDA requirements for revenue grade submeters

1.4 Model Numbers

6P201-C02	Flush Mount Mini Meter Kit, LCD Display, Isolated Pulse Outputs
6W201-C02	Flush Mount Mini Meter Kit, LCD Display, Isolated Pulse Outputs, TOU enabled kWh Meter Data Transceiver
6W201-D02	Flush Mount Mini Meter Kit, LCD Display, Isolated Pulse Outputs, TOU and Temperature enabled kWh Meter Data Transceiver
6W201-E02	Flush Mount Mini Meter Kit, LCD Display, Isolated Pulse Outputs, TOU and 1% Delta Temperature enabled kWh Meter Data Transceiver

Table 1: 0.5% Mini Meter Kit Models & Options

1.4 Physical Description

1.4.1 Mini Meter in Flush Mount Enclosure

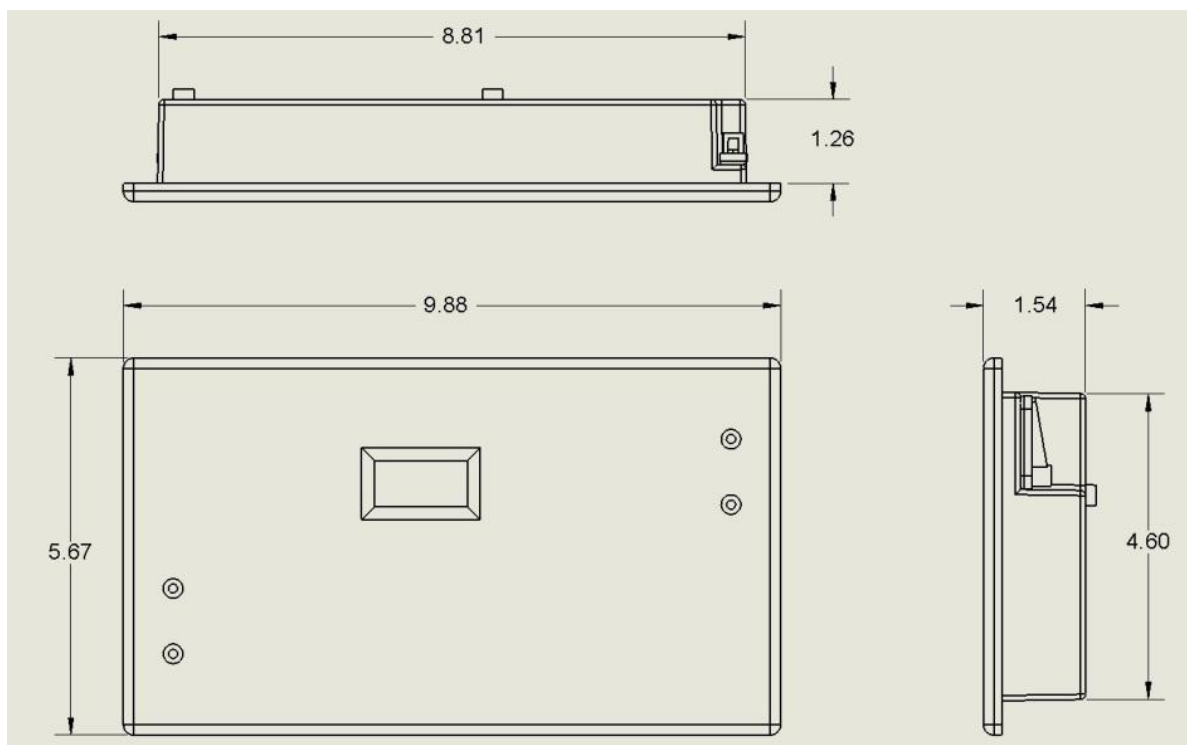

Figure 1: Mini Meter flush mount enclosure dimensions

1.4.2 Tamper Protection

Two flat-head screws that secure the enclosure front may be covered with adhesive-type security seals that indicate tampering when removed. Also, some models provide a tamper indication through the wireless AMR system when enclosure cover is removed.

1.5 Functional Description

The 6W201 versions of the Mini Meter accurately quantifies electrical energy usage of 1PH 3W (2-pole) 120/208V or 120/240V loads. Solid Core Current Transformers are used to measure current flowing to a load. Energy information (pulses) is recorded by the onboard wireless transceiver, which time stamps kWh readings in 15-minute intervals and sends it over a secure wireless network to a Data Concentrating Access Point (DCAP), where data from a network of meters is stored for on a local computer for billing or energy management functions, or data can be pushed from the DCAP or pulled from remote locations via an Ethernet connection.

2. Technical Specifications

2.1 Electrical Specifications

Mini Meters fall under UL Circuit Category III: a device for measurements performed in the building installation. The electrical specifications for Mini Meters are given in the table below.

Input Configurations	1 or 2 Phase, 3 wire
Supply Voltage Range (L1 or L2 to Neutral)	Min. 102 VAC Max. 138 VAC
Maximum Input Power, L1 and L2	8 VA
Maximum Rated Current ¹	220 A primary 0.11 A secondary
Line Frequency	60 Hz
Power Factor Range	0.5 to 1.0, leading or lagging
Accuracy	+/- 0.5% of registration @ 1.0pf, 2 to 200 A +/- 0.75% of registration @ 0.5pf, 2 to 200 A
Operating Temperature Range	-20 to +50 degrees C
Rated Pollution Degree ²	2
Rated Relative Humidity	80%
Terminal Blocks: Dinkle/International Connector EK508-11P or equiv.	4.4 in-lb of torque maximum

Table 2: Electrical and environmental specifications

¹Product approved for use with included Leviton Current Transformers, as follows:
200A: Part number CDA01-K12 (black) or CDA01-R12 (red).

²Pollution Degree 2: Normally only non-conductive pollution occurs. Occasionally, however, a temporary conductivity caused by condensation must be expected.

2.2 Input/Output Connections and User Display

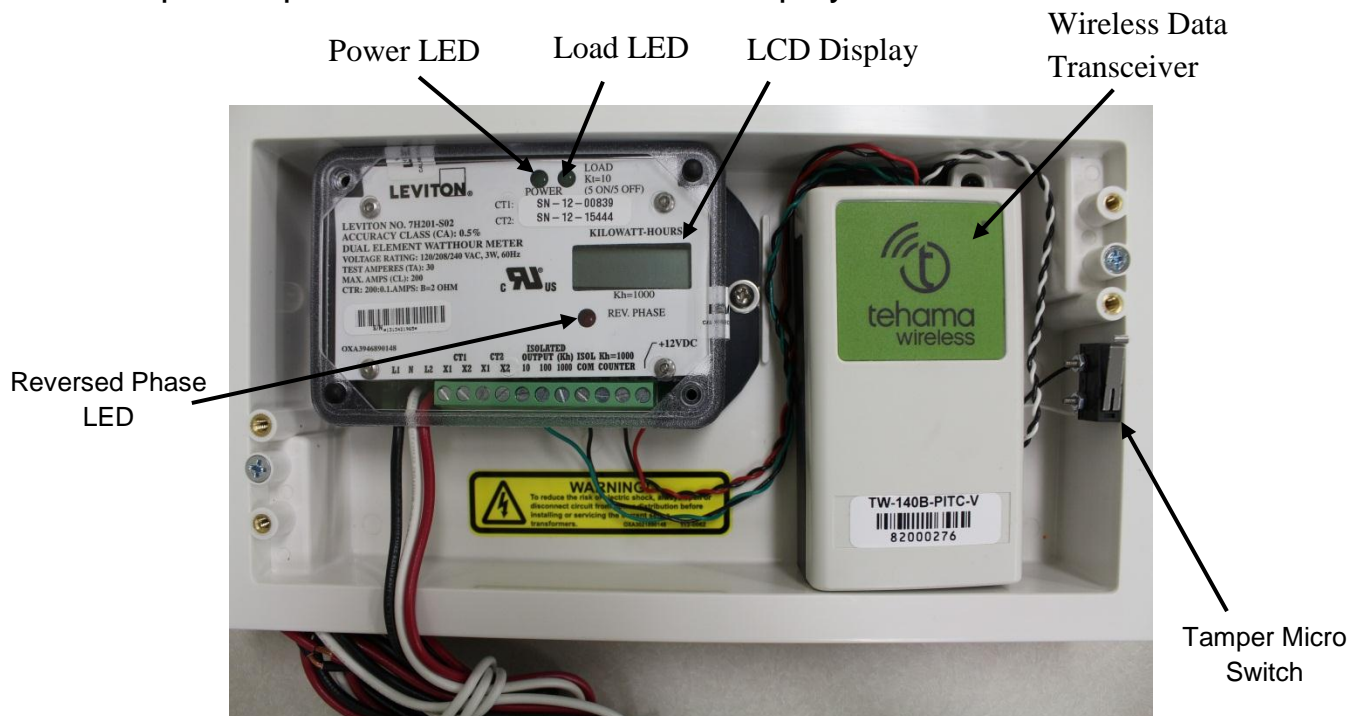

Figure 2: Mini Meter connections and display

<u>Voltage Inputs (wire connections)</u>	<u>Description</u>
L1	Black wire, voltage input, Line 1, 120V with respect to neutral
N	White wire, Neutral input
L2	Red wire, voltage input, Line 2, 120V with respect to neutral
<u>CT Inputs</u>	
CT1 : X1	Current Transformer input, CT1. Colored wire of CT1
CT1 : X2	Current Transformer input, CT1. White wire of CT1
CT2 : X1	Current Transformer input, CT2. Colored wire of CT2
CT2 : X2	Current Transformer input, CT2. White wire of CT2
<u>Outputs</u>	
10, Isolated Output (10 Wh/P, Kh = 10)	Isolated pulse output: 5 wathours on, 5 wathours off, referenced to ISOL COM. Connected at factory to wireless transceiver.

MINI METER FLUSH MOUNT INSTALLATION GUIDE

	NOT TO BE USED FOR FIELD WIRING
100, Isolated Output (100 Wh/P, Kh=100)	Isolated pulse output: 50 watthours on, 50 watthours off, referenced to ISOL COM
1000, Isolated Output (1 kWh/P, Kh=1000)	Isolated pulse output: 500 watthours on, 500 watthours off, referenced to ISOL COM (not available on models with T suffix)
ISOL COM	Isolated common for 10/100/1000 isolated outputs
Counter (kh = 100 or kh = 1000)*	For 12 VDC electro-mechanical counter
Counter (kh = 100 or kh = 1000)*	For 12 VDC electro-mechanical counter
+12 VDC	12 V DC output @ 3 mA max.

Table 3: I/O connections

*Recommend Leviton counter MPCTR-1KW (1 kWh models), MPCTR-TKW (0.1 kWh models) or equivalent

<u>LED Indicators</u>	<u>Description</u>
Power LED (green)	Illuminates when the meter is supplied with proper voltage
Load LED (green)	50% duty cycle (at constant load) LED to verify proper meter function when connected to a load. At 200 watts, LED will illuminate for 1.5 minutes, then turn off for 1.5 minutes; with no load, LED will remain on or off
Reverse Phase LED (red)	Illuminates when a problem with meter phasing exists. With no load, LED may be on or off. See section 3.7 for CT installation instructions
LCD Display	LCD displays shows total kWh

Table 4: Display indicators

3. Installation Instructions

The following section contains installation and wiring instructions for the Leviton Mini Meter in indoor flush mount enclosure. If technical assistance is required at any point during the installation, contact information can be found at the end of this manual. Leviton is not responsible for damage to the meter caused by incorrect wiring.

3.1. Explanation of Warning Symbols



Indicates the need to consult the operation manual due to the presence of a potential hazard.



Indicates the presence of electric shock hazards. Prior to proceeding, de-energize the circuit and consult the operation manual.



Indicates that the equipment is protected throughout by double insulation.

3.2 Safety Precautions

WARNING

- **Warning: To avoid fire, shock or death, turn off all power supplying the equipment before performing any wiring operations. Use a properly rated voltage sensing device to confirm power is off.**
- **Installation of electric meters requires working with possibly hazardous voltages. These instructions are meant to be a supplement to aid trained, qualified professionals.**
- **Bonding is not automatic for metal conduit connections; separate bonding is to be provided.**
- **Installations should be done in accordance with local codes and current National Electric Code requirements.**
- **Equipment used in a manner not specified by this document impairs the protection provided by the equipment.**

Failure to follow these warnings could result in serious injury or death.

3.3 Preparation

1. Verify the model number and electrical specifications of the device being installed to confirm they are appropriate for the intended electrical service (see Section 2).
2. Consult local codes for any possible permits or inspections required before beginning electrical work.
3. Make sure all tools to be used during installation have proper insulation ratings.
4. Check the Mini Meter and electrical panel for possible exposed wire, broken wire, damaged components or loose connections.

3.4 List of Materials

- Mini Meter, flush mount enclosure and associated mounting materials, two #6 x 1 $\frac{5}{8}$ drywall screws.
- Additional wiring for CT or voltage leads extension if needed. Wires must be 18 AWG or thicker and insulated for 300 VAC min.
- Current Transformers (CTs): This product is designed for use with Leviton CTs; see Section 2.2 for details.
- Conduit and fittings.

3.5 Setting up the Enclosure

3.5.1 Selecting a Mounting Location

- Mini Meter flush mount enclosures require a switch or circuit breaker as part of the building installation.
- The switch or circuit breaker must be marked as the disconnecting device for the Mini Meter.
- It is recommended that the enclosure be mounted near the disconnecting device.
- Ensure that the CT and voltage lead lengths (and conduit lengths) are capable of reaching the enclosure from the load center.
- If a suitable mounting location near the load center cannot be found, additional in line fuses or circuit breaker may be required in accordance with NEC regulations.

3.5.2 Making Conduit Openings

It is recommended that conduit holes be placed in the lower left compartment of the flush mount enclosure, just below the Mini Meter I/O terminal block. Conduit hole sizes must be appropriate to fittings, and large enough to fit all voltage and CT wiring (4-7 18 AWG min. wires insulated for 300 V min.).

3.6 Installation of Voltage Lines



Confirm that service is disconnected before any connections are made.

1. Based on desired mounting location, check if additional in-line fuses are required to meet local electric codes. (See section 3.8 for mounting location requirements and recommendations).
2. Mini Meters come standard with voltage wires pre-connected to the metering board.
3. Route wires through conduit to the breaker panel.
4. Trim wires to the appropriate length to avoid coils of excess wiring and strip to approximately 0.300 inches.
5. Following all national and local electric codes, connect wires to appropriate locations in the load center. Wires should be tightened so that they are held snugly in place, but do not to over-tighten, as this may compress and weaken the conductor. See figure 5 for Mini Meter wiring diagram.

3.7 Installation of Current Transformers



Warning: To avoid fire, shock or death, always open or disconnect the circuit from the power distribution system of a building before installing or servicing current transformers.



In accordance with NEC, CTs may not be installed in any panel board where they exceed 75% of the wiring space of any cross-sectional area.

General Requirements:

- Field wired CT connections are made to the Mini Meter terminal block. The rated torque for these terminal blocks is 4.4 in-lb, and can be used with solid and stranded copper wires, at 12-18 AWG.
- Splices on the CT leads must be within the meter enclosure, not inside the conduit.

Leviton-provided CT leads are approximately 48 inches. Wire insulation should be stripped so that the bare conductor length that connects to the meter terminal block does not exceed 0.300 inches.

- CTs should be securely fastened such that they will not slide down to live terminals.
- Wires should be tightened so that they are held snugly in place, but do not to over-tighten, as this may compress and weaken the conductor.
- Current and voltage inputs must be installed 'in phase' for accurate readings (e.g. CT1 on Line 1, CT2 on Line 2); see Figure 5.
- Leviton solid core CTs (Figure 3): In accordance with CT label, the LINE side of CT must face incoming Line. White lead connects to X2 of CT connection (CT1:X2 or CT2:X2). Colored lead connects to X1 of the corresponding CT connection (CT1:X1 or CT2:X1).



Figure 3: Leviton solid core CTs

Installing solid core CTs

1. Route CT wires through the conduit if not already done.
2. Trim the wire to the appropriate length to avoid coils of excess wiring.
3. Strip wiring to approximately .300 inches and connect to the appropriate terminals as described above.
4. With power turned off, disconnect each monitored conductor and slide on a CT, ensuring the CT is correctly oriented as noted above.
5. Reconnect the conductors.

Failure to install CTs in the correct orientation and on the correct phase will lead to inaccurate meter readings. The Mini Meter wiring diagram is shown in Figure 5.

3.8 Flush Mount Enclosure Installation

The Flush Mount Enclosure uses preinstalled clamps (Figure 4). After performing steps 1 and 2, follow the instructions for the appropriate enclosure.

1. Select a desired installation location following the guidelines of 3.5.1.
2. Make a 4.5" x 8.75" hole in the mounting surface for the enclosure to be situated. See Figure 1 for enclosure dimensions.
3. Unscrew the clamps to their maximum distance and orient them parallel with the enclosure as show in frame 2 of Figure 4.
4. Slide the meter into the wall opening and tighten the clamp screws as in frame 3 of Figure **Error! Reference source not found.**
5. After running the tests in Section 3.9, place the cover on the meter and attach with the provided screws.

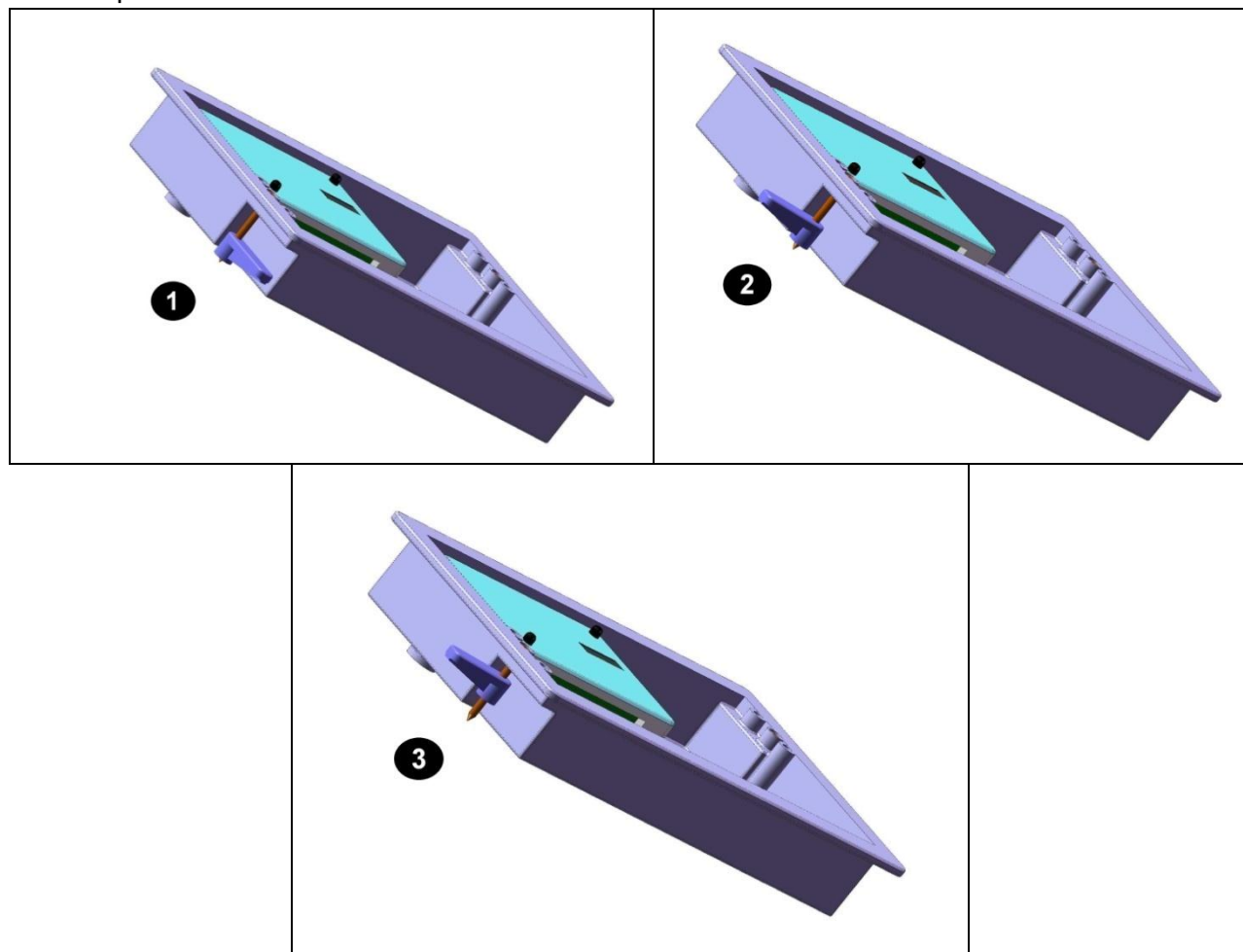
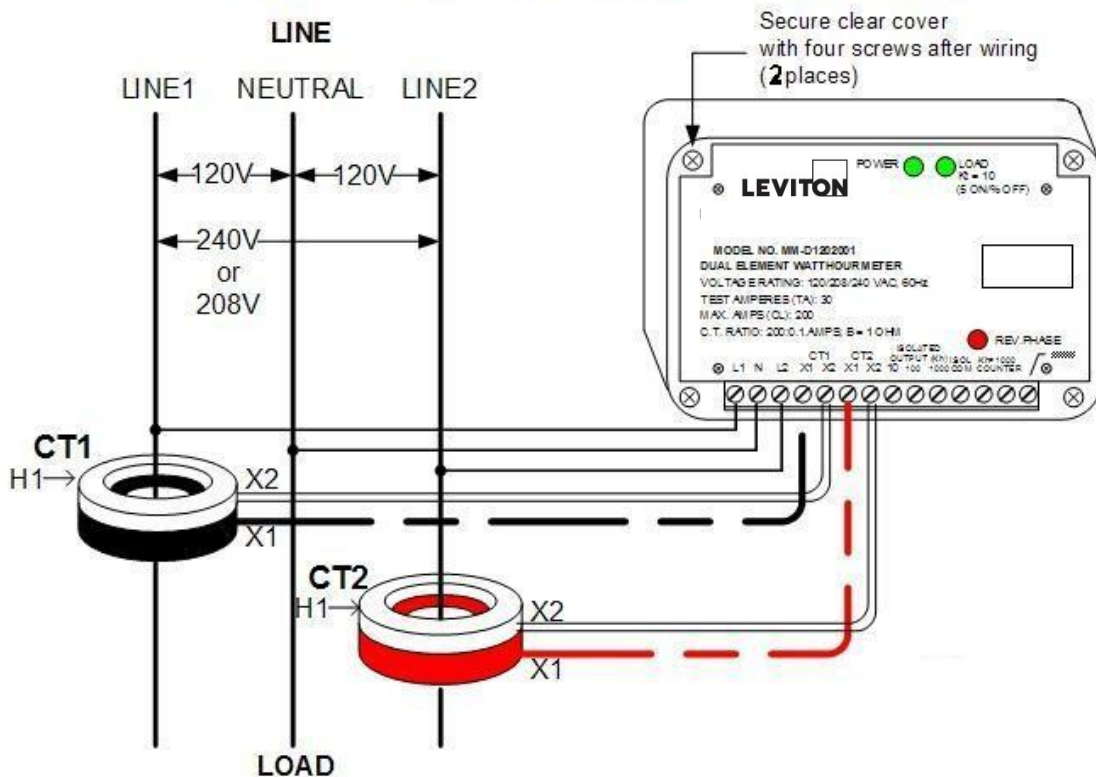
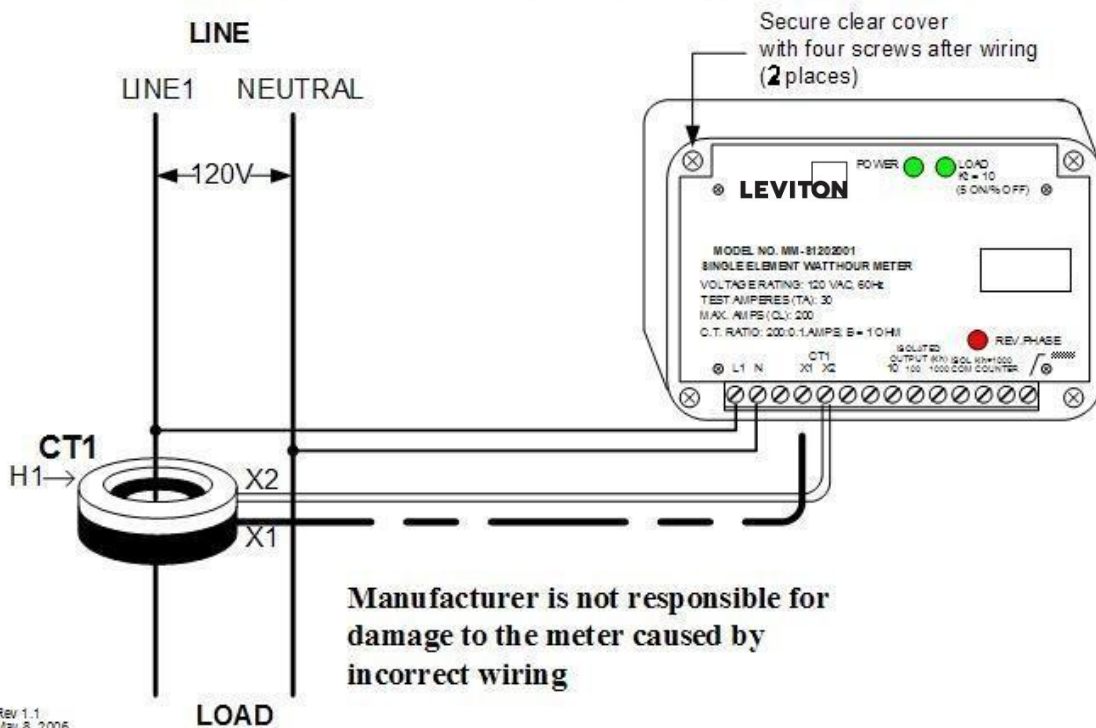

Figure 4: Enclosure installation

DUAL ELEMENT MINI METER HOOKUP DIAGRAM



SINGLE ELEMENT MINI METER HOOKUP DIAGRAM



Rev 1.1
May 8, 2006

Figure 5: Mini Meter hookup diagram

3.9 Testing the Installation

Testing Voltage

The power LED illuminates when the Mini Meter has a proper power supply. Voltage should also be tested using an AC Voltmeter to verify that the voltage across voltage line terminals (L1 to Neutral and L2 to Neutral) is not in excess of the maximum rated voltage in section 2.2.

CT Reverse Phase Indicator

Mini Meters have a red reverse phase indicator LED as described in section 2.3. **A load current of at least 1 Amp must be present through one of the CT primary circuits in order for the reverse phase LED to function correctly.** If a proper load is connected, and the LED is illuminated, power down the voltage supply and verify that CTs are installed correctly.

Load LED

The load LED is described in Table 4. This LED should be cycling at 50% duty cycle when the meter is connected properly and a constant load is applied.

4. Wireless Automatic Meter Reading

Built into 6W201 models are a wireless Meter Data Transceiver (MDT) as shown in Figure 2. Six wires connect between transceiver and the Mini Meter. The transceiver logs and time stamps accumulated pulses in 15 minute intervals and sends the data via a mesh network of transceivers and repeaters (if required) to a Data Concentrating Access Point (DCAP). Repeaters and DCAPs are sold separately.

4.1 MDT Power and Pulse input are pre-wired to isolated pulse output terminals:

4.1.1 Power: Red wire to meter terminal +12 VDC and black to terminal CNT.

4.1.2 Meter Pulse Input: Green wire to terminal 10 and black to ISOL COM.

4.1.3 Tamper Switch: White and black to tamper proof micro-switch.

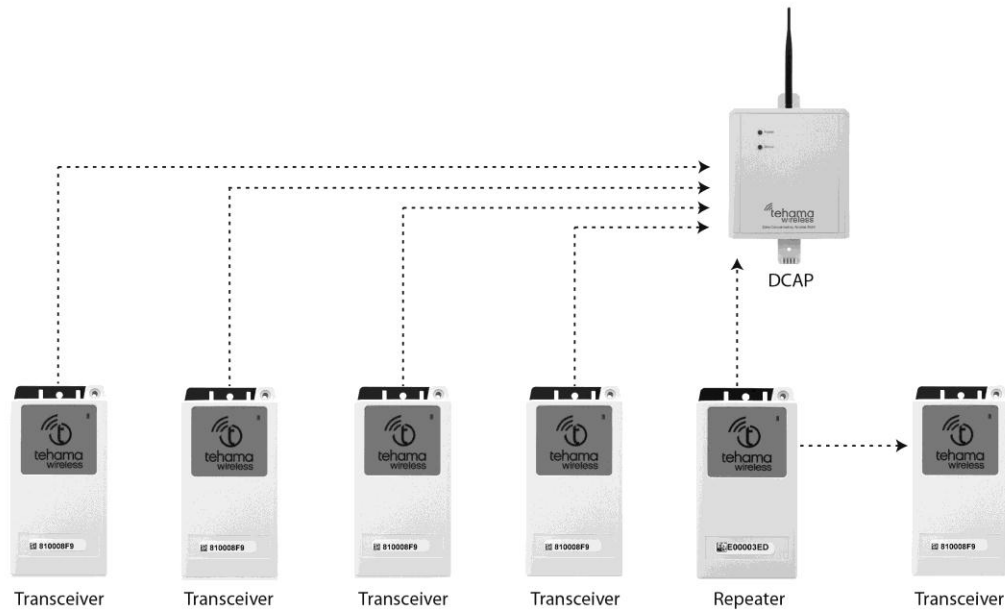

Figure 6: Wireless Network consisting of MDTs, Repeater, DCAP

5.1 Network Activation

For complete wireless system commissioning information, consult the Tehama QuickStart Guide-1212A.docx, which can be downloaded from www.tehamawireless.com.

DCAP

A Tehama Network starts with the DCAP. Without a DCAP there are no originating Beacons and therefore no Network to join. Thus it needs to be the first device that is installed and powered.

With the DCAP in place and plugged in, the Repeater Backbone can then be installed.

Repeaters

Repeaters should be powered up starting with those closest to the DCAP and working your way out to the remote edges of the property. This will allow remote Repeaters to see the Network Backbone when they are turned on. Powering up in this order is not necessarily critical, but if not followed then the power-up LED indications on a remote Repeater may not provide the useful feedback to the installer that it has successfully joined the Network.

Once the Repeaters are in place, you can use the Commissioning and Installation Tool (CIT) software (supplied on disc with purchase of the DCAP) to observe the performance of the network backbone.

MDTs

Once the Network is in place, you can begin to place the MDTs in their locations and turn them on. Alternatively the MDTs can be installed with the meters in the off state. As soon as the meter begins to generate pulses, the first pulse will automatically turn on the MDT and begin to transmit.

MDTs can also be placed and turned on before the Network Backbone is up and operating, but there are a few disadvantages:

- MDTs could take up to four hours to check in after the Network Backbone is put in place.
- You don't get the LED feedback that gives you instant feedback that the MDT is communicating successfully with the Network.

Placement:

- Like repeaters, MDTs should not be mounted inside a metal box or near a metal wall (i.e. heating furnace or electrical panel).
- MDTs must be mounted using velcro, tie-wraps, or screws. Don't let the MDT dangle by the pulse input wire.
- Avoid locations with dampness, high humidity, or an abundance of mold.

MDT & Repeater power-up

MDT and Repeater devices come from the factory in a powered off state. They need to be powered up during the commissioning process so they can register with the DCAP. MDT's must be wired to the meter described in Section 4.1 in order to commission the device.

The yellow circle shows where a hidden button is on the enclosure. It may take a few times to get the feel of it, but an LED in the clear window to the right gives you feedback when the button is pushed.



Figure 7: Tehama Wireless MDT

- To turn a device ON, press and hold the button until the LED flashes off (about four seconds) then release the button.
- After about 30 seconds the LED flash frequency should change from slow to fast. After another 30 seconds or so, the LED will stay solid for 10 seconds then go out. The long flash indicates the device is communicating with the network.
- To turn a device OFF, press and hold the button until the LED flashes off (about four seconds) then release the button. The unit will give a double flash indicating the off state.

LED Flash Indication States during power-up

Slow flash: The device is listening for Beacons from a DCAP and/or Repeaters.

Rapid Flash: The device has heard a DCAP and/or Repeater and is in process of joining the Network.

Solid Flash: The device has confirmation that it has successfully joined the Network.

LED Flash indication States when button is momentarily pressed

Single Flash: The device is in a light sleep mode. It will wake up every so often to listen for Beacons.

Double Flash: The device is OFF

10 second on: The device is successfully communicating with a Network.

Note that a light sleep mode is entered when a device is turned on but cannot hear a radio network beacon. If no network is present, a device will stay in the slow flash state for 90 seconds then go to sleep for some time before trying to listen again for a beacon. It is highly recommended a device be turned off if no Network is nearby.

5. Maintenance

Properly installed meters with sound connections and secure conduit fittings should not require user maintenance. If the meter is functioning abnormally, consult the FAQ/Troubleshooting guide in Section 7. If the answer cannot be found there, contact Leviton technical support (see Section 7).

6. Troubleshooting/FAQ

<u>Problem</u>	<u>Solution</u>
1. Power LED not illuminated	<ul style="list-style-type: none"> • Check to make sure all connections are wired according to section 3.6 • Test the voltage being supplied to the meter using an AC voltmeter • With power off, remove any additional line fuses and test with ohmmeter
2. Load LED not flashing	<ul style="list-style-type: none"> • Verify CT connections and orientations (see Section 3.7) • Make sure there is sufficient load to draw a significant current • Test the voltage being supplied to the meter using an AC voltmeter
3. Registered consumption low	<ul style="list-style-type: none"> • Check to make sure the reverse phase LED is not on • Even if the reverse phase light is off, double-check CT orientations. One CT installed in the incorrect direction doesn't always illuminate the reverse phase LED • Make sure that current and voltage connections are in phase (see Sections 3.6 and 3.7) • Check power connections and fuses
4. Reverse phase LED illuminated	<ul style="list-style-type: none"> • Verify orientation and connection of CT wires (see Section 3.7) • Ensure that phasing is correct (CT1 on Line 1, CT2 on Line 2) • Verify that a load drawing more than 1 Amp is connected to the meter

FAQ

Q: What is AMR equipment?

A: AMR is Automatic Meter Reading equipment. This typically consists of radio transmitters, repeaters and a collector that monitors, records, and is capable of transmitting data to a third party billing service (RBC).

Q: Why are the current transformers color coded (Black & white, red & white, and blue & white)?

A: CT1 needs to monitor the same phase used to power the meter on line 1, CT2 needs to monitor the same phase used to power line 2. Color coding helps the installer maintain correct phasing.

Q: Can the meters be tampered with after installation?

A: The flush mount enclosures provide two drilled fillister head screws through which wire seals can be installed. Also, tamper-evident labels can be affixed to the cover after installation.

Q: Can voltage input wires and current transformer secondary leads be routed through the same conduit?

A: Yes, provided Leviton supplied CTs are used.

Q: I accidentally installed my CTs backwards; can I switch the X1 and X2 terminal connections instead of flipping the CT?

A: Yes, but this practice is not recommended as service technicians may believe that meter is wired incorrectly.

Q: I still can't get my meter to work, what now?

A: Contact technical support via phone or on our website given in the following section.

7. Returned Material Policy and Warranty Information

After acceptance, all sales of meters are final. Leviton, in its sole discretion, authorizes product returns in appropriate circumstances, subject to such conditions as Leviton may specify. Any such return is subject to the express prior authorization and approval of Leviton. Buyer must notify Leviton at 800-736-6682 (telephone) or 503-404-5594 (fax) and request a Returned Material Authorization Number (RMA Number) and state the specific reason for return. Unauthorized returns will not be accepted.

When requesting an RMA Number please supply the following information:

1. Distributors name and address
2. Model number of meter
3. Original purchase order number
4. Reason for return

All paperwork and boxes must be marked with an RMA number issued by Leviton. All authorized returned materials must be shipped freight prepaid to Leviton to the address specified below. Leviton is not responsible for uninsured packages or packages lost by your carrier.

Leviton 20497 SW Teton Avenue Tualatin, Oregon 97062

All returns are subject to a handling/restocking charge, except for product shipped in error or products under warranty. All charges (modification, repair, restock etc) related to returned products will be determined by Leviton upon evaluation. All shipping costs are the responsibility of the buyer.

METERS RETURNED FOR CREDIT*

Replacement meter ordered

- *RMA Number requested by stocking distributor for credit must be accompanied by a purchase order for material of equal or greater value.* 0% Restock Charge

NO replacement meter ordered 25% Restock Charge

METERS RETURNED FOR REPAIR (STILL UNDER WARRANTY)*

No defects found \$75.00 evaluation charge

Defects not covered under warranty Charges upon evaluation

Defects found covered under warranty No Charge

METERS RETURNED FOR EVALUATION (NO LONGER UNDER WARRANTY)*

Evaluation charge of \$75.00 applies

Other charges will apply depending on evaluation by Leviton

**Prices as of May 01, 2009 and subject to change*

Leviton Manufacturing Co., Inc. Global Headquarters

201 N. Service Rd. Melville, NY 11747-3138 • Tech Line: 1-800-824-3005 • FAX: 1-800-832-9538

Leviton Manufacturing Co., Inc. Lighting & Energy Solutions

20497 SW Teton Avenue, Tualatin, OR 97062 • Telephone: 1-800-736-6682 • FAX: 503-404-5594

Metering Tech Support: (6:00AM-4:00PM P.S.T. Monday-Friday):

meters@leviton.com 1-800-959-6004

Leviton Manufacturing of Canada, Ltd.

165 Hymus Boulevard, Pointe Claire, Quebec H9R 1E9 • Telephone: 1-800-469-7890 • FAX: 1-800-563-1853

Leviton S. de R.L. de C.V.

Lago Tana 43, Mexico DF, Mexico CP 11290 • Tel. (+52) 55-5082-1040 •

www.leviton.com.mx

Visit our Website at www.leviton.com/les

© 2012 Leviton Manufacturing Co., Inc. All rights reserved. Subject to change without notice.