

INSTALLATION INSTRUCTIONS

WARNINGS AND CAUTIONS:

- **TO AVOID FIRE, SHOCK, OR DEATH; TURN OFF POWER AT CIRCUIT BREAKER OR FUSE AND TEST THAT THE POWER IS OFF BEFORE WIRING!**
- **DO NOT** control a load in excess of the specified ratings. Damage to the unit, fire, electric shock, personal injury or death can occur. Check your load ratings to determine suitability for your application.
- To be installed and/or used in accordance with electrical codes and regulations.
- If you are not sure about any part of these instructions, consult an electrician.

WARNINGS AND CAUTIONS:

- Do not install this unit to control a receptacle.
- Do not touch the surface of the lens. Clean outer surface with a damp cloth only.
- The Cat. No. ODS10-IFx occupancy sensor is intended to replace a standard light switch.
- Use this device **ONLY WITH COPPER OR COPPER CLAD WIRE.**

TOOLS NEEDED TO INSTALL YOUR SENSOR

Slotted/Phillips Screwdriver Electrical Tape Pliers
 Cutters Small Slotted Screwdriver

FEATURES

- Leviton's Sahara style design
- Switches electronic ballasts
- Low Profile, tamper-resistant lens
- Ambient Light Override

DESCRIPTION

Leviton Cat. No. ODS10-IFx, Designer Wall Switch Occupancy Sensor, is designed to detect motion from a heat-emitting source (such as a person entering a room) within its field-of-view (monitored space) and automatically switch lights ON and OFF. The controlled lights will remain ON until no motion is detected and the scheduled time-delay has expired.

The Occupancy Sensor senses motion within its coverage area of 2100 sq. ft. (195.1 m²) maximum and controls the connected lighting. This is a self-contained device which provides sensing and light control. The Occupancy Sensor will turn the lights ON when motion is initially detected, and keep the lights ON for as long as motion is detected.

The Occupancy Sensor uses a small semiconductor heat detector that resides behind a multi-zone optical lens. This Fresnel lens establishes dozens of zones of detection. The sensor is sensitive to the heat emitted by the human body. In order to trigger the sensor, the source of heat must move from one zone of detection to another. The device is most effective in sensing motion across its field-of-view, and less effective sensing motion towards or away from its field-of-view (refer to **Field-of-View diagrams**). Keep this in mind when selecting the installation location.

Note that occupancy sensors respond to rapid changes in temperature, so care should be taken not to mount the device near a climate control source (i.e. radiators, air exchanges, and air conditioners). Hot or cold drafts will look like body motion to the device and will trigger it if the unit is mounted too close. **It is recommended to mount the Occupancy Sensor at least 1.8 m away from then climate control source.** The device can be mounted in a single gang wallbox.

In addition, it is also recommended NOT to mount the Occupancy Sensor directly under a large light source. Large wattage bulbs (greater than 100W incandescent) give off a lot of heat and switching the bulb causes a temperature change that can be detected by the device. Mount the Occupancy Sensor at least 6 ft. away from large bulbs. If it necessary to mount the device closer, lower the wattage of the bulb directly overhead

INSTALLING YOUR SENSOR

NOTE: Use check boxes when Steps are completed.

Step 1 **WARNING: TO AVOID FIRE, SHOCK, OR DEATH; TURN OFF POWER** at circuit breaker or fuse and test that power is off before wiring!

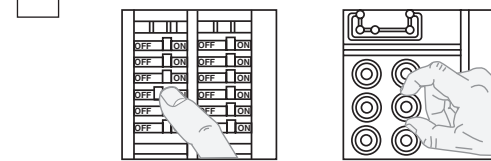

Step 2 **Identifying your wiring:**

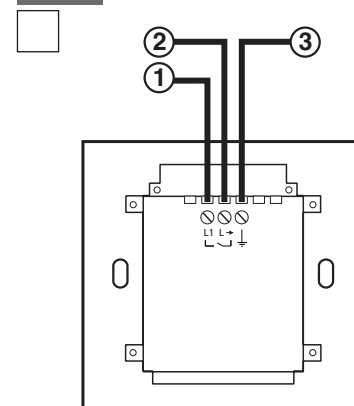

ODS10-IFx
 1. Line(hot) - (L1)
 2. Load - L →
 3. Earth

Step 3 **Preparing and connecting wires:**

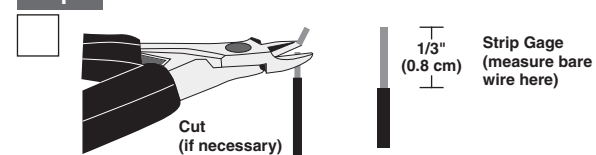

- Make sure that the ends of the wires from the wall box are **straight (cut if necessary)**.
- Remove insulation from each wire in the wall box as shown.
- Insert wire in proper terminal as shown below and tighten to 4kg-cm. Terminals will accept 3-.2mm² wire.

Step 4 **Installing your Sensor – Single-Pole Application:**

NOTE: The Cat. No. ODS10-IFx requires an Earthing wire bonded to the Neutral at the source to operate properly. If the Earthing wire is floating this device will not work.

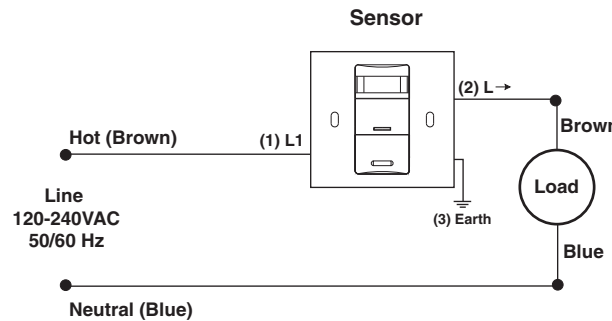

WIRING SENSOR:

Connect wires per **WIRING DIAGRAM** as follows: Insert wires into proper terminals and use a flat head screwdriver to turn terminal screws clockwise to secure wires.

- Green with yellow stripe in wall box to Earth terminal.
- Line Hot wall box wire to Line terminal.
- Load wall box wire to Load terminal.

NOTE: Allow 1 minute for warm-up after connecting and energizing.

Step 5 **Testing your Sensor prior to completely mounting in wall box:**

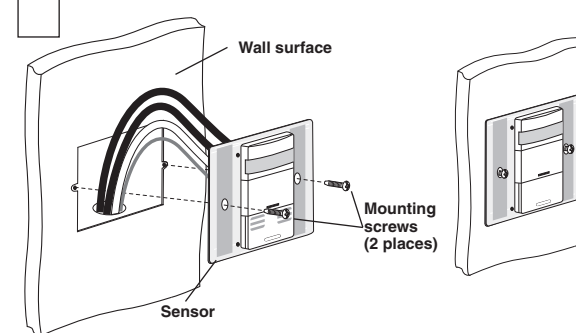

NOTE: Dress wires with a bend to relieve stress when mounting device.

- Position all wires to provide room in outlet wall box for device.
- Partially secure device using long mounting screws provided.
- Restore power at circuit breaker or fuse.

NOTE: To avoid **PERMANENT DAMAGE** to the unit, be careful NOT TO **OVERTURN** the control knobs or levers when setting the Sensor. The controls can be accessed by removing the wallplate (if applicable) and control panel cover (refer to **Control Panel Diagram**). Use a small straight blade screwdriver to adjust knobs and a finger to adjust the blinder levers.

NOTE: **DO NOT** press in on blinder levers or use excessive force (refer to **Control Panel Diagram**).

• Attach the Control Panel cover when the desired settings are complete.

If lights do not turn ON, refer to the **TROUBLESHOOTING** section.

Step 6 **Device Mounting:**
TURN OFF POWER AT CIRCUIT BREAKER OR FUSE.

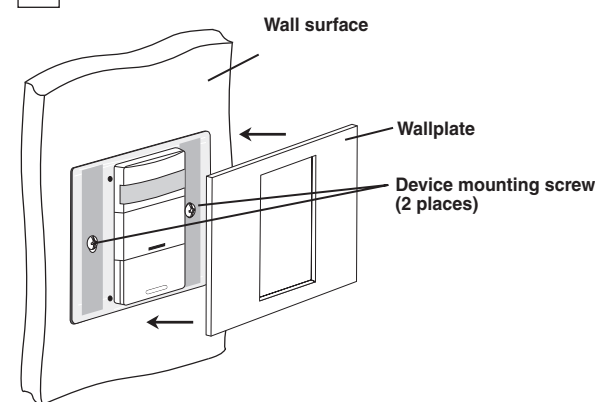

- Secure device by firmly tightening mounting screws.
- Install Sahara style wallplate (sold separately).

Step 7 **Restore Power:**

Restore power at circuit breaker or fuse. **Installation is complete.** Leave the room and the lights will turn OFF after the selected time-out expires.

FEATURES

BLINDERS: The blinders can narrow the field-of-view of the device to prevent unwanted activation from traffic in adjacent space. There are two blinders, and each operate independently. To operate the blinders, use a finger or small screwdriver to move the blinder adjustment levers toward or away from the center of the device.

The blinder levers are found above the control knobs and below the text 'BLINDERS' on the control panel. With both levers moved fully towards the center, the field-of-view is narrowed to 60°. With both levers moved fully away from the center, the field-of-view is at a maximum 180° (refer to **Control Panel Diagram**).

TIME-DELAY: Cat. No. ODS10-IFx will turn lights ON when motion is detected. When motion is no longer detected, the Sensor Unit will wait a certain amount of time and then turn the lights OFF. This wait time is called 'time-out'.

The "time-out" is selected from four (4) preset values. Pointing the arrow at one of the markings on the face chooses the value of time. The following selections are available:

| Face Marking | Value of Time |
|----------------|---|
| (/) Slash Mark | 30 second fixed time-out used for performing a walk-test. |
| 1 | 10 minute time-out |
| 2 | 20 minute time-out |
| 3 | 30 minute time-out |

The "time-out" is factory preset to ten (10) minutes. Refer to figure 2A. NOTE: All time durations mentioned in the instructions are approximate within 10 seconds.

AMBIENT LIGHT: The Ambient Light Level is the amount of light present in a room without any artificial light added. If there is already enough light in a room, the occupant may not need further artificial light. Cat. No. ODS10-IFx has an adjustment to keep the lights from turning ON if there is enough light already present. **The adjustment should be made when the ambient light is at the level where artificial light is needed.** Follow these steps to make a more accurate adjustment of the Light Control.

SETTINGS

1. With the lights ON, rotate the Time Control fully counter-clockwise (CCW) to set the time-out to the thirty (30) second test mode (refer to Control Panel Diagram).
2. Rotate the Light Control fully CCW.
3. Cover the Sensor Unit with an opaque material, or leave the room and let the Sensor Unit time-out and turn the lights OFF.
4. Rotate the Light Control clockwise (CW) slowly, until the light turns ON. This is the setting for the current level of light in the room.
5. Adjustments are finished.

Manual ON Mode: When the light control is in the fully CCW position the lights will never automatically turn ON. In this mode the lights need to be manually turned ON by the push-button, and will turn OFF with the absence of motion.

If the light control is in the fully CW position, the lights will turn ON whenever motion is detected, even in full daylight. Intermediate settings will cause the lights to turn ON only when the ambient light is below the level selected by the light control.

NOTE: The ambient light in a room will change with the time of day and the season of the year.

RANGE: To decrease detection range and sensitivity, rotate the knob CCW (refer to Control Panel Diagram). The detection range can be adjusted from 100% down to 36%.

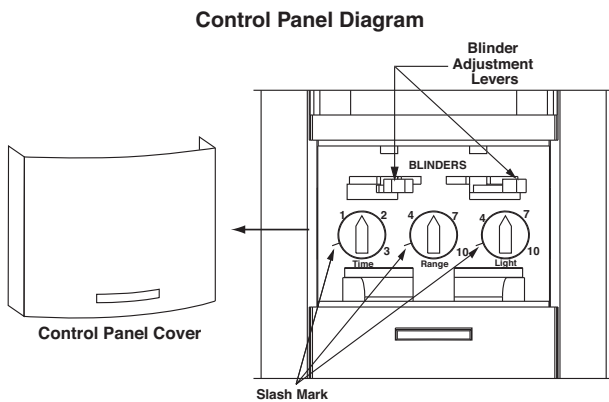

OPERATION

PUSH BUTTON:

Cat. No. ODS10-IFx has a push-button switch that will toggle the lights. If the lights are OFF, the lights will turn ON when the button is pressed, and remain ON in the presence of motion. In the absence of motion, the Sensor Unit will time-out and turn the lights OFF.

If the lights are ON, the lights will turn OFF when the button is pressed. The lights will stay OFF regardless of motion detected, until the time-out expires. After the time-out expires, the lights will turn ON with the next detected motion. This is useful for slide or film presentations.

NOTES:

- The Motion Indicator LED will blink every 2 seconds while motion is detected.
- In Manual-On mode, the button must be pressed to turn the lights ON. In the absence of motion, the unit will time-out and turn the lights OFF.
- If Manual-On mode is desired, keep the Light knob in the fully counter-clockwise (CCW) position.

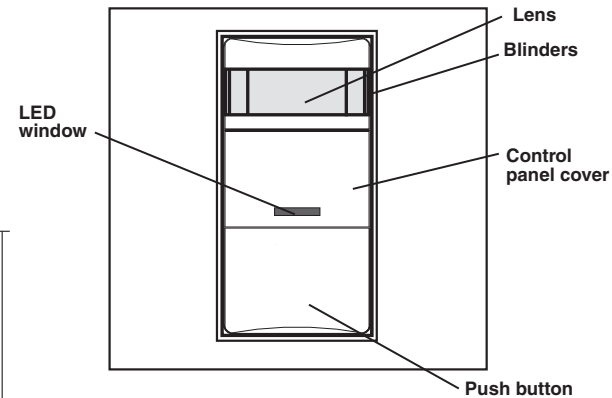

Field - of - View (Horizontal)

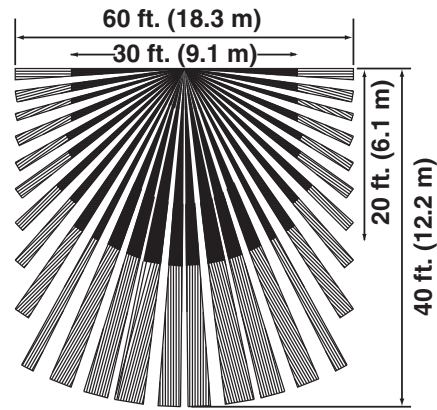

Side (Vertical) Field - of - View

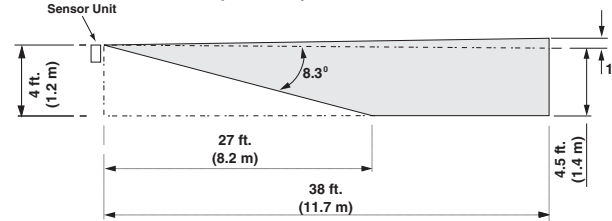

TROUBLESHOOTING

1. If there is no response from the unit (the light never turns ON and the LED never blinks) 1 1/2 minutes after power is applied, then uninstall device and verify there is an Earth connection at the wallbox. If there is an Earth connection, verify wiring.
2. If the lights never turn ON, but the LED blinks, check if the Ambient Light Control Knob is pointed fully counter-clockwise (CCW). Rotate it clockwise (CW) until the lights turn ON.
3. If the lights constantly stay ON, even when the room is unoccupied:
 - A. Check the Time setting. See how this time compares to how long the lights stay ON.
 - B. Try lowering the Range Control. Rotate the knob CCW about 30°.
 - C. If the problem persists, try reducing again. Note: Do Not reduce so much that Cat. No. ODS10-IFx cannot see normal occupancy.
 - D. Be sure to use the Blinders to block any unwanted hallway traffic.
 - E. Check for reflected heat/motion as Sensor Unit may be seeing motion through a window.
 - F. Check for adjacent HVAC and/or heater ducts.
4. For additional information call Leviton's Technical Support Line.

PRODUCT INFORMATION

- For technical assistance contact us at 1-800-824-3005
- Visit our website at www.leviton.com

LIMITED 5 YEAR WARRANTY AND EXCLUSIONS

Leviton warrants to the original consumer purchaser and not for the benefit of anyone else that this product at the time of its sale by Leviton is free of defects in materials and workmanship under normal and proper use for five years from the purchase date. Leviton's only obligation is to correct such defects by repair or replacement, at its option, if within such five year period the product is returned prepaid, with proof of purchase date, and a description of the problem to Leviton Manufacturing Co., Inc., Att: Quality Assurance Department, 201 North Service Road, Melville, New York 11747. This warranty excludes and there is disclaimed liability for labor for removal of this product or reinstallation. This warranty is void if this product is installed improperly or in an improper environment, overloaded, misused, opened, abused, or altered in any manner, or is not used under normal operating conditions or not in accordance with any labels or instructions. There are no other or implied warranties of any kind, including merchantability and fitness for a particular purpose, but if any implied warranty is required by the applicable jurisdiction, the duration of any such implied warranty, including merchantability and fitness for a particular purpose, is limited to five years. Leviton is not liable for incidental, indirect, special, or consequential damages, including without limitation, damage to, or loss of use of, any equipment, lost sales or profits or delay or failure to perform this warranty obligation. The remedies provided herein are the exclusive remedies under this warranty, whether based on contract, tort or otherwise.