

LEO™

LEVITON®

LEO™ LED Zoom Ellipsoidal

Cat. No. LED00

User's Guide

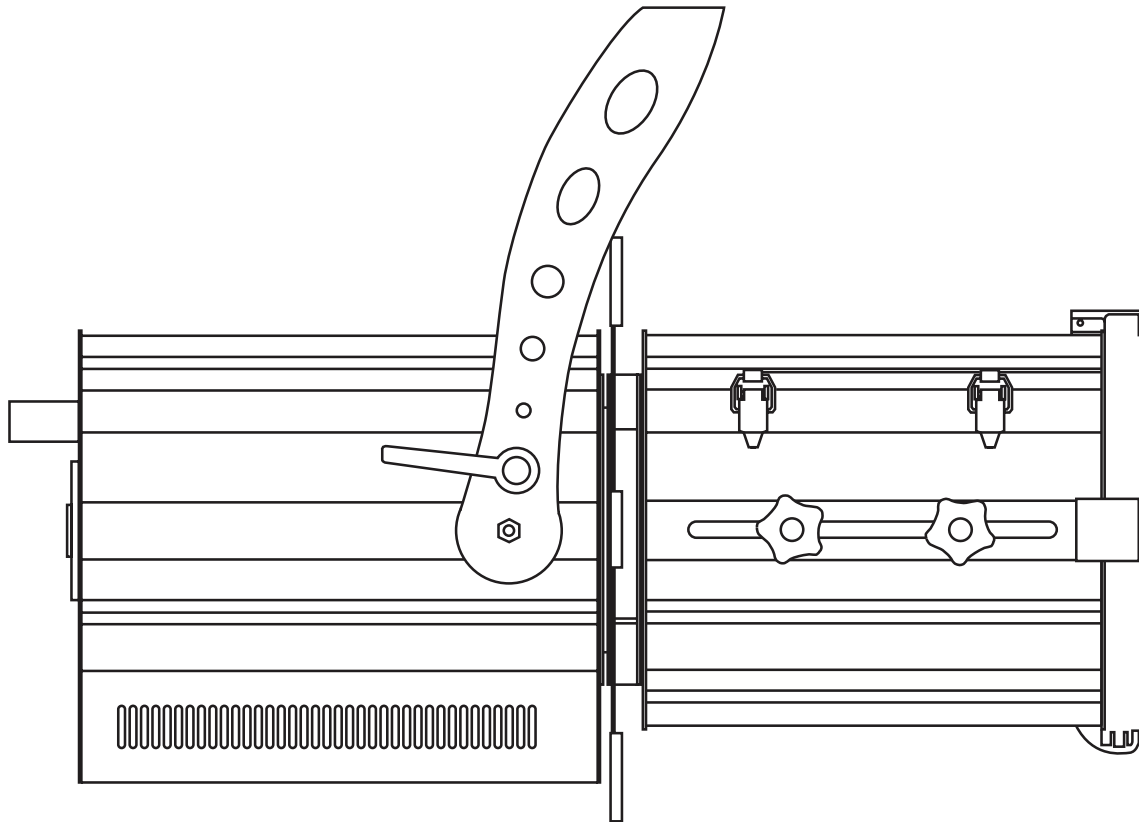

WARNINGS AND CAUTIONS

- **TO AVOID FIRE SHOCK OR DEATH; TURN OFF POWER** at circuit breaker or fuse and test that power is off before installation.
- **TO AVOID SERIOUS PERSONAL INJURY**, always connect this product to a grounded circuit.
- To be installed and/or used in accordance with electrical codes and regulations.
- If you are unsure about any part of these instructions, consult an electrician.

SAFETY NOTES

WARNING: TO AVOID DEATH, SERIOUS PERSONAL INJURY OR PROPERTY DAMAGE:

- Do not open the housing or attempt any repairs. In the unlikely event the unit may require service please contact Leviton Technical Support. Opening the housing or attempting to repair product will void the warranty.
- Do not expose this product to rain or moisture. This product is for indoor use only! (IP20) When transferring product from extreme temperature environments, (e.g., cold truck to warm humid ballroom) condensation may form on the internal electronics of the product. To avoid causing a failure, allow product to fully acclimate to the surrounding environment before connecting it to power.
- Do not operate this product if you see damage on the housing, lenses, or cables.

CATALOG LOGIC

LED00-30B; LED00-50B

Fixture	Part	Color Temperature	Housing
LED: LED Ellipsoidal	00: Light Engine 08: 8-22°Zoom 18: 18-36°Zoom 30: 30-55°Zoom	-30: 3200K -50: 5600K -LT: Lens Tube	B: Black Housing

SPECIFICATIONS

CAT. NO.	LED00
WATTAGE	200W
STANDBY LOAD	
WEIGHT	18.3 lbs. (8.3 kg)
SIZE	W 9.8" (250mm) x H 18.5" (470mm) x D 13.8" (350 mm)
ELECTRICAL	100-240 VAC, 50/60Hz
AGENCY	ETL, cETL, CE, FCC

GETTING STARTED

Thank you for choosing LEO™ LED Zoom Ellipsoidal by Leviton®. Every LEO™ LED Zoom Ellipsoidal has been thoroughly tested and has been shipped in perfect operating condition. Your package should include:

- Light Engine
- Fuse, glass tube, 6A (for 110V)
- Fuse, glass tube, 3A (for 220V)
- Safety Cable, 31.5" (800mm) with Spring Clips
- 36" - 39.5" (1m) power lead with powerCON® & PBG (NEMA 5-15P Connector)
- powerCON® B connector
- User's Guide

Power cords with alternate connectors, and, powerCON® extension cables are available. Please contact *Leviton* and review product data sheets for details.

Important: Unpack the product and check the box to make sure all the parts are in the package and are in good condition. If any of them are damaged, please contact the shipper to make a claim. If any components are missing, please contact our Customer Service Department at 1-800-736-6682.

PRODUCT INTRODUCTION

LEO™ LED Zoom Ellipsoidal is a high-performance Ellipsoidal-style LED lighting fixture that delivers bright and long throw in a choice of color temperatures (3200K and 5600K) with high color rendering index (CRI 90+). It also features beam shaping shutters, gobo/iris slots, and lens tubes that are interchangeable. The fixture is fully dimmable from 0% to 100% and can be controlled manually or via DMX controller. It also supports power linking with built-in powerCON® connectors. Virtually quiet operation makes it ideal for use in any situation. The fixture is RDM-ready for precise monitoring of the LED chip's performance and status to make maintenance easy.

IDENTIFY THE PARTS

Note: Light Engine and Lens Tubes (sold separately)



Light Engine



Lens Tube 30-55



Lens Tube 18-36



Lens Tube 08-22

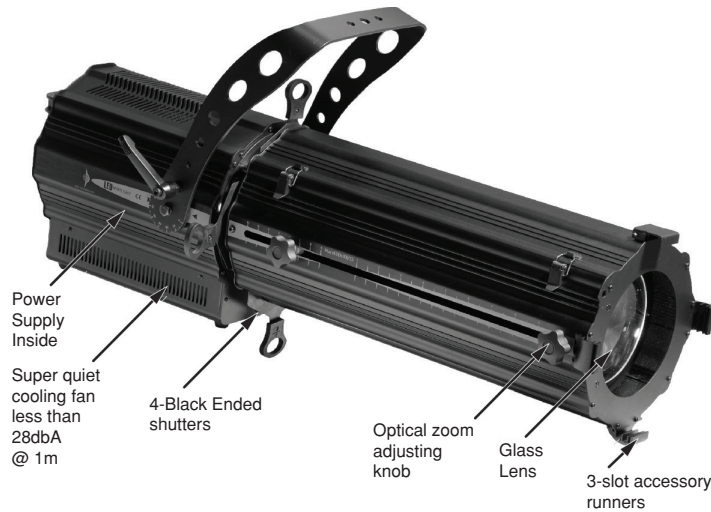

Front View



Rear View

SAFETY NOTES

- This product contains no user-serviceable parts. Do not open the housing or attempt any repairs, doing so will void the manufactures warranty. In the unlikely event the unit may require service please contact *Leviton* Technical Support.
- Do not operate this product if you see damage on the housing, lenses, or cables.
- This product is for indoor use only! (IP20) To prevent risk of fire or shock, do not expose this product to rain or moisture. When transferring product from extreme temperature environments, (e.g. cold truck to warm humid ballroom) condensation may form on the internal electronics of the product. To avoid causing a failure, allow product to fully acclimate to the surrounding environment before connecting it to power.

INSTALL LENS TUBE

CAUTION:



Do not operate the fixture without a lens tube installed.

A complete fixture requires a light engine and lens tube.

Open the lens tube cover and remove metal packing frame before use.

Rotate the tube to make sure it is attached and locked to the fixture; otherwise the tube assembly may inadvertently separate from the light engine.

To attach the lens tube, align the lens with the light engine's lens mount index and turn the lens tube as shown by the arrow until it clicks in place.

To detach the lens tube, turn the lens as shown by the arrow while pulling the two spring clips on each side of the tube. Turn the lens until it stops, and then detach it.

Align the lens with the light engine's lens mount index. Turn the lens tube as shown by the arrow until it clicks in place.

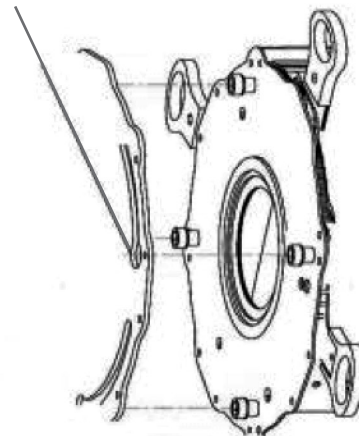
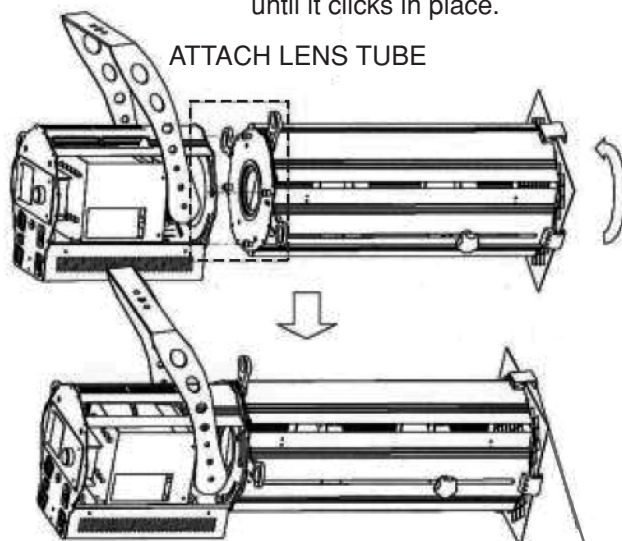

Make sure the lens tube is attached and locked to the fixture while the retaining clip is facing on top.

REPLACE FUSE

CAUTION:



Fuse pre-installed in BLACK fuse cover supports 220V AC Power only
Fuse pre-installed in GREY fuse cover supports 110V AC Power only

Always make sure you are connecting this product to the proper voltage in accordance with the specifications in this manual or on the product's specification label.

Choose the correct fuse for your voltage before connecting power.

Step 1: Unplug the product from power.

Step 2: Use a slotted screwdriver, push slightly and rotate counterclockwise to open the fuse cap.

Step 3: Take out the fuse cap and fuse. Put a new fuse inside the fuse cap.

Step 4: Screw the fuse cap back in place and reconnect power.



CONNECT POWER

CAUTION:



WARNING: TO AVOID SERIOUS PERSONAL INJURY, always connect this product to a grounded circuit.

LEO™ LED Zoom Ellipsoidal comes with a power lead terminated with a powerCON® A connector on one side, and a PBG NEMA 5-15P connector on the other side. Other connector options are available from *Leviton* or may be installed by your contractor. In addition, the fixture is designed for "Feed-Thru" operation using single power source connection at the first fixture, then, using powerCON® extensions between fixtures. The maximum load supported is 16A through the powerCON® connectors which is reduced to 15A if you use a 15A source power connector like a NEMA 5-15P.

If creating your own powerCON® connectors, use the table below to wire the included powerCON® B connector, or a local plug to the power lead.

Connection	Wire
AC Live	Brown
AC Neutral	Blue
AC Ground	Green / Yellow

CONNECT DMX

LEO™ LED Zoom Ellipsoidal uses 5-pin XLR connectors for signal transmission and can be controlled via DMX-512 protocol. The diagram below shows the fixture's XLR-5 signal ports.

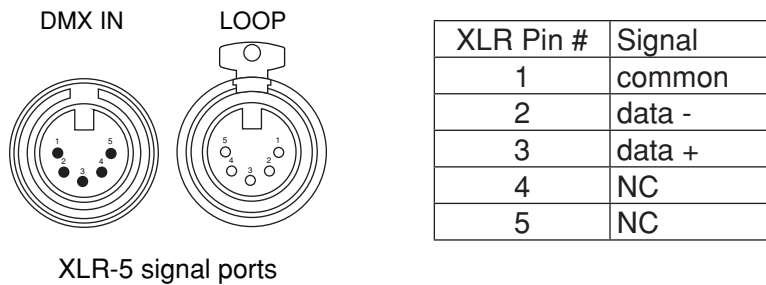

Step 1: Connect the (male) 5-pin connector side of the DMX cable to the output (female) 5-pin connector of the DMX console.

Step 2: Connect the end of the cable coming from the console which will have a (female) 5-pin connector to the fixture's input port ("DMX IN") consisting of a (male) 5-pin connector.

Step 3: Then, proceed to connect from the output port ("LOOP") as stated above to the input of the following fixture and so on.

MOUNT FIXTURE

CAUTION:



Always mount this product in a safe position with adequate ventilation and away from a heat source, at least 20" (50 cm) from adjacent surface, and no flammable materials close by while it is operating, at least 8" (20 cm) from adjacent surfaces.

Always connect the provided Safety Cable to the fixture and a suitable anchor. The safety cable should loop through the fixture yoke and be connected to a secure attachment at the other end.

LEO™ LED Zoom Ellipsoidal may be mounted in any position (max. tilting +45° to -90° from horizontal); however, make sure there is adequate room for ventilation, configuration, and maintenance.

The fixture comes with a hanging/mounting yoke to which you can attach mounting clamps. The bracket has a 0.5" (12mm) hole, which is appropriate for this purpose. Make sure the clamps are capable of supporting the weight of this product.

FIXTURE ANGLE ADJUSTMENT

The fixture can be tilted up and down to position the light where it is needed.

Step 1: Loosen the yoke fastening knob, use the handle on the rear of the unit to keep the fixture steady.

Step 2: With the fixture turned on, use the handle to tilt it to the desired angle.

Step 3: Tighten the yoke fastening knob.

BEAM SHAPING

The LEO ellipsoidal spotlight has several features which allow you to shape the beam to your needs. These features are best learned by experience and practice.

The beam can be shaped using the built-in shutters, a gobo pattern, a drop-in iris, or by rotating the lens tube.

The fixture also features a variable beam, altered by adjusting the front and rear zoom lenses in relation to each other. The front lens defines the beam spread, the rear lens the focus degree of 'softness' or 'hardness' of the beam edge or shutters.

CAUTION:



Always close the shutters when transporting or storing the product.

ACCESSORIES

LEO™ LED Zoom Ellipsoidal can accommodate many different accessories.

Description	Part Number
Lens tube 08-22	LED08-LTB
Lens tube 18-36	LED18-LTB
Lens tube 30-55	LED30-LTB
Metal Color Frame 9.65" x 9.65" (245 x 245mm)	LEDAC-CFB
Safety Guard 9.65" x 9.65" (245 x 245mm)	LEDAC-SGB
"B" Size Pattern Holder (W 3-3/4", Open Dia 2-3/4")	LEDAC-PTN
Safety Cable (included)	TA0SC-000

ACCESSORY SLOTS

CAUTION:



Accessories such as barn doors and color scrollers must be secured by a safety cable to the mounting structure.

Make sure all color / diffusion media are locked in position with the barndoor clip before hanging the fixture.

LEO™ LED Zoom Ellipsoidal has the drop-in slot for gobo holder and 3 accessory slots in the front of the fixture, and is equipped with a spring-loaded barndoor clip that prevents color frames and accessories from falling out.

Step 1: Release the barndoor clip by pushing it sideways while gently pulling backwards.

Step 2: Insert the media/accessories, secure with a safety cable where necessary.

Step 3: Lock the barndoor clip by pushing sideways while gently pushing forward.

OPERATION

CAUTION:



Do not touch this product's housing during operation because it may be very hot if overheated.

The maximum ambient temperature is 95°F (35°C). Do not operate this product at a higher temperature.

Do not cover the ventilation holes when operating to avoid internal overheating.

Avoid direct eye exposure to the light source while the product is on.

In case of a serious operating problem, stop using this product immediately!

LEO™ LED Zoom Ellipsoidal will start a self-checking process when power is applied. The unit will display the DMX address for dimming when ready to use. For standard operation, connect the fixture to a power source (100~240V AC single phase), and a DMX signal cable. The LCD Display will turn on after the power switch is turned to "ON" position. Now you are ready to set the desired configuration and DMX addresses.

You can assign a DMX channel to control dimming, cooling fan speed, LCD display-on time, built-in effects and live/safe modes according to the DMX value on the "Menu Map". These parameters can also be assigned through a console.

CONTROL INTERFACE

LEO™ LED Zoom Ellipsoidal comes with a LCD Display and a control knob on the rear of the unit for control settings:

1. LED Temperature
2. DMX dimming address
3. Built-in effects
4. Cooling Fan speed control
5. Operation Mode: Live or Safe
6. LCD display on time
7. Control mode: DMX or Manual
8. DMX dimming address setting
9. Status-bar
10. Rotary-press-knob

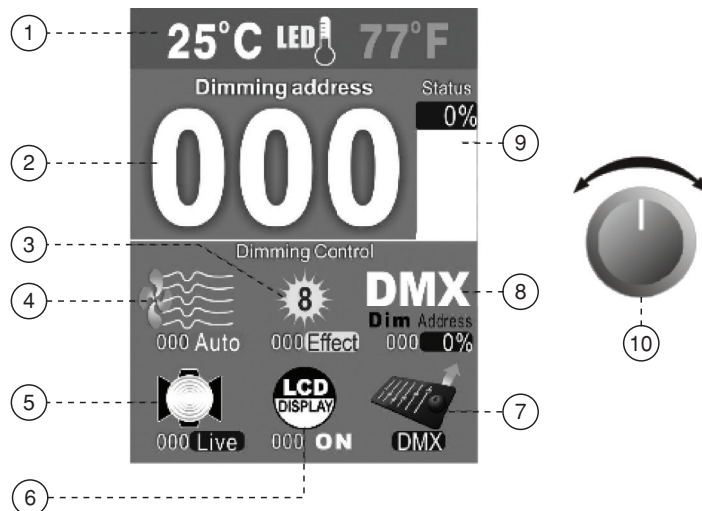

CONTROL BASICS

CAUTION:



Check the fuse before connecting power.

Connect power to the powerCON® connector at the rear side of LEO™ LED Zoom Ellipsoidal and switch the power switch to the "ON" position. The LCD display will turn on and the fixture is ready to operate. The fixture is defaulted for DMX control, press the rotary-press-knob once and rotate to move the cursor to the desired operation icon.

SETTING DMX ADDRESS OF THE FIXTURE

Move the cursor to DMX Dim Address (see figure on page 8, #8) and press the rotary-press-knob. The selected icon background will change to a red color. The DMX address for dimming the fixture can be changed by rotating the knob. A large 3-digit display (see figure on page 8, #2) and a small figure below the DMX address icon (see figure on page 8, #8) will show the DMX address simultaneously. Press once to confirm the selected number of DMX address. The background color then returns to normal.

Note: LEO™ LED Zoom Ellipsoidal requires only one DMX channel for dimming, and that is the minimum number of DMX channels needed for the fixture.

SETTING CONTROL MODE TO "MANUAL CONTROL"

Repeat the steps to move the cursor over the DMX icon (see figure on page 8, #7) and press once. The status-bar will appear "DMX" and "manual," rotate the knob to move the cursor over "manual" and press once.

The Manual icon will replace the DMX and the status-bar will appear "STD" and "FINE". Select "STD" for standard dimming (5 knob-rotations), and "FINE" for super fine dimming (about 13 knob-rotations).

Press once to confirm selection. The fixture is ready for manual dimming control. The percentage of local dimming will be shown at the status-bar. Press once to leave manual control mode.

SETTING THE TIME OF LCD DISPLAY-ON

Repeat the steps to select the LCD Display icon (see figure on page 8, #6) and press once. Rotate the knob to change the DMX address for remote control. Press once again to confirm DMX address and the status-bar will appear "Esc" and the on time of the LCD, rotate the knob to select and press again to confirm. Rotate the knob to move the cursor to "Esc" at the status-bar and press once to leave.

SETTING SAFE OPERATION MODE

CAUTION:



"Live" mode allows the LED light source to operate at over-temp conditions which might shorten the lifetime and even burn out the LED chip!

It is recommended to use the factory default "Safe" mode for normal operations.

Repeat the steps to select the fixture Operation Mode (see figure on page 8, #5) and press once. Rotate the knob to change the DMX address for remote control. Press once again to confirm DMX address and the status-bar will appear "Esc"/"Live"/"Safe" for selection. Rotate the knob to select Live or Safe mode. Press once to confirm mode selection or press "Esc" to return to main menu.

At Safe mode, LEO™ LED Zoom Ellipsoidal will limit the light output when the LED temperature rises above 149°F (65°C) in order to protect the LED light source from overheating. The light output will be the first priority when Live Mode is selected.

SETTING COOLING FAN SPEED

Repeat the steps to select the Cooling Fan Speed control (see figure on page 8, #4) and press once. Rotate the knob to change the DMX address for remote control. Press once again to confirm DMX address and the status-bar will appear "Esc"/"Auto" and "Speed 1" to "Speed 4". Auto fan mode is recommended in order to provide full cooling power for the fixture at all times. Select lower fan speed for lower fan noise operation. "Speed 1" to "Speed 4" represents 90%, 80%, 70% and 60% of full fan speed respectively. Press once to confirm selection or press "Esc" to return to main menu.

Note: By default the fan starts to operate in the slowest speed (60%) when LED temperature is detected at 95 °F (35 °C) or above to maintain the lowest fan noise. The cooling fan cannot be turned off as heat generated by the LED light source will affect the lifetime and performance of the fixture.

SETTING BUILT-IN EFFECTS

LEO™ LED Zoom Ellipsoidal has 8 built-in flashing and dimming effects for demonstration. Repeat the steps to select the built-in effects (see figure on page 8, #3) and press once. Rotate the knob to change the DMX address for remote control. Press once again to confirm DMX address and the status-bar will appear "Esc", and "Effect 1" to "Effect 8". Press once to confirm selection or press "Esc" to return to main menu.

CONTROL ATTRIBUTES AND DEFAULT SETTINGS

The LEO™ LED Zoom Ellipsoidal fixtures have several different control attributes. With the exception of the dimming attribute which must be assigned a DMX value for remote control, all other attributes may be manually set only at the fixtures, or, remote controlled from your DMX console. Therefore, from a DMX perspective, your fixture may be a 1, 2, 3, or 4 channel fixture depending on which attributes are assigned to a channel. Some customers will assign a unique DMX address for each dimming attribute, then, a common channel for all other attributes so fixtures are always controlled together. The system is flexible so the specific configuration is up to you.

Control Attribute		Value Range	Default Value	Options DMX Value	Level	Remarks
Dimming	Address	1-512	1			Mandatory to assign DMX channel to this attribute
Dimming mode	Option	0-2	0		0 1 2	Dimming according to DMX value Dimming according to manual knob Restore to factory setting
LCD display on time	Option	1-5	1	0-50 51-100 101-150 151-200 201-255	1 2 3 4 5	Continuously on LCD display off after 30 seconds LCD display off after 1 minute LCD display off after 2 minutes LCD display off after 3 minutes
LCD display on time	Address	1-512	0	0-255		
Operation mode	Option	0/1	1	0-127 128-255	0 1	Live: Light output will be the first priority Safe: LED over-temp protection, light output will be limited when temp. over 149°F (65°C)
Operation mode	Address	1-512	0	0-255		

DEFAULT SETTINGS

Menu Items		Value Range	Default Value	Options DMX Value	Level	Remarks
Fan speed	Option	1-5	1	0-50 51-100 101-150 151-200 201-255	1 2 3 4 5	Auto 90% of full speed 80% of full speed 70% of full speed 60% of full speed
Fan speed	Address	1-512	0	0-255		
Built-in effects	Option	0-8	0	0-20 21-40 41-70 71-100 101-130 131-160 161-190 191-220 221-255	0 1 2 3 4 5 6 7 8	Normal dimming Flash effect 1 – super fast Flash effect 2 – fast Flash effect 3 – medium Flash effect 4 – slow Fade-in & fade-out effect 1 Fade-in & fade-out effect 2 Fade-in & fade-out effect 3 Fade-in & fade-out effect 4
Built-in effects	Address	1-512	0	0-255		

MAINTENANCE

To eliminate unnecessary wear and improve its lifespan, during periods of non-use completely disconnect the product from power via breaker or by unplugging it.

EXPECTED LED LIFESPAN

LEDs gradually decline in brightness over time, mostly because of heat. Packaged in clusters, LEDs exhibit higher operating temperatures than in ideal, single-LED conditions. For this reason, using clustered LEDs at their fullest intensity significantly reduces the LED's lifespan. Under normal conditions, this lifespan can be 50,000 hours at 77 °F (25 °C). If extending this lifespan is vital, lower the operating temperature by improving the ventilation around the product and reducing the ambient temperature to an optimal operating range. In addition, limiting the overall projection intensity may also help to extend the LED's lifespan.

LENS

The lens in your fixture is made of a high quality glass and reflective coating which should require little maintenance. However, due to fog residue, smoke and dust, lens cleaning must be carried out periodically to optimize light output. To maintain optimum performance and minimize wear, clean this product at least twice a month. However, usage and environmental conditions contribute to increased cleaning frequency.

CAUTION:



Do not use ammonia-based or other harsh commercial cleaners. They may damage the glass surface and the Anti-Reflective coatings.

Replace lenses if they contain visible damage (cracks or deep scratches).

Step 1: Unplug the product from power and wait until the product is at room temperature.

Step 2: Open the lens compartment door by lifting the two spring clips on the top of the lens tube.

Step 3: Remove dust with a blast of oil-free air or wipe with a clean, lint-free cloth. Isopropyl alcohol may be used on the cloth.

Step 4: Make sure to dry all parts completely before plugging the product back in.

TRADEMARK DISCLAIMER

Use herein of third party trademarks, service marks, trade names, brand names and/or product names are for informational purposes only, are/may be the trademarks of their respective owners; such use is not meant to imply affiliation, sponsorship, or endorsement.

FOR CANADA ONLY

For warranty information and/or product returns, residents of Canada should contact Leviton in writing at Leviton Manufacturing of Canada Ltd to the attention of the Quality Assurance Department, 165 Hymus Blvd, Pointe-Claire (Quebec), Canada H9R 1E9 or by telephone at 1 800 405-5320.

WARRANTY INFORMATION

LEVITON LIGHTING & ENERGY SOLUTIONS DIVISION of Leviton manufacturing Co. Inc. warrants its Entertainment Products to be free of material and workmanship defects for a period of two years after system acceptance or 26 months after shipment, whichever comes first. This Warranty is limited to repair or replacement of defective equipment returned Freight Pre-Paid to Leviton Lighting & Energy Solutions Division at 20497 Teton Ave., Tualatin, Oregon 97062, USA. User shall call 1-800-959-6004 and request a return authorization number to mark on the outside of the returning carton, to assure that the returned material will be properly received at Leviton. All equipment shipped back to Leviton must be carefully and properly packed to avoid shipping damage. Replacements or repaired equipment will be returned to sender freight prepaid, F.O.B. factory. Leviton is not responsible for removing or replacing equipment on the job site, and will not honor charges for such work. Leviton will not be responsible for any loss of use time or subsequent damages should any of the equipment fail during the warranty period, but agrees only to repair or replace defective equipment returned to its plant in Tualatin, Oregon. This warranty is void on any product that has been improperly installed, overloaded, short circuited, abused, or altered in any manner. Neither the seller nor Leviton shall be liable for any injury, loss or damage, direct or consequential arising out of the use of or inability to use the equipment. This Warranty does not cover lamps, ballasts, and other equipment which is supplied or warranted directly to the user by their manufacturer. Leviton makes no warranty as to the Fitness for Purpose or other implied Warranties.

Leo is a registered trademark of Leviton Mfg. Co., Inc. in the U.S.A.:

LEO™



**LEVITON MANUFACTURING CO., INC.
LIGHTING & ENERGY SOLUTIONS DIVISION**

20497 SW Teton Avenue. Tualatin, OR 97062

Telephone: 1-800-736-6682 FAX: 503-404-559

Tech Line (6:00 AM-4:00 PM P.S.T. Monday-Friday): 1-800-959-6004

Email: lestechnsupport@leviton.com

Leviton Manufacturing Co., Inc.

201 North Service Road, Melville, N.Y. 11747

Telephone: 1-800-323-8920 • FAX: 1-800-832-9538

Information and specifications are subject to change without notice.

DISCARD ANY OLDER VERSIONS OF THIS USER'S GUIDE AND REPLACE WITH THIS VERSION.

Visit Leviton's Web site at <http://www.leviton.com>

© 2015 Leviton Manufacturing Co., Inc. All Rights Reserved