

Infrared Ceiling Mounted Occupancy Sensor

Cat. No. OSC04-R and OSC15-R

To be used with 24VAC/VDC OSPxx Series and CN100 Power Pack or other Class 2 power supplies

INSTALLATION INSTRUCTIONS



PK-93733-10-00-2A

WARNINGS AND CAUTIONS:

- **TO AVOID FIRE, SHOCK, OR DEATH: TURN OFF POWER AT CIRCUIT BREAKER OR FUSE AND TEST THAT POWER IS OFF BEFORE WIRING!**
- To be installed and/or used in accordance with appropriate electrical codes and regulations.
- If you are unsure about any part of these instructions, consult an electrician.
- Sensors must be mounted on a vibration-free surface.
- Do not terminate using data type wire, such as Cat 5/6E.
- All sensors must be mounted at least 6 feet away from air vents, air handlers, and reflective surfaces (windows/mirrors).
- Do not touch the surface of the lens. Clean outer surface with a damp cloth only.

CATALOG ITEMS					
Cat. No.	Description	Voltage Range	Current Consumption	HVAC Relay	Suggested Mounting Location
OSC04-R/W	High Density	15-28VAC/VDC	15mA DC, 30mA AC	Isolated Relay 1A @ 30VAC/VDC	450 sq. ft. Mount in center of room/area, 8-10ft height
OSC15-R/W	Extended Range	15-28VAC/VDC	15mA DC, 30mA AC	Isolated Relay 1A @ 30VAC/VDC	1500 sq. ft. Mount in center of room/area, 8-10ft height

FCC COMPLIANCE STATEMENT:

This device complies with part 15 of the FCC rules. Operation is subject to the following two conditions: (1) This device must not cause harmful interference, and (2) This device must accept any interference received, including interference that may cause undesired operation. Any changes or modifications not expressly approved by Leviton could void the user's authority to operate this equipment.

Tools needed to install your Sensor

Slotted/Phillips Pliers
Screwdriver
Pencil
Electrical Tape
Cutters

Parts Included List

Sensor (1)
#8-32 x 1/2 in. Screw (2)
#8-32 x 1-1/2 in. Screw (2)
#8-32 Washer and Nut (2)
Threaded Rod (1) and Hex Nut (1)
Half Mask (1)
360° Perforated Mask (1)
Plastic Washer (1)

DESCRIPTION

The Occupancy Sensor is a low-voltage infrared sensor that works with the OSPxx Series and CN100 Power Pack, or other Class 2 power supplies, to automatically control lighting. The sensor turns the lights on and keeps them on whenever occupancy is detected, and will turn them off after the "delayed-off time" has expired.

The sensor continually analyzes and adjusts to changing conditions. The sensor uses the latest microprocessor-based technology, which permits it to continually adjust and optimize its performance.

Infrared motion detection gives higher false triggering immunity that yields a sensor with excellent performance.

INSTALLING YOUR OCCUPANCY SENSOR

NOTE: Use check boxes when steps are completed.

Step 1 WARNING: TO AVOID FIRE, SHOCK, OR DEATH, TURN OFF POWER at circuit breaker or fuse and test that power is off before wiring!

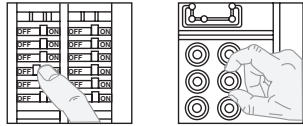

Step 2 Preparing and Connecting Wires:

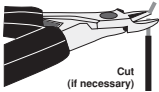

Strip Gage (measure bare wire here)
1/2 in. (1.3 cm)

Step 3 Typical Installations:

Listed are 3 typical installation options (A, B, and C). Choose one that best suits your needs. Other methods of installation may be possible, but they have not been described here.

A. Drop Ceiling Installation (Mounting Option A):

NOTE: Use the threaded rod included.

1. Select location for mounting of sensor and proper masking for your application (refer to Mounting Location Diagram).
2. Use the supplied threaded rod or other methods to make a hole (1/2 in. to 1 in.) in the ceiling tile, just large enough to pass the body of the threaded rod through.
3. Insert the sensor wires through the flared end of the threaded rod. Position the threaded rod to the base of the sensor.
4. Insert the flared end of the threaded rod into the opening in the bottom of the sensor and twist to lock into place.

Step 3 cont'd

5. Push the wires into the hole in the ceiling tile and insert the threaded rod until the sensor is flush with the tile.
6. Insert wires through the hole in the included washer and then place the included washer over the rod and screw on the included hex nut.
7. **Class 2 Wiring:** Connect low-voltage wires from power pack to sensor per WIRING DIAGRAM, as follows: Twist strands of each lead tightly and, with circuit conductors, push firmly into appropriate wire connector. Screw connectors on clockwise, making sure that no bare conductor shows below the wire connectors. Secure each connector with electrical tape.
8. Rotate the sensor to the desired orientation. Note that the sensor base and back cover are keyed. To lock the device in place, ensure that the arrows are not aligned.
9. Restore power at circuit breaker or fuse to power pack. **INSTALLATION IS COMPLETE.** NOTE: All wired connections to the sensor are Class 2 low-voltage.

Mounting Option Diagram A Occupancy Sensor Mounted to Drop Ceiling Using Threaded Rod

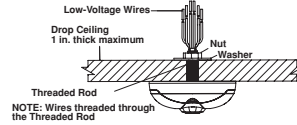

NOTE: Wires threaded through the Threaded Rod

B. Wallboard or Drop Ceiling Installation (Mounting Option B):

NOTE: You may use the mounting screws, nuts, and washers included, or screws in combination with commercially available wall anchors.

1. Select location for mounting of sensor and proper masking for your application (refer to Mounting Location Diagram).
2. Make a hole in the ceiling tile or wallboard, large enough to pass the wire connections and wire nuts through (approximately 1 in. diameter).
3. Remove the back cover of the sensor. Hold the back cover and body of the sensor and rotate until the two arrows line up and pull apart.
4. Install back cover of the ceiling sensor to the wallboard or drop ceiling using the included screws, nuts, and washers, or screws in combination with commercially available wall anchors.
5. **Class 2 Wiring:** Connect low-voltage wires from power pack to Sensor per WIRING DIAGRAM, as follows: Twist strands of each lead tightly and, with circuit conductors, push firmly into appropriate wire connector. Screw connectors on clockwise, making sure that no bare conductor shows below the wire connectors. Secure each connector with electrical tape.
6. Push wire connections through the center hole of the back cover and into the ceiling.
7. Secure the sensor body to the back cover by aligning the arrows. Lock it by turning the sensor such that the arrows do not line up.
8. Rotate the sensor to the desired orientation.
9. Restore power at circuit breaker or fuse to power pack. **INSTALLATION IS COMPLETE.**

Mounting Option Diagram B Occupancy Sensor Mounted to Wallboard or Drop Ceiling Using Screws

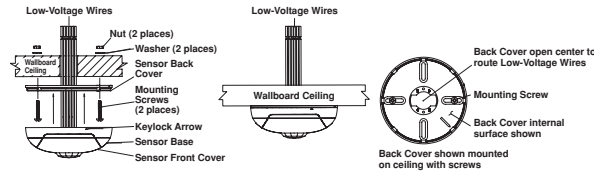

Back Cover open center to route Low-Voltage Wires
Back Cover internal surface shown
Back Cover shown mounted on ceiling with screws

Step 3 cont'd

C. Junction Box or Surface Mount Raceway Installation (refer to Mounting Diagrams):

NOTE: Listed below are suggested JUNCTION BOX installation applications, which require mounting to conduct in one of the following three ways:

Occupancy Sensor Mounted to Octagon Box Installed Flush to Wallboard Ceiling

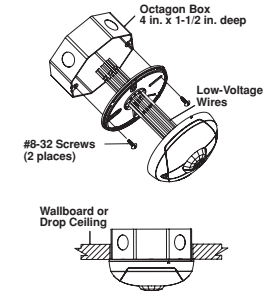

Step 3 cont'd

Occupancy Sensor Mounted to Round Fixture with Raceway for Wallboard Installation

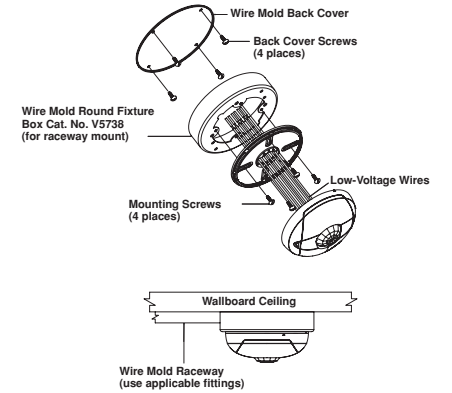

Wiring Diagram: Multiple Sensor, Single Power Pack

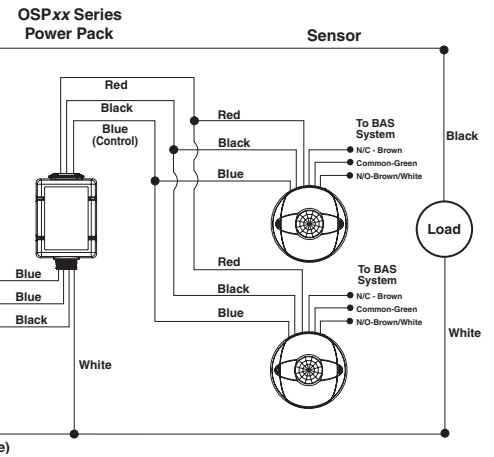

NOTE: Ensure to cap wires that are not being used.

WEB VERSION

OPERATION

Motion detection by the infrared sensor will turn on the lights, as well as keeping them on. When motion is not detected, the lights will turn off after the delayed-off time.

- **Delayed-Off Time** – The sensor is designed to turn the lights off if no motion is detected after a specified time. This length of time is called the “delayed-off time” and is set using the timer (Black) knob on the sensor. The adapting patterns will modify the delayed-off time to fit the parameters of each installation, based on environmental conditions and occupancy patterns.

- **Walk-Through Mode** – The “walk-through” feature is useful when a room is momentarily occupied. With this feature, the sensor will turn the lights off shortly after the person leaves the room.

The “walk-through” feature works as follows: When a person enters the room, the lights will turn on. If the person leaves the room before the default walk-through timeout of 2.5 minutes, the sensor will turn the lights off. If the person stays in the room for longer than 2.5 minutes, the sensor will proceed to the standard operation.

- **LED Operation** – There are two LED indicators that will flash when motion is detected. The LED flash can be disabled using the LED disable switch setting. Red flash indicates motion detection by infrared technology.

ADAPTIVE FUNCTIONS

The sensor continually analyzes the parameters of the motion detection signal and adjusts its internal operation to maximize detection of motion, while minimizing the effects of noise (electrical noise, air currents, temperature changes, etc.).

Operation:

When the lights turn on, the sensor initially enters the “walk-through” mode. Once the room is occupied for longer than 2.5 minutes, the sensor exits the “walk-through” mode and enters the “occupied” mode. When the sensor is first installed, the delayed-off time for the “occupied” mode is based on the time-adjustment settings. While the sensor is in use, the delayed-off time will change, based on how the sensor adapts to the room conditions. Whenever the sensor subsequently turns on, the value of the delayed-off time will be the adapted value (refer to **Occupancy Pattern Learning For Delayed-Off Time**).

The adapted settings can be reset using the DIP switch.

Occupancy Pattern Learning for Delayed-Off Time:

The sensor will automatically change the delayed-off time in response to the occupancy and environmental conditions of the space it is installed in. The sensor analyzes the motion signal properties and will minimize the delayed-off time duration when there is frequent motion detection, and lengthen the delayed off time duration when there is weak and infrequent motion detection.

In the case of a false-off condition (lights turn off when the room is occupied), the delayed-off time duration will immediately be lengthened to prevent further false turn-offs.

Occupancy Pattern Learning for Infrared Technology:

The sensor learns the occupancy patterns of a space during the course of a day, for a seven-day period. At any given time, the sensor will look at the collected data and adjust its infrared sensitivity. The sensor will adjust the sensitivity to make it less likely to turn on during a period of non-occupancy, and more likely to turn on during a period of occupancy.

SETTINGS

Adjustment knob settings as per “recommended manual settings” (refer to **Table 3 and Figure 1**).

All switches in the OFF position, except A4 is set to ON (refer to **Table 4**).

TABLE 3 : ADJUSTMENT KNOB SETTINGS				
Knob Color	Symbol	Function	Knob Setting	Factory Default Setting
Red		Sets the infrared range	Range Setting Full CCW = min. (OFF) Full CW = max.	75%
Black		Delayed-Off Time	Full CCW = min. (30 sec) Full CW = max. (30 min.)	50% (10 min)

TABLE 4: SWITCH SETTINGS				
SWITCH	SWITCH FUNCTIONS		SWITCH SETTINGS	
	Bank A		OFF	ON
A1	N/A		N/A	N/A
A2	N/A		N/A	N/A
A3	Manual Mode	Auto-Adapting Enabled	Auto-Adapting Disabled	
A4	Walk-Through Disable	Walk-Through Enabled	Walk-Through Disabled	
			Bank B	
			OFF	ON
B1	Override to ON	Auto Mode	Lights Forced ON	
B2	Override to OFF	Auto Mode	Lights Forced OFF	
B3	Test Mode	OFF → ON → OFF = Enter/Exit Test Mode		
B4	LEDs Disable	LEDs Enabled	LEDs Disabled	

Test Mode: Set the delayed-off time to 4 seconds for performing a walk-test. While the sensor is in “test” mode, the LEDs will flash amber once every 6-7 seconds.

1. **ENSURE POWER IS ON.**
2. Remove front cover.
3. Locate DIP Switch 3 in Bank B (B3) (refer to **Figure 1**). B3 will be in the OFF position from the factory.
4. To enter “test” mode, move switch to ON and back to OFF. The “test” mode has now been entered with a 4-second time-out. **NOTE:** If B3 is already in the ON position, then “test” mode can be entered by just moving it to the OFF position.

NOTES:

1. The timer will remain in 4-second “test” mode for 15 minutes and then automatically exit “test” mode and reset to delayed-off time setting, as defined by black timer knob.
2. To manually take the timer out of the 4-second test mode, simply toggle the switch B3 from OFF to ON and back to OFF.

Isolated Relay Operation:

The Isolated Relay supports HVAC and other Class 2 low-voltage signal lines up to 1A at 30VAC/VDC. It is a single-pole, double throw relay with Normally Open (N/O), Normally Closed (N/C), and Common wires. It follows occupancy such that the N/O wire is connected to Common during occupancy.

Mounting Height:

Recommended mounting height for standard lens (default lens on unit) is 8 feet.
Recommended mounting height for the mid-range lens (supplementary lens) is 8-20 feet.

Figure 1 - Minimum and Default Settings

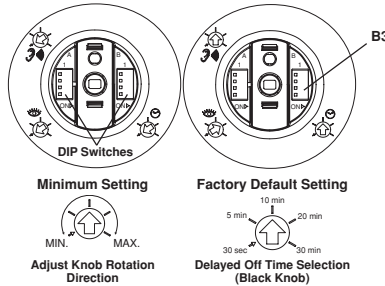

Minimum Setting



Adjust Knob Rotation Direction

Factory Default Setting



Delayed Off Time Selection (Black Knob)

Figure 2 - (Cat. No. OSC04) Field-of-View Ranges

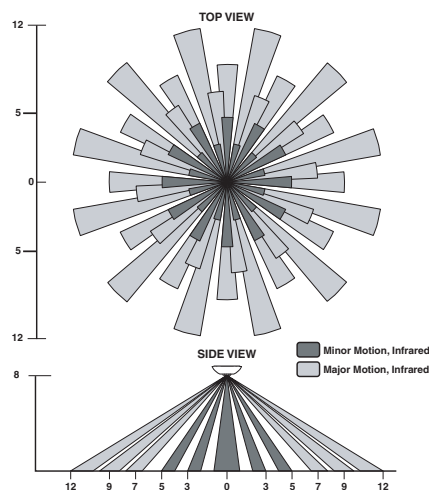

Figure 3 - (Cat. No. OSC15) Field-of-View Ranges

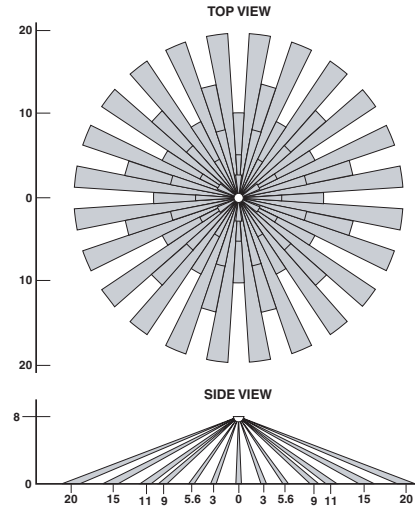
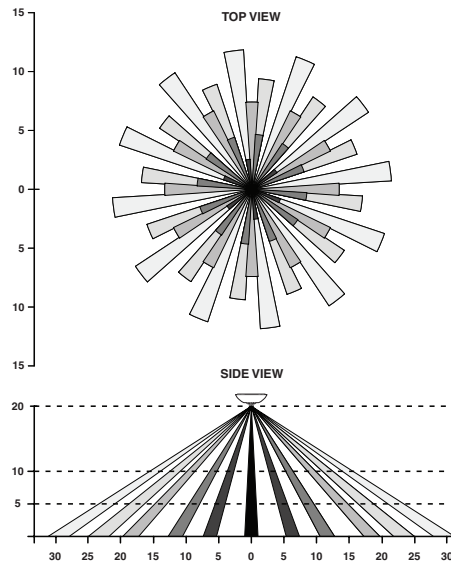
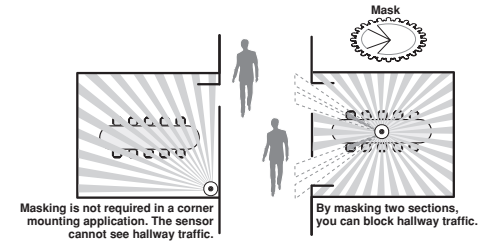

Figure 4 - (Mid-Range Lens) Field-of-View Ranges

Note: This lens is included with all PIR models.



Mounting Location Diagram



TROUBLESHOOTING

- **Lights do not turn ON.**
 - Circuit breaker or fuse has tripped.
 - Low-voltage miswired. To Test: Connect RED to BLUE wire at power pack to force lights ON.
 - Line voltage miswired. To Test: Connect BLUE to BLUE wire rays (of power pack) to force the lights ON.
- **Lights stay ON.**
 - Constant motion. To Test: Reduce RED knob by 15%; remove motion source. If unsatisfactory, move sensor.
 - Infrared sensor can “see” into hallway. To Test: Put sensor in timer “test” mode and walk down hallway. If lights continue to come ON, move sensor.
- **Light stays on for too long.**
 - Timer setting is too high. To Test: Check switch settings. Typical setting is 10 minutes.

PRODUCT INFORMATION

- For technical assistance, contact us at 1-800-824-3005.
- Visit our website at www.leviton.com

LIMITED 5 YEAR WARRANTY AND EXCLUSIONS
Leviton warrants to the original consumer purchaser and not for the benefit of anyone else that this product at the time of its sale by Leviton is free of defects in materials and workmanship under normal and proper use for five years from the purchase date. Leviton's only obligation is to correct such defects by repair or replacement, at its option. For details visit www.leviton.com or call 1-800-824-3005. This warranty excludes and there is disclaimed liability for labor for removal of this product or reinstallation. This warranty is void if this product is installed improperly or in an improper environment, overloaded, misused, opened, abused, or altered in any manner, or is not used under normal operating conditions or not in accordance with any labels or instructions. There are no other or implied warranties of any kind, including merchantability and fitness for a particular purpose, but if any implied warranty is required by the applicable jurisdiction, the duration of any such implied warranty, including merchantability and fitness for a particular purpose, is limited to five years. Leviton is not liable for incidental, indirect, special, or consequential damages, including without limitation, damage to, or loss of use of, any equipment, lost sales or profits or delay or failure to perform this warranty obligation. The remedies provided herein are the exclusive remedies under this warranty, whether based on contract, tort or otherwise.