

GreenMAX™ DRC 2 Port Analog Interface

Cat. No. DRID0-C02, DRID0-CB2



WARNINGS

- TO AVOID FIRE, SHOCK, OR DEATH; TURN OFF POWER AT CIRCUIT BREAKER OR FUSE AND TEST THAT POWER IS OFF BEFORE WIRING!
- To be installed and/or used in accordance with appropriate electrical codes and regulations.
- If you are unsure about any part of these instructions, consult an electrician.

CAUTIONS

- Use this device with copper or copper clad wire only.
- For indoor applications only.
- Save these instructions.

PK-A3289-10-00-0C

INSTALLATION INSTRUCTIONS

ENGLISH

Introduction

The GreenMAX DRC Low Voltage Analog Interface (AI) is designed to accept input from low voltage sources like occupancy sensors, switches, photocells, and other related systems, and to interface to other external systems via low voltage input.

WARNING: TO AVOID FIRE, SHOCK, OR DEATH; TURN OFF POWER at circuit breaker or fuse and test that power is off before wiring

DRID0-C02 Installation Options

Mount with one of the following methods:

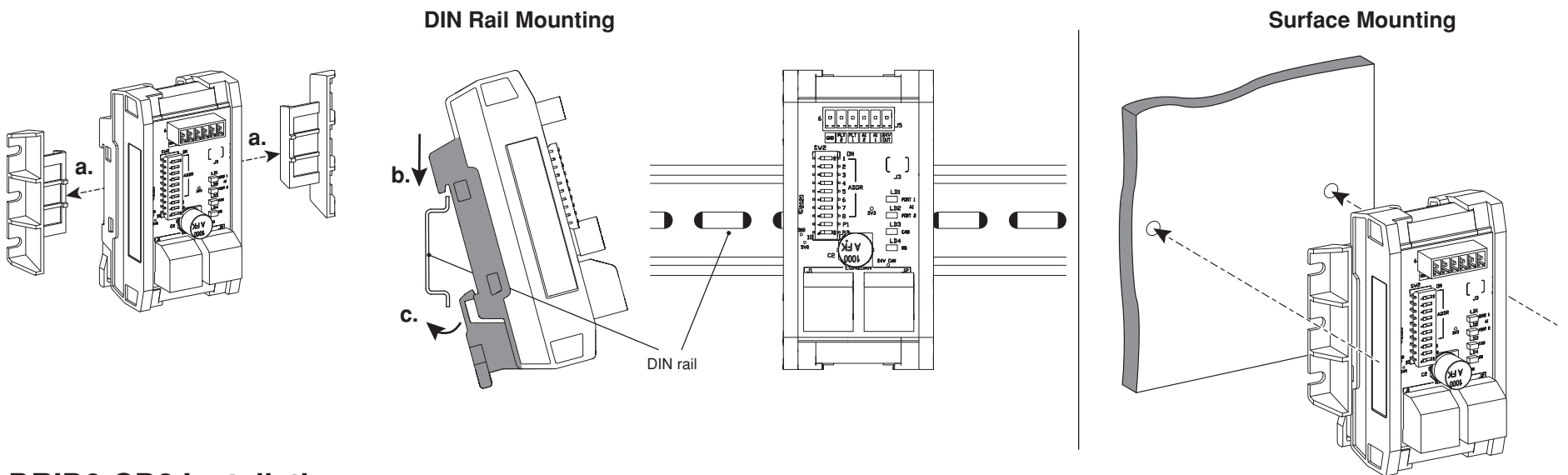

DRID0-CB2 Installation

Install into a 4-11/16 in. electrical junction box.

NOTE: Electrical junction box must have a depth of 2 in. or greater.

- a.** Feed wires through knockouts and wire device. Set unique LumaCAN network address. (refer to the **Wiring and Network Details** section).

- b.** Mount plate to junction box.

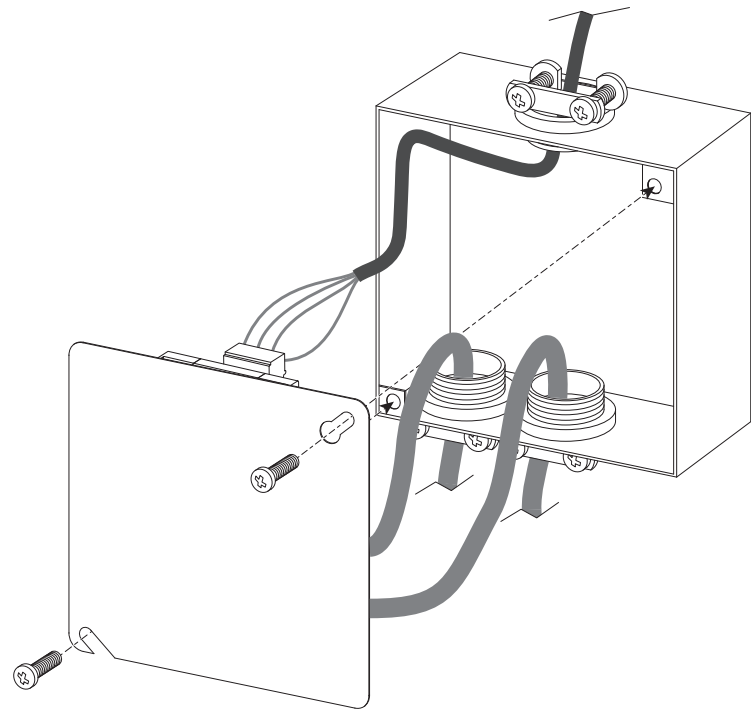
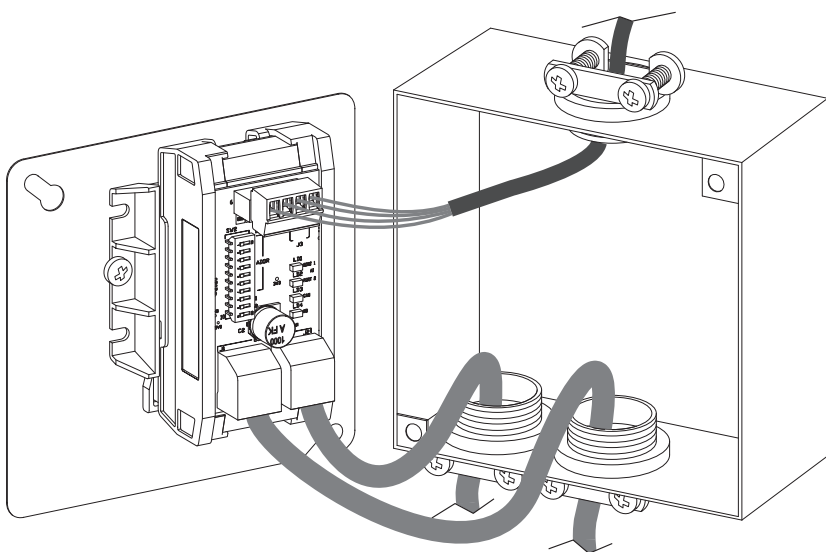

Interface

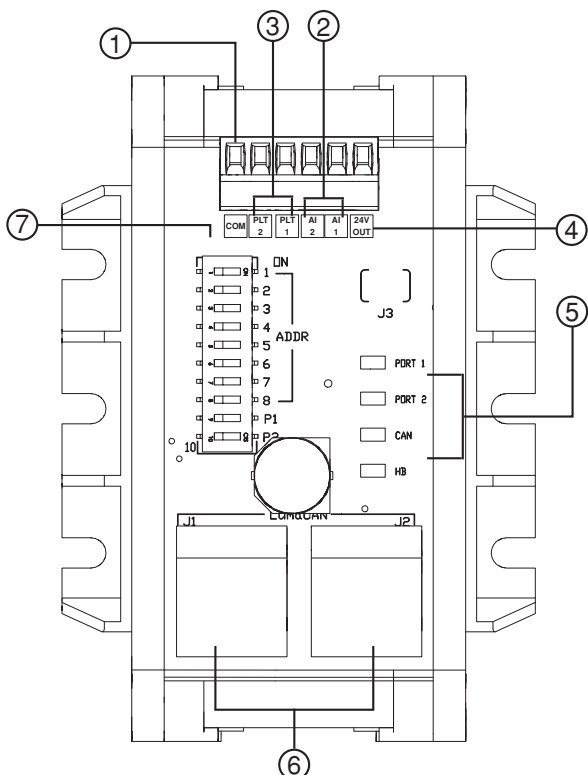

- 1. COM = COM**
- 2. AI1 & AI2 = Analog Input**
 - 0.5-24VDC at 10 bit resolution for analog inputs.
 - 0.5-10VDC for use with a photocell.
 - +24V/Open for external contact closure as you would use with a switch or a photocell contact closure. May be used with a momentary or maintained device.
- 3. PLT1 & PLT2 = Pilot Light.** Can be used to connect to external LED. These terminals are the "common" side of the indicator. Max sink current is 100mA across both PLT1/2. Output is driven by the system controller but will also blink slowly when an invalid LumaCAN address is assigned.
- 4. 24V OUT = Output voltage to devices.** Actual voltage will be same as input passthrough from LumaCAN.
- 5. STATUS LED = Shows network status.** The LEDs have the following functions:
 - AI1 = Solid Yellow when Analog Input #1 is Active (> 0.5V)
 - AI2 = Solid Yellow when Analog Input #2 is Active (> 0.5V)
 - AI1/AI2 = Blink rapidly when in bootloader mode.
 - AI1/AI2 = Blink slowly when a valid LumaCAN address is not assigned.
 - RX/TX = Solid Green when network connected. Blinks Green on network traffic.
 - All LEDs blink when overcurrent at the analog inputs have been detected by the device. User needs to remove the overcurrent condition to allow operation of the device.
- 6. LumaCAN = LumaCAN Network connections**
- 7. ADDR = Used to set LumaCAN network address.**

WEB VERSION

Wiring and Network Details

1. Wire the device and make all network connections. Some examples are shown, but your specific situation may warrant slightly different wiring. Refer to your submittal drawings or consult factory if you are unclear about connections means and methods.

NOTE: Devices are powered from the LumaCAN™ network and power is passed through the AI + 24Vout/COM terminals. Ensure you have adequate power to power all devices before connecting to the network.

NOTE: LumaCAN network must be powered by Class 2 or LPS power supply and total network power may not exceed 1500mA per power segment.

Wiring to a Single Photocell:

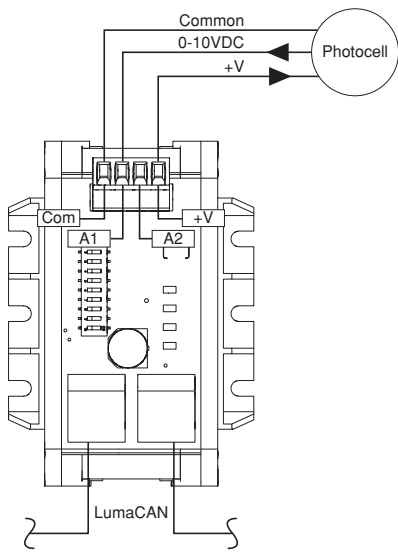

Wiring to a Demand Response Interface:

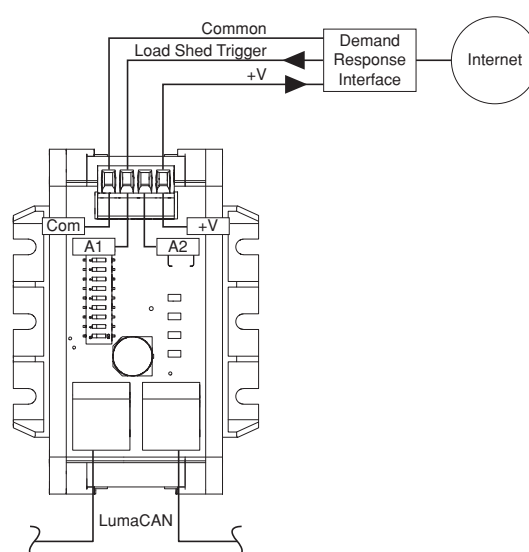

Wiring to Switch:

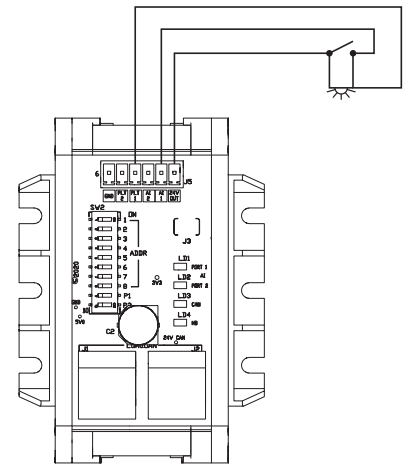

Wiring to (2) Occupancy Zones:

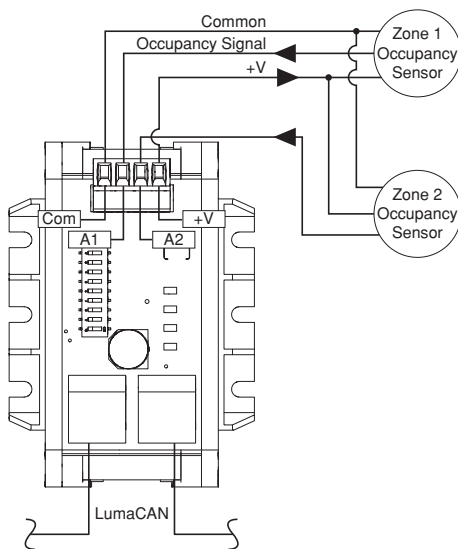

Wiring to (3) Occupancy Sensors:

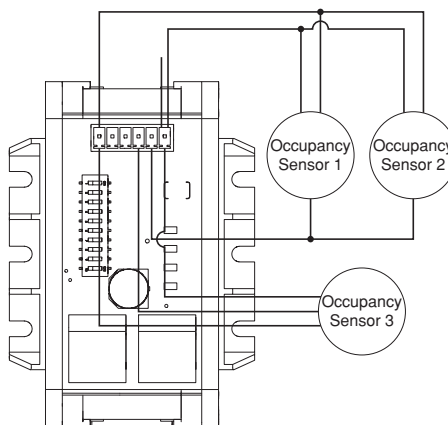

2. Set unique LumaCAN network address (see DIP switch designations below).

- All devices on a LumaCAN network require a unique address. This device supports Auto-Addressing which is the preferred method of address assignment.
- A GreenMAX DRC Room Controller will assign a unique address to all devices on the network.
- For Auto-addressing to work, all dip switches must be set to OFF.
- Both A1/AI2 LED's will blink when the device has no address, and, will stop blinking when a valid address is assigned.
- If you prefer to set an address manually, please use the dip switches to assign a fixed address.

ID Address Value = Sum of Switch Values
ID 86 = 2+4+16+64

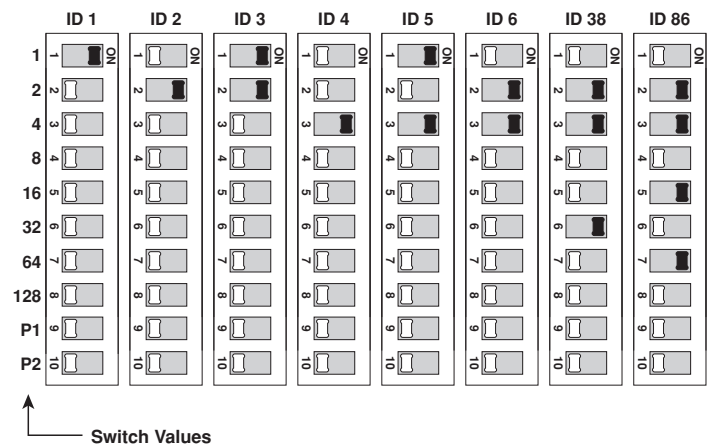

3. Program the analogue interface using a GreenMAX DRC room controller through the GreenMAX DRC System app.

Specifications	
Catalog Nos.	DRID0-C02, DRID0-CB2
Input Voltage/Frequency	+12-24VDC
Input Current	Powered from LumaCAN 45-22mA + Connected DC Load + Pilot Light Current
Output Voltage	Same as input voltage
Output Current	1.0A Max
IP Rating	00
Terminal Torque Rating, Low Voltage	1.8 lb-in
Network Connections	(2) RJ-45 Cat 6 or better for connection to LumaCAN network. Termination provided via local termination jumper.
Network Topology	<ul style="list-style-type: none"> Daisy Chain, 1600 ft. max between repeaters. Home-Run topology and network length up to 10,000 ft. can be achieved when using LumaCAN network repeaters (Leviton #NPRPT) Maximum 110 nodes between repeaters Maximum 250 nodes on a LumaCAN network
Operating Temperature	0-45°C
Storage Temperature	-10-70°C

Any changes or modifications not expressly approved by Leviton Manufacturing Co., could void the user's authority to operate the equipment.

FCC Statement:

This equipment has been tested and found to comply with the limits for a Class A digital device, pursuant to part 15 of the FCC Rules. These limits are designed to provide reasonable protection against harmful interference when the equipment is operated in a commercial environment. This equipment generates, uses, and can radiate radio frequency energy and, if not installed and used in accordance with the instruction manual, may cause harmful interference to radio communications. Operation of this equipment in a residential area is likely to cause harmful interference in which case the user will be required to correct the interference at his own expense.

IC Statement:

This device contains license-exempt transmitter(s)/receiver(s) that comply with Innovation, Science and Economic Development Canada's license-exempt RSS(s). Operation is subject to the following two conditions:

- This device may not cause interference.
- This device must accept any interference, including interference that may cause undesired operation of the device.

FCC SUPPLIER'S DECLARATION OF CONFORMITY:

Model DRID0-C02 and DRID0-CB2 are Sold by Leviton Manufacturing Inc. 201 N Service Rd, Melville, NY 11747.

This device complies with part 15 of the FCC Rules. Operation is subject to the following two conditions: (1) This device may not cause harmful interference, and (2) this device must accept any interference received, including interference that may cause undesired operation.

TRADEMARK DISCLAIMER:

The Leviton word mark and logo and the LumaCAN and GreenMAX trademarks, are the property of Leviton Manufacturing Inc., Co. Use herein of third party trademarks, service marks, trade names, brand names and/or product names are for informational purposes only, such use is not meant to imply affiliation, sponsorship, or endorsement.

FOR CANADA ONLY

For warranty information and/or product returns, residents of Canada should contact Leviton in writing at **Leviton Manufacturing of Canada ULC** to the attention of the **Quality Assurance Department, 165 Hymus Blvd, Pointe-Claire (Quebec), Canada H9R 1E9** or by telephone at **1 800 405-5320**.

LIMITED 5 YEAR WARRANTY AND EXCLUSIONS

Leviton warrants to the original consumer purchaser and not for the benefit of anyone else that this product at the time of its sale by Leviton is free of defects in materials and workmanship under normal and proper use for five years from the purchase date. Leviton's only obligation is to correct such defects by repair or replacement, at its option. For details visit www.leviton.com or call 1-800-824-3005. This warranty excludes and there is disclaimed liability for labor for removal of this product or reinstallation. This warranty is void if this product is installed improperly or in an improper environment, overloaded, misused, opened, abused, or altered in any manner, or is not used under normal operating conditions or not in accordance with any labels or instructions. There are no other or implied warranties of any kind, including merchantability and fitness for a particular purpose, but if any implied warranty is required by the applicable jurisdiction, the duration of any such implied warranty, including merchantability and fitness for a particular purpose, is limited to five years. Leviton is not liable for incidental, indirect, special, or consequential damages, including without limitation, damage to, or loss of use of, any equipment, lost sales or profits or delay or failure to perform this warranty obligation. The remedies provided herein are the exclusive remedies under this warranty, whether based on contract, tort or otherwise.

For Technical Assistance Call: 1-800-824-3005 (USA Only) or 1-800-405-5320 (Canada Only) www.leviton.com