

WARNINGS AND CAUTIONS:

- **DISCONNECT POWER AT CIRCUIT BREAKER OR FUSE WHEN SERVICING, INSTALLING OR REMOVING LUMINAIRE.**
- **DO NOT** control a load in excess of the specified ratings. Damage to the unit, fire, electric shock, personal injury or death can occur. Check your load ratings to determine suitability for your application.
- If you are unsure about any part of these instructions, consult an electrician.
- To be installed and/or used in accordance with electrical codes and regulations.

WARNINGS AND CAUTIONS:

- **DO NOT** install this unit to control a receptacle.
- The OSSNL-IFx Occupancy Sensor is intended to replace a standard light switch.
- Do not touch the surface of the lens. Clean outer surface with a damp cloth only.
- Use this device **WITH COPPER OR COPPER CLAD WIRE ONLY.**

TOOLS NEEDED TO INSTALL YOUR SENSOR

- | | | |
|------------------------------|-----------------|--------|
| Slotted/Phillips Screwdriver | Electrical Tape | Pliers |
| Pencil | Cutters | Ruler |

FEATURES

- Leviton's Decora® style design
- White LED NightLight function with Occupancy Sensor
- NightLight Activates when Low Ambient Light Present
- Adjustable NightLight Levels
- Auto ON/OFF (OSSNL)

DESCRIPTION

Leviton Cat. No. OSSNL-IFx, Designer Wall Switch Occupancy Sensor with LED NightLight, is designed to detect motion from a heat-emitting source (such as a person entering a room) within its field-of-view (monitored space) and either automatically or manually switches lights ON and OFF (OSSNL). The controlled lights will remain ON until no motion is detected and the scheduled time-delay has expired. The LED NightLight operates separately from controlled room lights and will turn ON via a photocell when the ambient light in the space is approximately less than 1 footcandle and turn OFF when the ambient light exceeds 5 footcandles. The LED NightLight is adjustable for continuous mode or a dim mode. In the dim mode the LED dims to approximately 5% of full brightness after 2 minutes of no occupancy. When in the manual ON switch mode, the LED NightLight will fade up and return to the adjustable setting when occupancy is detected and the ambient light level present to the photocell is less than 1 footcandle. The LED NightLight consumes less than one half of a watt providing energy savings and guide lighting when room lights are off. The LED NightLight output is fully adjustable with a simple dial setting.

OSSNL-IFx is perfect for use in hospitality and health care facilities with either auto ON or manual ON settings with adjustable time-delay settings of 30 seconds to 2 hours with LED NightLight. The OSSNL is UL listed and has a limited 5-year warranty.

PASSIVE INFRARED (PIR) TECHNOLOGY DESCRIPTION

The Occupancy Sensor senses motion within its coverage area of 1200 sq. ft maximum and controls the connected lighting. This is a self-contained device which provides sensing and light control. The Occupancy Sensor will turn the lights ON when motion is initially detected, and keep the lights ON for as long as motion is detected. The Occupancy Sensor uses a small semiconductor heat detector that resides behind a multi-zone optical lens. This Fresnel lens establishes dozens of zones of detection. The Sensor is sensitive to the heat emitted by the human body. In order to trigger the Sensor, the source of heat must move from one zone of detection to another. The device is most effective in sensing motion across its field-of-view, and less effective sensing motion towards or away from its field-of-view (refer to Field-of View diagrams). Keep this in mind when selecting the installation location.

Note that occupancy sensors respond to rapid changes in temperature, so care should be taken not to mount the device near a climate control source (i.e. radiators, air exchanges, and air conditioners). Hot or cold drafts will look like body motion to the device and will trigger it if the unit is mounted too close. It is recommended to mount the Occupancy Sensor at least 6 ft. away from the climate control source. The device can be mounted in a single gang wall box.

In addition, it is also recommended NOT to mount the Occupancy Sensor directly under a large light source. Large wattage bulbs (greater than 100W incandescent) give off a lot of heat and switching the bulb causes a temperature change that can be detected by the device. Mount the Occupancy Sensor at least 6 ft. away from large bulbs. If it is necessary to mount the device closer, lower the wattage of the bulb directly overhead.

INSTALLING YOUR SENSOR

NOTE: Use check boxes when Steps are completed.

Step 1 WARNING: TO AVOID FIRE, SHOCK, OR DEATH; TURN OFF POWER at circuit breaker or fuse and test that power is off before wiring!

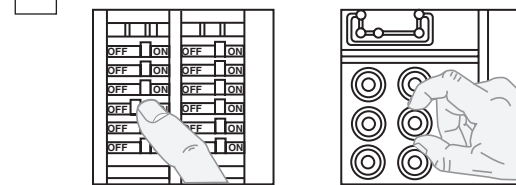

Step 2 Identifying your wiring:

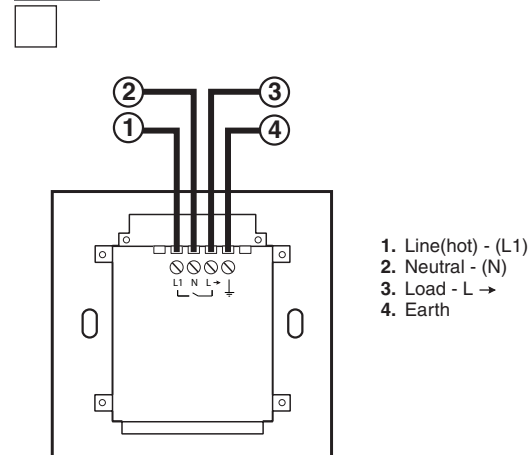

1. Line(hot) - (L1)
2. Neutral - (N)
3. Load - L →
4. Earth

Step 3 Preparing and connecting wires:

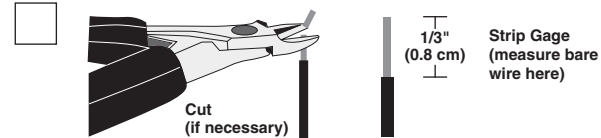

- Make sure that the ends of the wires from the wall box are **straight (cut if necessary)**.
- Remove insulation from each wire in the wall box as shown.
- Insert wire in proper terminal as shown below and tighten to 4kg-cm. Terminals will accept 3-.2mm² wire.

Step 4 Installing your Sensor - Single-Pole Application:

NOTE: Cat. No. OSSNL-IFx requires a neutral wire. If there is no neutral wire this device will not work.

NOTE: The Cat. No. OSSNL-IFx requires an Earthing wire bonded to the Neutral at the source to operate properly. If the Earthing wire is floating this device will not work.

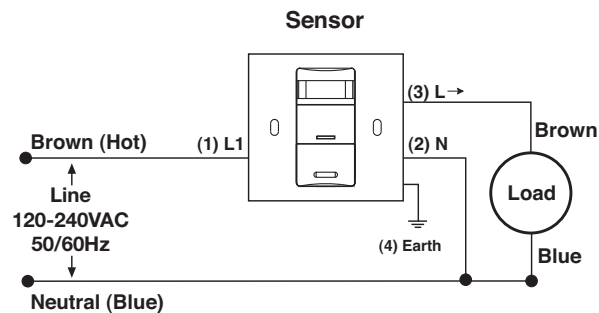

WIRING SENSOR:

Connect wires per WIRING DIAGRAM as follows: Insert wires into proper terminals and use a flat head screwdriver to turn terminal screws clockwise to secure wires.

- Green with yellow stripe in wall box to Earth terminal.
- Line Hot wall box wire to L1 terminal.
- Load wall box wire to L→ terminal.
- Line Neutral wall box wire to N terminal.

NOTE: Allow approximately 30 seconds for warm-up after connected.

Step 5 Testing your Sensor prior to completely mounting in wall box:

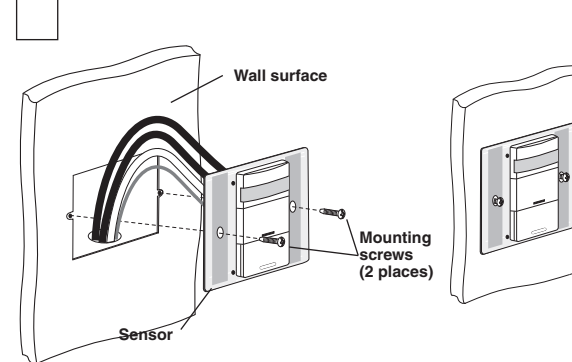

NOTE: Dress wires with a bend as shown in diagram to relieve stress when mounting device.

- Position all wires to provide room in outlet wall box for device.
- Partially secure device using long mounting screws provided.
- Restore power at circuit breaker or fuse.
- The LED indicator will flash after power is applied. Allow approximately 30 seconds for charge-up. After 30 seconds the lights will turn ON. If the lights turn ON and the LED blinks when a hand is waved in front of the lens, then the Sensor was installed properly.

If lights do not turn ON, refer to the TROUBLESHOOTING section.

NOTE: Cat. No. OSSNL-IFx is factory preset to work without any adjustments. If you desire to change the factory settings, refer to FEATURES AND SETTINGS section).

NOTE: To avoid PERMANENT DAMAGE to the unit, be careful NOT TO OVERTURN the control knobs or levers when setting the Sensor. The controls can be accessed by removing the wallplate (if applicable) and control panel cover (refer to Sensor Features Diagram). Use a small straight blade screwdriver to adjust knobs and blinder levers.

NOTE: DO NOT press in on blinder levers or use excessive force (refer to Sensor Features Diagram).

FEATURES AND SETTINGS:

BLINDERS: The blinders can narrow the field-of-view of the device to prevent unwanted activation from traffic in adjacent space. There are two blinders, and each operate independently. To operate the blinders, use a finger or small screwdriver to move the blinder adjustment levers toward or away from the center of the device.

The blinder levers are found above the control knobs and below the text 'BLINDERS' on the control panel. With both levers moved fully towards the center, the field-of-view is narrowed to 32°. With both levers moved fully away from the center, the field-of-view is at a maximum 180° (refer to Sensor Features Diagram).

Step 5 cont'd Testing your Sensor prior to completely mounting in wall box:

FEATURES AND SETTINGS:

TIME-DELAY: Cat. No. OSSNL-IFx will turn lights ON when motion is detected. When motion is no longer detected, the Sensor Unit will wait a certain amount of time and then turn the lights OFF. This wait time is called 'time-out'.

The "time-out" is selected from four (4) preset values. Pointing the arrow at one of the markings on the face chooses the value of time. The button LED indicator light will flash twice when the time setting has changed. The following selections are available:

OSSNL-IFx: Face Marking Value of Time

Face Marking	Value of Time
30S	30 second fixed time-out for performing a walk test
30M	30 minute time-out
1H	1 hour time-out
2H	2 hour time-out

NOTE: The "time-out" is factory preset to thirty (30) minutes (refer to Sensor Features Diagram).

NOTE: All time durations mentioned in the instructions are approximate within 10 seconds.

RANGE: To decrease detection range and sensitivity, rotate the knob counter-clockwise (refer to Sensor Features Diagram). The detections range can be adjusted from 100% down to 35%.

MANUAL-ON MODE: The factory default setting for the OSSNL is Manual-ON. To change this setting to Auto-ON/OFF, turn the dial marked "ON MODE/NL DIM" clockwise anywhere into the area that indicates "AUTO". To return to Manual-ON, turn the dial counter-clockwise anywhere into the area that indicates "MAN".

NIGHTLIGHT: The OSSNL-IFx responds to the ambient light level present in a room. The OSSNL-IFx uses an internal photocell to detect when the ambient light level is approximately less than 1 foot candle activating the LED NightLight. Further, the internal photocell will turn OFF the LED NightLight when it detects an ambient light level over 5 foot candles. The LED NightLight has adjustable light output to meet the needs of the space and can be set to for continuous mode or dim mode which will automatically dim to 5% of full brightness after 2 minutes of no occupancy.

NIGHTLIGHT DIM: To adjust the LED NightLight output, turn the dial marked "ON MODE/NL DIM" (OSSNL-INx) counter-clockwise to decrease and clockwise to increase light output.

NIGHTLIGHT MODE: The factory default setting for the NightLight Mode is dimmed mode. This means the LED NightLight automatically dims to 5% of full brightness after 2 minutes of no occupancy when activated by the internal photocell. To change the NightLight Mode perform the following procedure:

1. Press and hold the push button for 2 seconds to determine the current mode.
 - a. NightLight flashes once every 1 second for Continuous Mode until the button is released.
 - b. NightLight flashes twice every 1 second for Dim Mode until the button is released.
2. To change, hold the push button for 10 seconds and the Mode will toggle. This will be indicated by a change in the flash pattern as described above.

Sensor Features Diagram

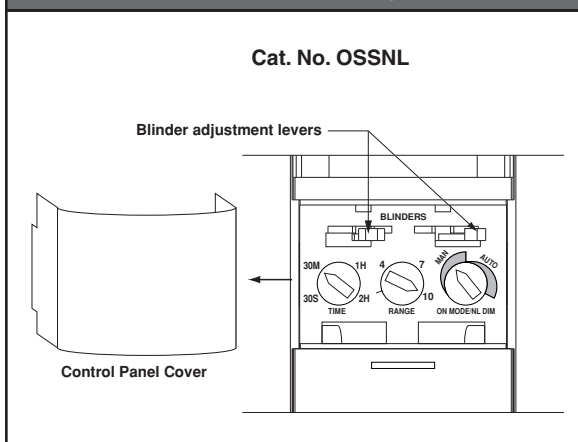

OPERATION

PUSH-BUTTON: Cat. No. OSSNL-IFx has a push-button switch that toggles the lights (**refer to figure**). If the lights are OFF, the lights will turn ON when the button is pressed, and remain ON in the presence of motion. In the absence of motion, the Sensor Unit will time-out and turn the lights OFF.

If the lights are ON, the lights will turn OFF when the button is pressed. The lights will stay OFF regardless of motion detected, until the time-out expires. After the time-out expires, the lights will turn ON (Auto-ON Mode only) with the next detected motion. This is useful for slide or film presentations.

NOTES:

- The Motion Indicator LED will blink every 2 seconds while motion is detected.
- In Manual-ON mode, the button must be pressed to turn the lights ON.

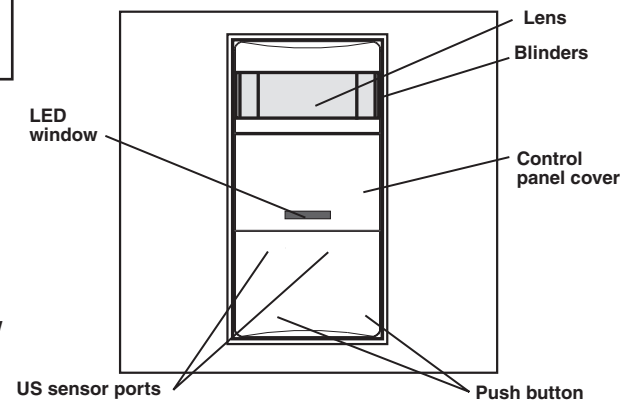

TROUBLESHOOTING

1. If there is no response from the unit (the light never turns ON and the LED never blinks) 1 1/2 minutes after power is applied, then uninstall device and verify there is an Earth connection at the wallbox. If there is an Earth connection, verify wiring.
2. If the lights never turn ON, but the LED blinks, check if the Manual-ON setting. See Manual-ON Mode setting for adjustments.
3. If the lights constantly stay ON, even when the room is unoccupied:
 - A. Check the Time setting. See how this time compares to how long the lights stay ON.
 - B. Try lowering the Range Control. Rotate the knob counter-clockwise about 30°.
 - C. If the problem persists, try reducing again. **NOTE:** Do Not reduce so much that Cat. Nos. OSSNL-IFx cannot see normal occupancy.
 - D. Be sure to use the Blinders to block any unwanted hallway traffic.
 - E. Check for reflected heat/motion as Sensor Unit may be seeing motion through a window.
 - F. Check for adjacent HVAC and/or heater ducts.

PRODUCT INFORMATION

- For technical assistance contact us at **1-800-824-3005**
- Visit our website at www.leviton.com

NOTES

NOTES

Step 7 Sensor and Wallplate Mounting:

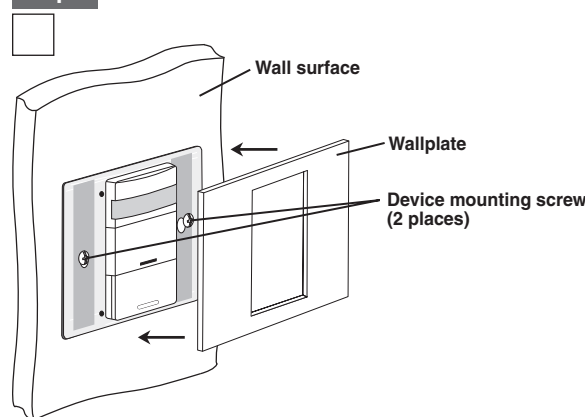

- Secure device by firmly tightening mounting screws.
- Install Decora® style wallplate (sold separately).

Field-of-View (Horizontal)

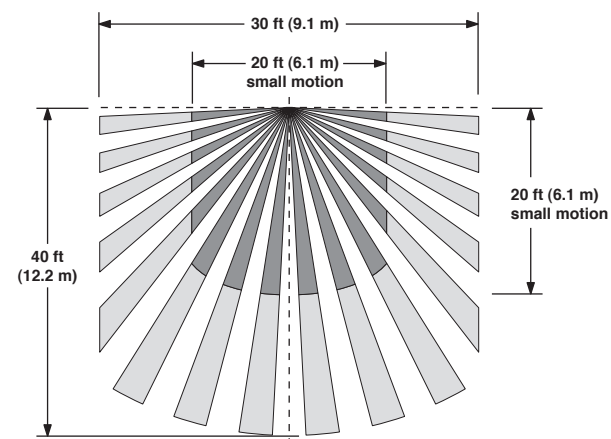

Side (Vertical) Field-of-View

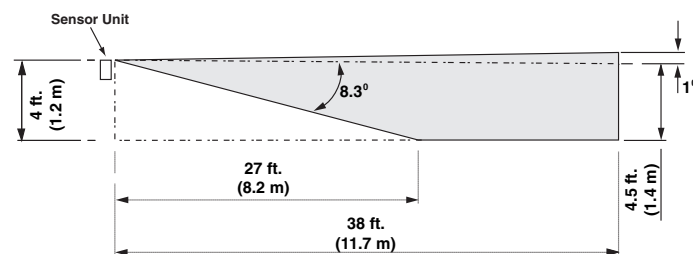

LIMITED 5 YEAR WARRANTY AND EXCLUSIONS

Leviton warrants to the original consumer purchaser and not for the benefit of anyone else that this product at the time of its sale by Leviton is free of defects in materials and workmanship under normal and proper use for five years from the purchase date. Leviton's only obligation is to correct such defects by repair or replacement, at its option, if within such five year period the product is returned prepaid, with proof of purchase date, and a description of the problem to **Leviton Manufacturing Co., Inc., Att: Quality Assurance Department, 201 North Service Road, Melville, New York 11747**. This warranty excludes and there is disclaimed liability for labor for removal of this product or reinstallation. This warranty is void if this product is installed improperly or in an improper environment, overloaded, misused, opened, abused, or altered in any manner, or is not used under normal operating conditions or not in accordance with any labels or instructions. **There are no other or implied warranties of any kind, including merchantability and fitness for a particular purpose**, but if any implied warranty is required by the applicable jurisdiction, the duration of any such implied warranty, including merchantability and fitness for a particular purpose, is limited to five years. **Leviton is not liable for incidental, indirect, special, or consequential damages, including without limitation, damage to, or loss of use of, any equipment, lost sales or profits or delay or failure to perform this warranty obligation.** The remedies provided herein are the exclusive remedies under this warranty, whether based on contract, tort or otherwise.

WEB VERSION