



THEATRICAL LIGHTING SOLUTION PACKAGE

Complete, versatile and cost effective

Stage Lighting Package Guide 400-900 Seat

As would typically be found in schools where theatrical production capability was desired within the auditorium/theatre

- The new all LED Theatre Lighting
- LEO LED Zoom Spotlights
- LEO LED Fresnel Spotlights
- LED Far Cyc
- LED Followspot
- Relay Power Control
- Retrofit Applications

DEEP STAGE LIGHTING FLOOR PLAN LAYOUT

Approximate Size : 45'-48' Wide Proscenium Opening x 48' Deep Stage

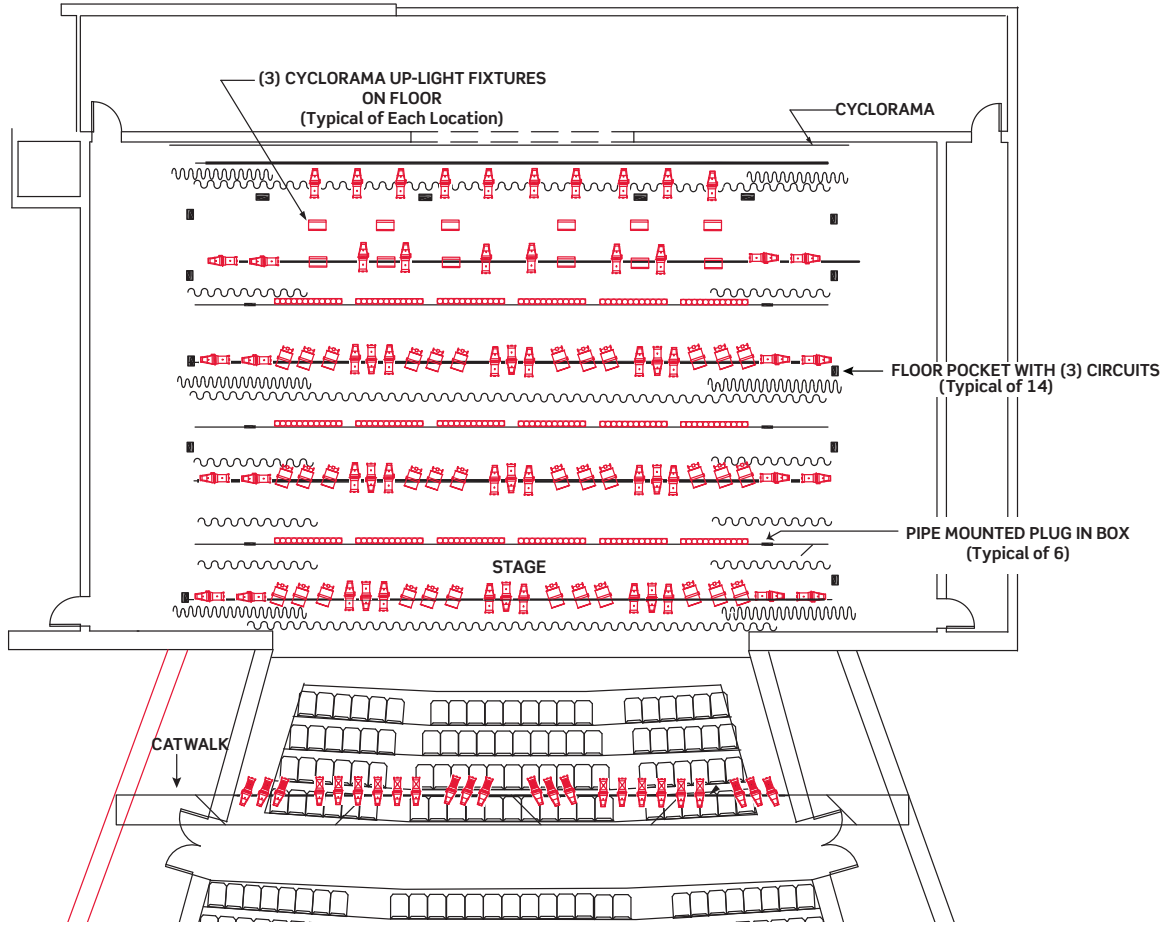

TYPICAL SECTION

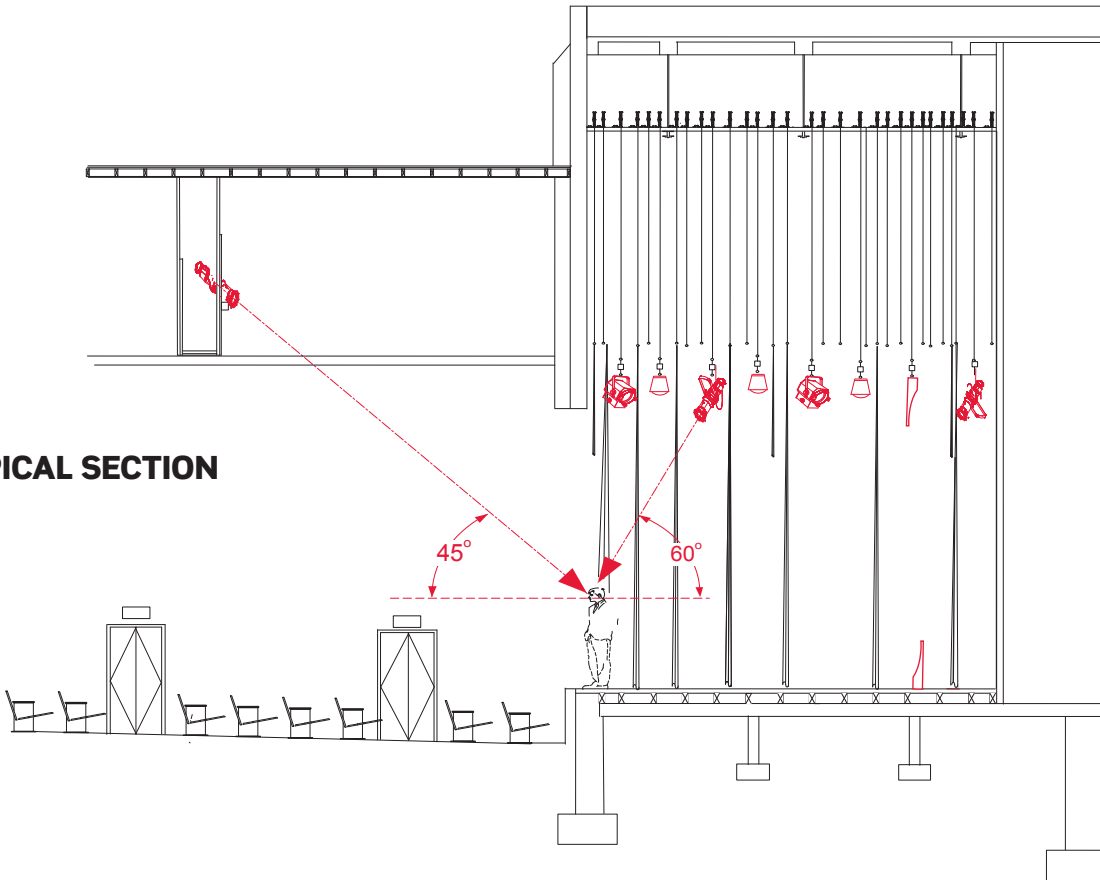

SYSTEM ONE LINE DIAGRAM

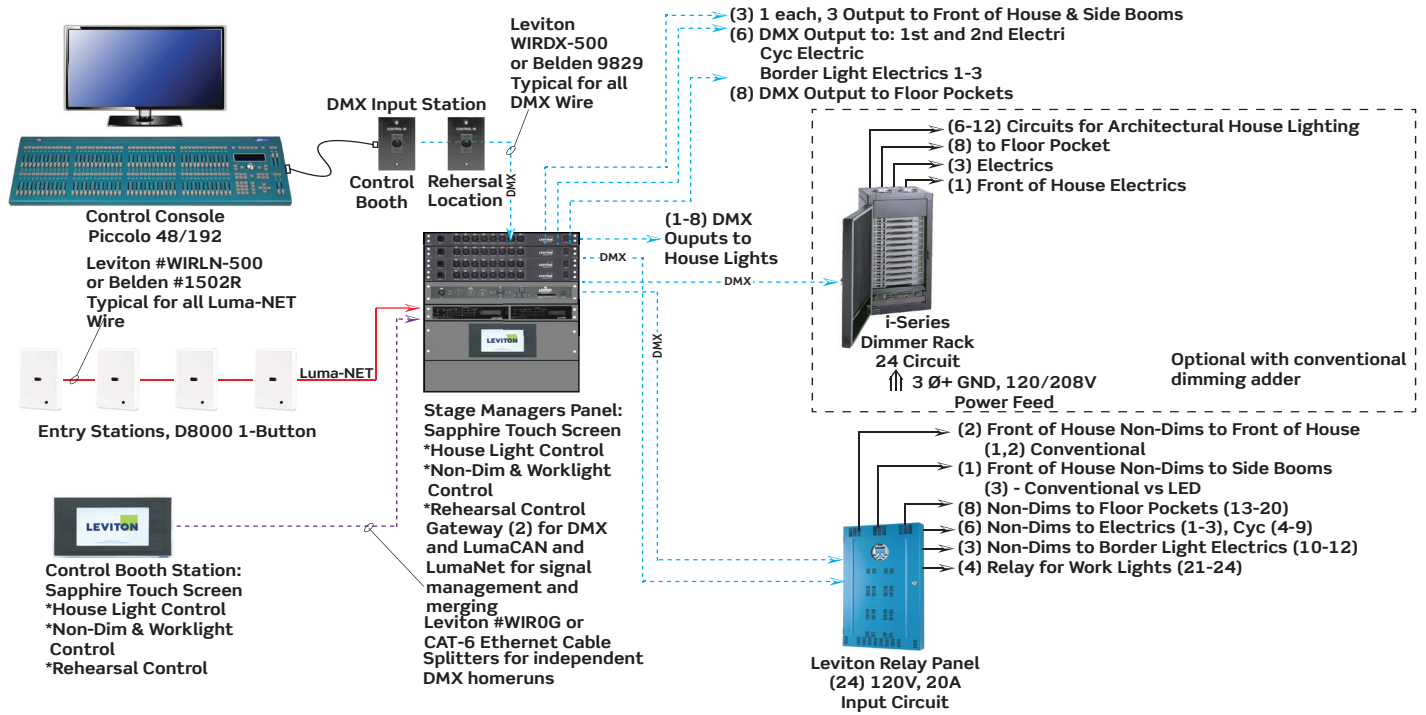

FIXTURE KEY

DEEP STAGE PACKAGE	SHALLOW STAGE PACKAGE	SYMBOL	DESCRIPTION	FUNCTION
12	12		LEO LED ELLIPSOIDAL SPOTLIGHT 8-22 DEGREE FIELD ANGLE	FRONT
46	34		LEO LED ELLIPSOIDAL SPOTLIGHT 18-36 DEGREE FIELD ANGLE	FRONT
25	14		LEO LED ELLIPSOIDAL SPOTLIGHT 30-55 DEGREE FIELD ANGLE	FRONT
36	24		LEO LED FRESNEL SPOTLIGHT	WASH & BACKLIGHTING
18	12		LED STRIP LIGHT	GENERAL STAGE WASH
6	6		LED CYC	BOTTOM CYCLORAMA & BACK DROP
6	6		LED CYC	TOP CYCLORAMA & BACK DROP
1	1		LED FOLLOWSPOT	SPECIAL FRONT LIGHT

BASE STAGE LIGHTING LAYOUT FLOOR PLAN

Approximate Size : 45'-48' Wide Proscenium Opening x 30' Deep Stage

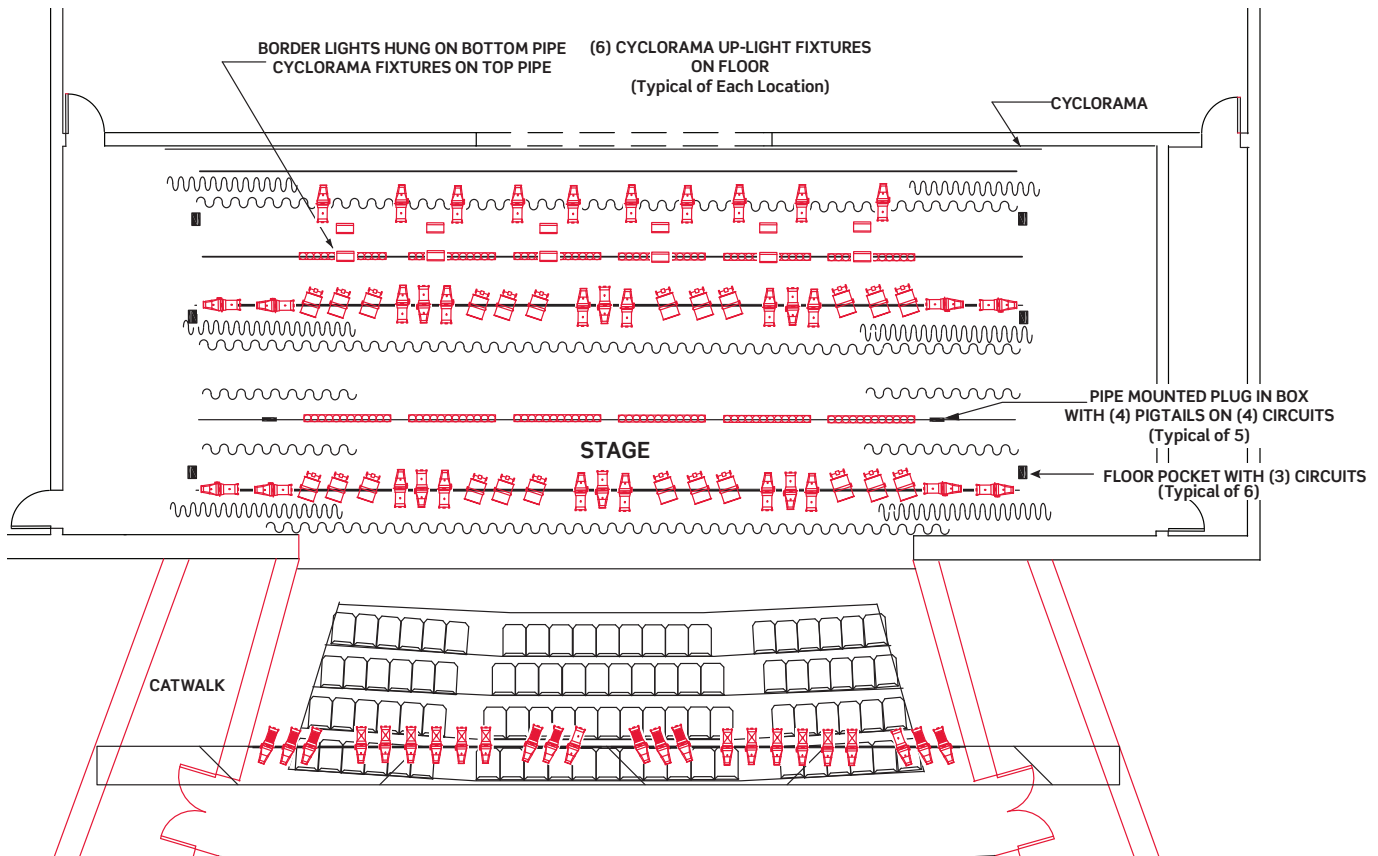

CONTROL STATION LAYOUT

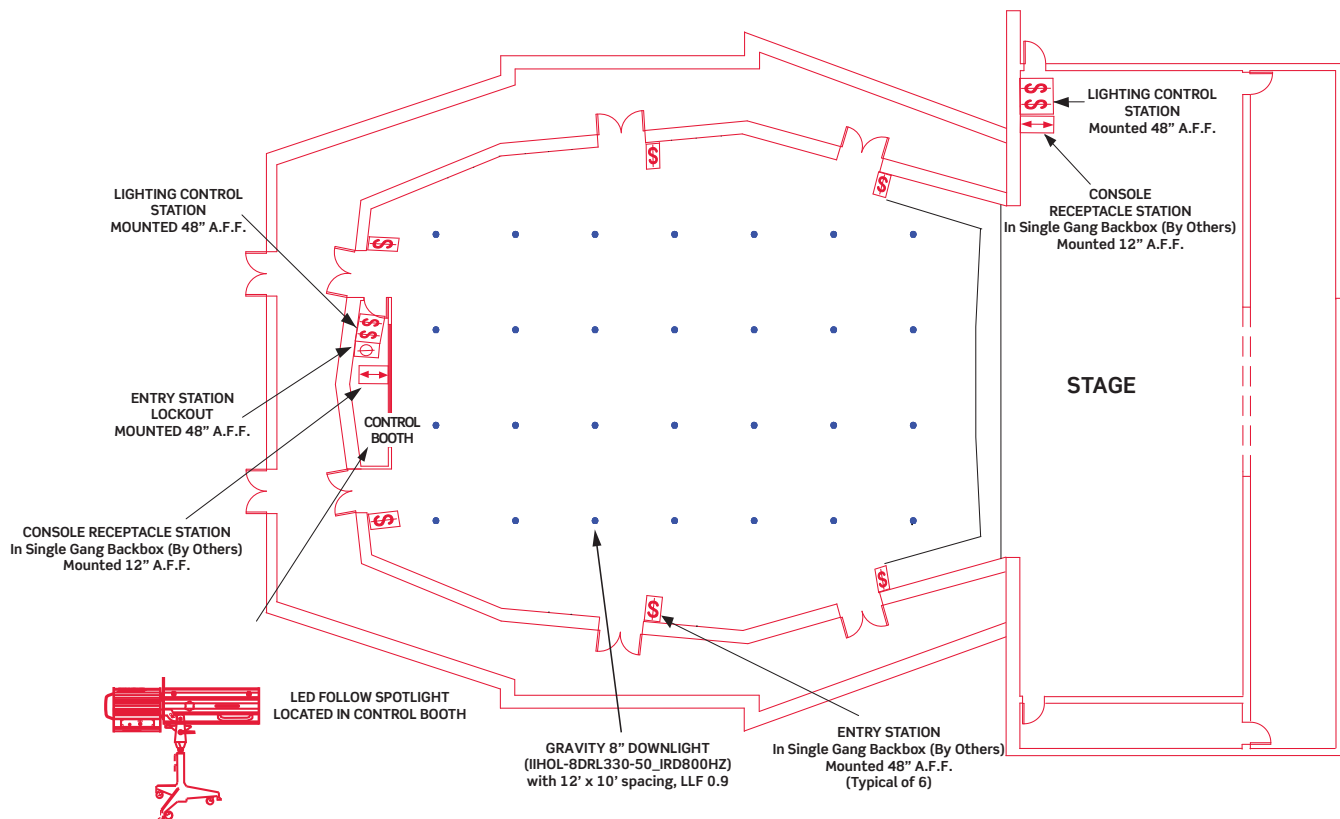

EQUIPMENT INFORMATION

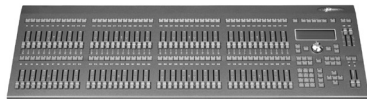

This guide is intended to illustrate a lighting system capable of providing basic stage lighting for a large theatrical facility or school auditorium. This particular selection and layout represents a balance between professional quality and budgetary considerations. The package can be ordered as is, or modified as required to suit specific applications.

The following products are used in these packages:

DIMMER RACK

iSeries Dimming Racks - these professional grade dimming racks offer control of up to (96) 20A circuits using high-density, professional grade dual dimmer modules. The dimmers in the rack can be controlled by either the theatrical control console or house/ stage lighting control stations.

RELAY PANEL

DMX Relay Panel - utilizing robust single 30A relays, 2 pole relays upon request. Product includes support not only for DMX control, but, low voltage and digital remote switches for dedicated control of worklight circuits

CONTROL CONSOLE

The Piccolo Console functions as a quick-to-learn manual two scene or full function preset memory board with automatic playback. Additionally (32) attribute channels are available for operating automated lighting devices.

ARCHITECTURAL/STAGE LIGHTING CONTROL

Sapphire™ LCD Touch Screen - provides flexible lighting controls in a variety of settings with a fully customizable user interface and the convenience of native controls.

Dimensions D8000® - D8000 is an advanced line of ale, complex projects that integrate theatrical, architectural and energy management lighting control systems.

POWER DISTRIBUTION EQUIPMENT

Connector Strips - These wireways provide power outlets along the fixture mounting pipes. Each outlet is labeled with its dimmer rack circuit number.

Plug-In Boxes - Floor, wall, and pipe mounted plug-in boxes with up to (6) outlets with circuit labels. Each provided with mounting hardware appropriate to the application.



FIXTURES

8" LED Fresnel - This 100W white light output fixture offers a "soft" quality of wash light with control of beam diameter from narrow to wide. Generally used for shorter throws. In this application it is being used for stage wash lighting from overhead lighting pipes.

LEO LED Zoom - This high lumen output, white LED profile unit provides excellent definition and shape control over the beam pattern and focus. In this application the fixture is being used as a front light for longer throw applications. The unit also has the ability to project picture gobo images.

Far Cyc LED Cyclorama Backdrop Light - Advanced multi-color mixing system. Provides a high intensity, asymmetrical light with a choice of RGBW or pure white. The cyclorama is often used to represent an exterior scene and is lit blue. Careful placement coupled with the asymmetric reflector design gives the even field required to accomplish the task.

LED Followspot - Exceptional performance with a highly engineered optical system. Clean, white beam with an optical zoom from 9-19 degrees. The unit features a front mounted 5-color changer and gobo holder to project images.

LED Strip Lights - 0-100% smooth dimming produces a soft and even field of asymmetrical light with a choice of RGBW or pure white. Simple and intuitive local control panel for setup, control and addressing.

PACKAGE BILL OF MATERIAL

	PRODUCT DESCRIPTION	Part Number	Base Package Qty	Extended Fixture Package Additional Qty	Wireless DMX Option Qty	Conventional Dimming Adder Qty		
DIMMING	i Series E Dimmer Rack supporting up to (12) modules	IER24-130	—	—	—	1		
	i Series E Dimmer Module, 2-Circuit, 120VAC, 20A	IED23-120				12		
	Air Flow Module	IEA40-00				—		
	Z-Max DMX Relay Cabinet (24) Relay Cabinet, 120V and 27V Input	R24DD-L24				1		
CONTROLS	Piccolo 48/192 Control Console with support for 192 channels and 256 attributes and Control Cable and Video Card	PPICO-V48	1	—	—	—		
	19" Flat Monitor	TAMON-F19	1			—		
	DMX Splitters	DMXSM-H18	1			3		
	Installation Rack for DMX Splitters	EIA00-S01	1			—	—	—
	Sapphire Touch Screen	TS007-000	2					
	Dimensions D8000 Single Gang Push Button Stations	KB010-00W	4					
	Luma-Net, LumaCan Gateway	NP00G-000	2					
	SMP Panel 12 Pcs		1					
	Rack Mount Sapphire Panel	Custom	1					
	Blank Panel	As needed	1					
POWER DISTRIBUTION	Dropbox (1) Non-Dim circuit and (1) DMX output	Custom	3	—	No DMX			
	Dropbox (2) Non-Dim circuits, (1) Dimmer, (1) DMX Output and (1) Worklight		3			—		
	SO Cable for up to (3) Power Circuits and (10 DMX Output, 100'		6			—		
	Plug box, (1) Non-Dim Circuit and (1) DMX Output		3			—		
	Floor Pocket Plugging Box with (3) Flush Mounted Receptacles, (1) DMX Output and labels		6			8	No DMX	—
FIXTURES	LED LED Ellipsoidal Light Engine, 3200K	LED00-30B	38	12	—	—		
	LEO LED Lens Tube, Zoom 8-22°	LED08-LTB	8	—				
	LEO LED Lens Tube, Zoom 18-36°	LED18-LTB	18	4				
	LEO LED Lens Tube, Zoom 30-55°	LED30-LTB	12	8				
	LEO LED Fresnel, 100W, 3200K	LFD10-30B	24	12				
	LED Followspot	LEDFS-xxxx	1	—				
	Altman Spectra Strip	STRx-xx-xxxx	24	—				
LED Cyclorama Light	LWCYC-00B	12	—					
WIRELESS DMX OPTION	C-Clamp	TAOCC-000	142	36	—	—		
	Color Frame, Black, 9.65" (245mm) for LEO LED Ellipsoidal and LEO LED Fresnel	LEDAC-CFB	Quantities Vary	Included				
	B Size Pattern Hold for LEO LED Ellipsoidal	LEDAC-PTN						
	Safety Guard, Black, 9.65" (245mm) for LEO LED Ellipsoidal and LEO LED Fresnel	LEDAC-SGB						
	8-Leaf Rotating Barn Door, 7.5" (190mm) for 100W LEO LED Fresnel	LFD10-BDB						
	Color Frame, 7.5" (190mm) for 100W LEO LED Fresnel	LFD10-CFB						
	Safety Guard, 7.5" (190mm) for 100W LEO LED Fresnel	LDF10-SGB						
	Safety Cables	TA0SC-000						
	Heavy Duty Followspot Tripod, black	LEDFS-STD						
	Heavy Duty Wheels for Followspot Tripod, black	LEDFS-STW						
	Boom Base Stand - 50 lbs, 1-1/2" pipe	CTP-157-349						
	14' Pipe Boom with Eye	BOI-PB14		—				
	24" Double Side-Arm	CTP-15-214						
	25' DMX Extension Control Cable	DMX5P-025		12			0	
	10' DMX Extension Control Cable	DMX5P-10		24			30	
	3' DMX Extension Control Cable	DMX5P-03		60			6	
	DMX Input Wall Plates	CPT-7-4011		Quantities Vary				
	PowerCon Extension Cable, Black, 5'/1.5M long	CTP-6-9205		Quantities Vary				
	PowerCon Extension Cable, Black, 15'/4.6M long	CTP-6-9210		Quantities Vary				
	PowerCon Extension Cable, Black, 25'/7.6M long	CTP-6-9215		Quantities Vary				
100 Sheets Lee Color Media - Assorted Colors	BOI-LEE100	Quantities Vary						
WIRELESS DMX OPTION	DMX Transmitter option for Piccolo Scan Console	WRCMX-C1T	—	—	1	—		
	DMX Receiver	WRCMX-I1R	—	—	11	—		
HOUSE LIGHT	8" Gravity Down Lights	IHOL-8DR	28	—	—	—		
	Wall Wash	IHOL-BWR	—	—	—	—		
	Recessed Lights	ICRLx	—	—	—	—		

Leviton Manufacturing Co., Inc. Energy Management, Controls and Automation

20497 SW Teton Avenue, Tualatin, OR 97062 tel 800-736-6682 fax 503-404-5594 tech line (6:00AM-4:00PM PT Mon-Fri) 800-959-6004

Leviton Manufacturing Co., Inc. Global Headquarters

201 North Service Road, Melville, NY 11747-3138 tel 800-323-8920 fax 800-832-9538 tech line (8:30AM-7:00PM ET Mon-Fri) 800-824-3005

Visit our Website at: www.leviton.com/entertainment

©2018 Leviton Manufacturing Co., Inc. All rights reserved. Subject to change without notice.

G-8559A/A18-aa