

rhino-hide®

16 Series Single Pole Cam-Type Panel Mount Receptacles with .75" Extended Shoulder

Type 3R Rated for Indoor/Outdoor Use
 For Applications up to 400 A, 600 V
 90°, 1.25" Threaded Stud, Taper Nose



Common Applications

- Construction Sites
- Mining Operations
- Entertainment Productions
- Sporting Events
- Conventions

Ordering Information

	Color	Male	Female
Order ID	Black	16R31-XE	16R32-XE
	White	16R31-XW	16R32-XW
	Red	16R31-XR	16R32-XR
	Blue	16R31-XB	16R32-XB
	Green	16R31-XG	16R32-XG
	Yellow	16R31-XY	16R32-XY
	Orange	16R31-XO	16R32-XO
	Brown	16R31-XH	16R32-XH

Specifications

Electrical Specifications	
Max. Amperage	400 A
Max. Voltage	600 V
Material Specifications	
Sleeve Material	Santoprene TPV
Contact Material	Brass
Strain Relief	Copper Wire

Mechanical Specifications	
Connection Type	Threaded Stud
Cable Range	#2 - 4/0 AWG
Standards & Certifications	
NEMA Rating	Type 3R
UL	1691

Dimensions

Male Panel Receptacle

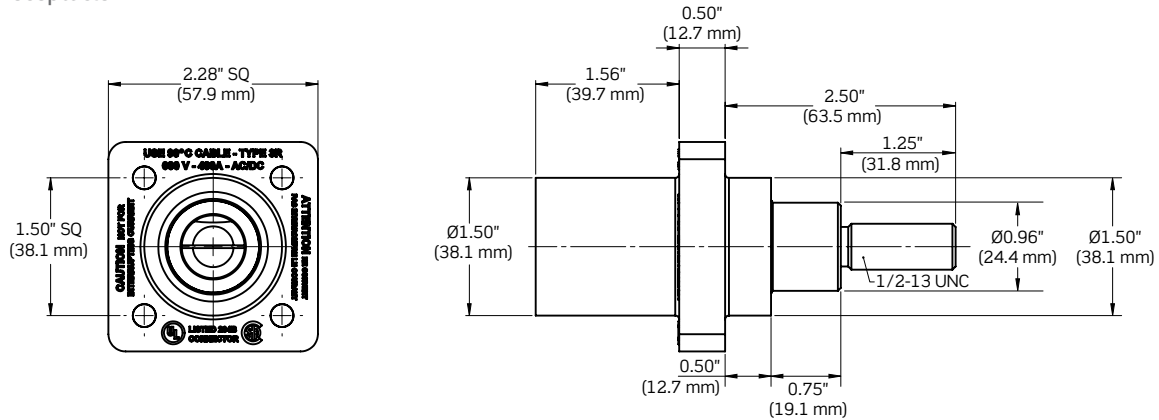

Female Panel Receptacle

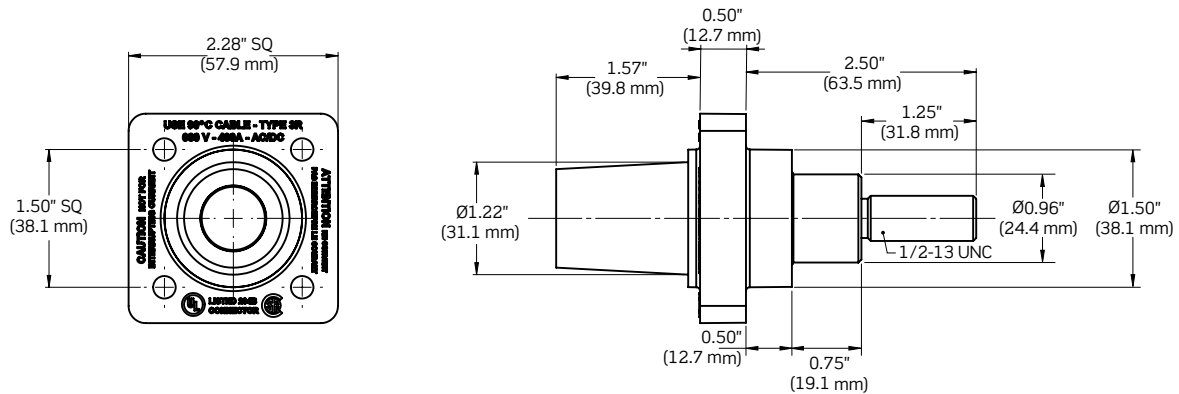

Visit our Website at:

www.leviton.com/industrial

email: industrial@leviton.com

Q-1143

042218

Leviton Manufacturing Co., Inc.

201 N Service Rd, Melville, NY 11747

Telephone: 1-800-323-8920 • FAX: 1-800-832-9538

Tech Line (8:30AM-7:30PM E.S.T. Monday-Friday): 1-800-824-3005

© 2018 Leviton Manufacturing Co., Inc. All rights reserved.

