

# Floor Boxes

Suitable for wood frame construction with carpet, wood, tile, and vinyl finished flooring\*

Meets or Exceeds  
UL514A Requirements  
Including Scrub Water  
Test

## Now Available in 2-Gang Configurations!

### Key Features

- Brass plate and screw cap resist abuse and prevent foreign contaminants from entering device
- Tamper-Resistant Receptacles meet National Electrical Code® 2014 Article 406.12 requirements
- Plate gasket and rubber O-ring combine to seal out moisture and air-borne particles
- Single receptacle is ideal for applications that require a dedicated circuit
- Meets NEC 2014 Article 314.27B for Floor Boxes
- The flange height of 0.27" meets Americans with Disabilities Act (ADA) standards for accessible design section 4.3.8
- Nickel-plated brass configurations also available
- Low-Voltage 2-gang configurations compatible with the QuickPort® line of audio/visual connectors and adapters

### Each Floor Box includes the following:

- Cover Plate with Screw Caps
- Heavy-Duty Specification Grade Receptacle(s)
- Duplex QuickPort® Insert (where specified)
- UL Listed 3-1/2" Deep Electrical Box
- Associated Mounting Hardware & Gaskets



### Common Applications

- Residential
- Health Care Facilities
- Great Rooms
- Conference Rooms
- Stages

\*Not for use with concrete flooring.

## Ordering Information

Description		Finish	1-Gang		2-Gang	
			15 Amp	20 Amp	15 Amp	20 Amp
Tamper-Resistant	Single Receptacle Floor Box, 1 Single Receptacle	Brass	5249-TFB	5349-TFB	—	—
	Duplex Receptacle Floor Box, 1 or 2 Duplex Receptacles	Brass	25249-TFB	25349-TFB	35249-TFB	35349-TFB
	Duplex Receptacle Floor Box, 1 Duplex Receptacle & 1 QuickPort Insert*	Brass	—	—	35249-TLB	35349-TLB
	Duplex Receptacle Floor Box, 1 or 2 Duplex Receptacles	Nickel	25249-TFN	25349-TFN	35249-TFN	35349-TFN
	Duplex Receptacle Floor Box, 1 Duplex Receptacle & 1 QuickPort Insert*	Nickel	—	—	35249-TLN	35349-TLN
Standard	Duplex Receptacle Floor Box, 1 Duplex Receptacle	Brass	25249-FBA	25349-FBA	—	—
	Duplex Receptacle Floor Box, 1 Duplex Receptacle	Nickel	25249-SBA	—	—	—
Caps	Single Receptacle Replacement Cap & Gasket	Brass	5249-CAP (for use with Leviton Catalog Numbers 5249-TFB and 5349-TFB)		—	—
	Duplex Receptacle Replacement Cap & Gasket	Brass	25249-CAP (for use with 25249-FBA, 25249-TFB, 25349-FBA, 25349-TFB, 35249-TFB, 35349-TFB, 35249-TLB, 35349-TLB)			

\*QuickPort snap-in modules sold separately

## Additional Receptacle Options for use with Floor Box - Sold Separately

Color	Hospital Grade Duplex Receptacles	
	15A	20A
Brown	8200F-SG*	8300F-SG*
Ivory	8200F-SGI*	8300F-SGI*
White	8200F-SGW*	8300F-SGW*
Gray	8200F-SGG*	8300F-SGG*
Lt. Almond	8200F-SGT*	8300F-SGT*
Red	8200F-SGR*	8300F-SGR*

\*Special Order Configuration

Color	Isolated Ground Duplex Receptacles	
	15A	20A
Orange	5262-FIG	5362-FIG
Red	5262-FGR	5362-FGR

Color	Duplex Receptacles for use with Floor Box	
	15A	20A
Red	5262-FR	5362-FR

## Specifications

Description	5249-TFB	5349-TFB	25249-TFB 35249-TFB 35249-TLB	25349-TFB 35349-TFB 35349-TLB	25249-TFN 35249-TFN 35249-TLN	25349-TFN 35349-TFN 35349-TLN	25249-FBA 25249-SBA	25349-FBA
<b>AC Horsepower Rating</b>								
At Rated Voltage	½ HP	1 HP	½ HP	1 HP	½ HP	1 HP	½ HP	1 HP
<b>Electrical Specifications</b>								
Amperage	15A	20A	15A	20A	15A	20A	15A	20A
Voltage	125V	125V	125V	125V	125V	125V	125V	125V
NEMA	5-15R	5-20R	5-15R	5-20R	5-15R	5-20R	5-15R	5-20R
Pole	2							
Wire	3							
<b>Environmental Specifications</b>								
Flammability	Rated V-2 per UL94							
Operating Temp.	-40° C to +75° C							
<b>Material Specifications</b>								
Receptacle Face (Ivory)	Polycarbonate		Polypropylene				Nylon	
Receptacle Body	Nylon		Polypropylene				Nylon	
Duplex QuickPort Insert (Ivory), -TL models only	—		ABS (V-0) with galvanized steel strap				—	
Shutter Mechanism (TR only)	Delrin® Acetal				—			
Receptacle Line Contacts	Brass, Triple-Wipe		Brass, Hot: Double-Wipe, Neutral: Triple-Wipe				Brass, Triple-Wipe	
Receptacle Mounting Screws	Steel 10-32							
Receptacle Grounding Screw	Steel 8-32							
Receptacle Strap	Zinc-Plated Steel							
Floorplate	Brass: 0.06"				Nickel-Plated Brass: 0.06"			
Cap	Brass				Nickel-Plated Brass			
<b>Mechanical Specifications</b>								
Terminal ID	Brass-Hot, Green-Ground, Silver-Neutral							
Terminal Accom.	14-10 AWG							
Termination	Back and Side Wiring							
<b>Standards &amp; Certifications</b>								
NEMA	WD-1 and WD-6							
ANSI	C-73							
Certification / Listing	cCSAus, NOM-ANCE							
Applicable Standards	UL 498, UL 514A, CSA C22.2 No. 42, CSA C22.2 No. 18.1-04							
<b>Warranty</b>								
Product Warranty	2-Year Limited							

Brass Finish



Nickel Finish



## Dimensions

### 1-Gang, Single Receptacle Floor Box

Front View

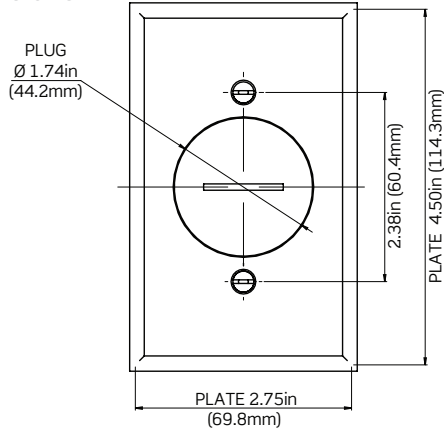

Top View

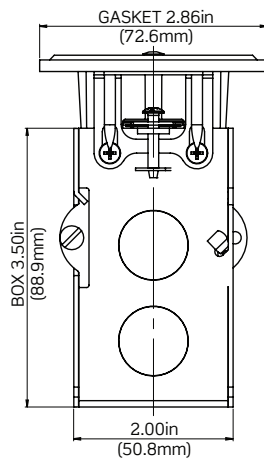

Side View

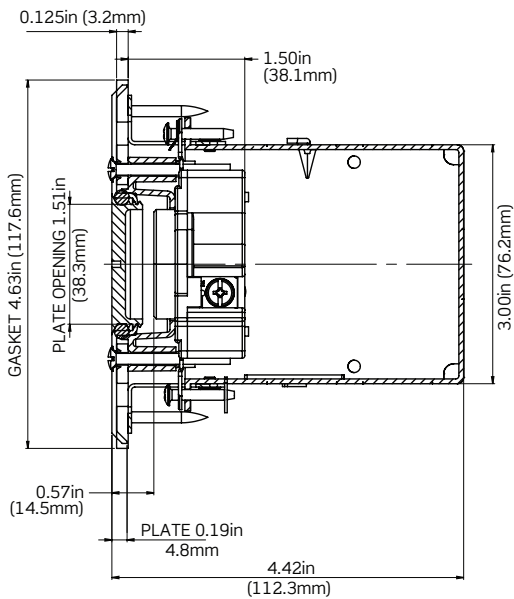

### 1-Gang, Duplex Receptacle Floor Box

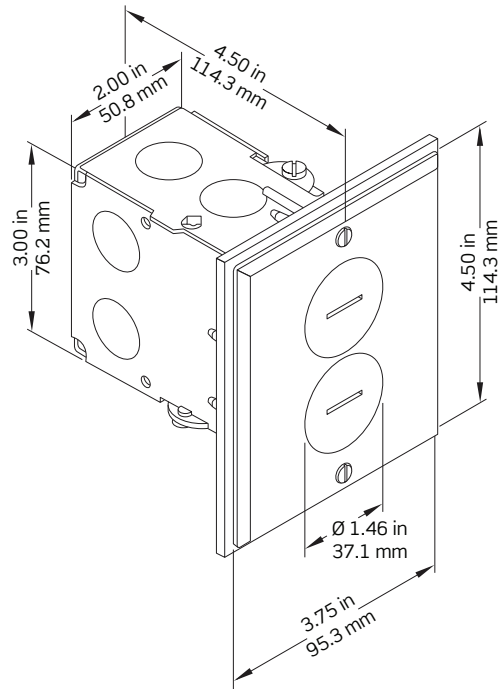

### 2-Gang, Duplex Receptacle Floor Box

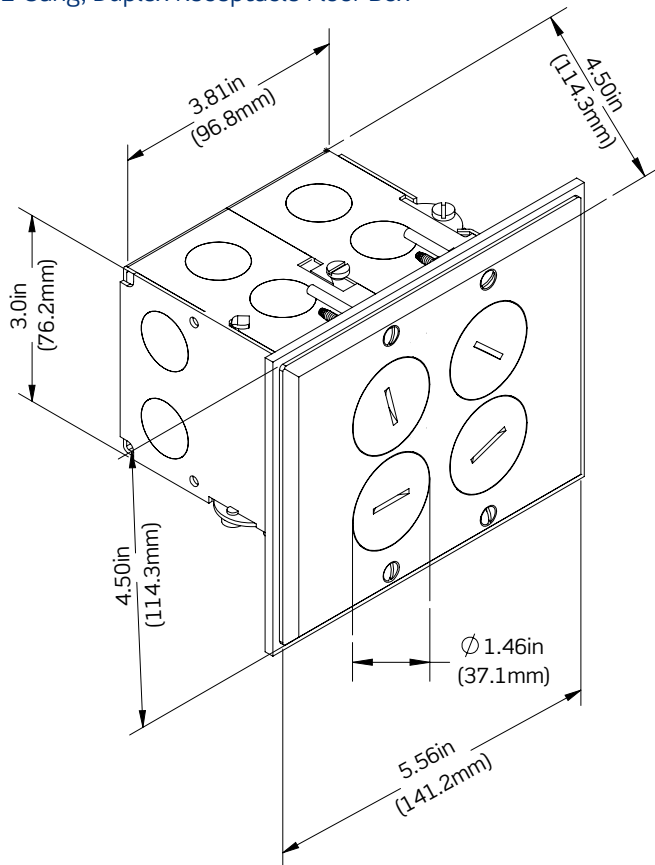

Visit our Website at:

[www.leviton.com/commercial](http://www.leviton.com/commercial)

email: [commercial@leviton.com](mailto:commercial@leviton.com)

Q-916D

Leviton Manufacturing Co., Inc.

201 N Service Rd, Melville, NY 11747

Telephone: 1-800-323-8920 • FAX: 1-800-832-9538

Tech Line: 1-800-824-3005 (M-F 8AM-10PM; Sat 9AM-7PM; Sun 9AM-5PM)

© 2022 Leviton Manufacturing Co., Inc. All rights reserved.

051322

