

Electric Vehicle Charging Station

Installation Manual

Cat. No. EV48S-DP

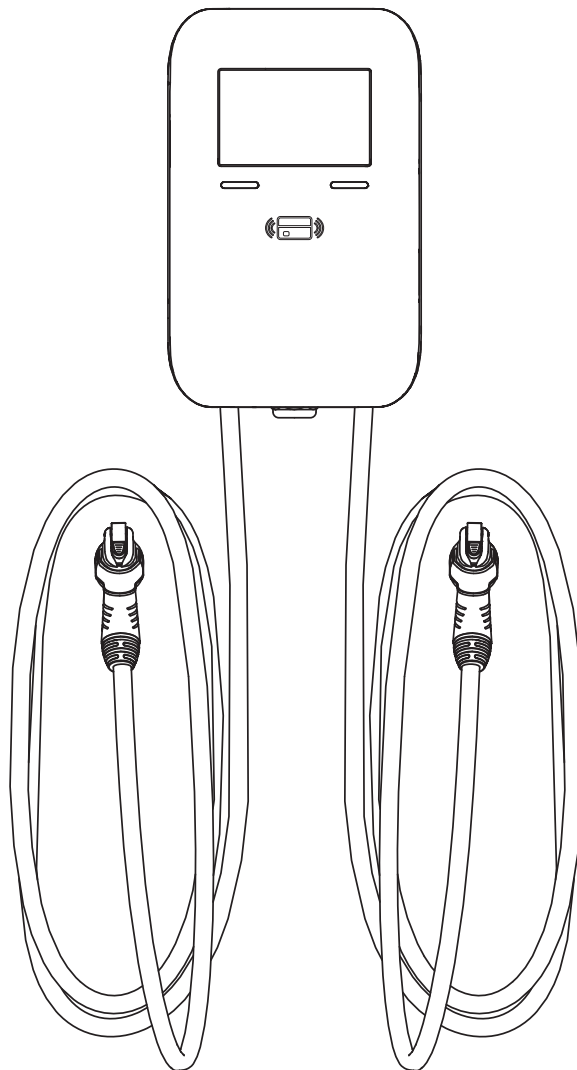

TABLE OF CONTENTS

1	Warnings and Cautions.....	4
2	Safety Standards and Specifications	5
3	Tools Needed	6
4	Basic Interface	8
5	Dimensions	9
6	Status Light Indicators	10
7	Installation	11
	7.1 Wall Mount Installation.....	11
	7.2 Electrical Connection	13
8	Error and Warning Messages	16
9	Maintenance	17
10	Standard Statements and Warranty	18

1 WARNINGS AND CAUTIONS

WARNINGS:

- **TO AVOID FIRE, SHOCK, OR DEATH; TURN OFF POWER AT CIRCUIT BREAKER OR FUSE AND TEST THAT POWER IS OFF BEFORE WIRING, REPLACING OR SERVICING THE PRODUCT!**
- **HAZARD OF ELECTROCUTION, SHOCK, EXPLOSION, OR ARC FLASH.** This device has arcing or sparking parts that should not be exposed to flammable vapors.
- **TO AVOID FIRE, SHOCK, DEATH, OR DAMAGE TO THE CHARGER,** carefully read the charging instructions in your vehicle's manual before you use the charger.
- **RISK OF ELECTRIC SHOCK.** Do not remove cover or attempt to open the enclosure of the device.
- This device should be installed, adjusted, and serviced by qualified electrical personnel familiar with the construction and operation of this type of charger and the dangers involved.
- Do not forcefully pull the charging cable, damage it with sharp objects, put fingers, or insert foreign objects into any part of the charging connector.
- Do not use the charger when you are in the vehicle, or the charger is exposed to severe rain, snow, or other severe weather.
- Connect only to a circuit providing branch circuit overcurrent protection in accordance with the National Electrical Code, ANSI/NFPA 70 (United States), the Canadian Electrical Code, Part I, C22.1. Canada), or NOM-001-SEDE (Mexico).

CAUTIONS:

- No user serviceable parts inside.
- The device is designed only for vehicles that are compatible with the SAE J1772 Level 2 charging standard.
- Do not use the charger if it is defective, appears cracked, frayed, broken, or damaged.
- When transporting the charger, handle with care and do not drag or step on the device.
- Do not touch the charging connector terminal with sharp metallic objects to prevent damage.
- Incorrect installation and testing of the charger could potentially damage either the vehicle's battery or the device. Any resulting damage is excluded from the warranty for the device.
- Ensure that the charging cable is positioned properly during charging so it does not get stepped on, tripped over, or subjected to damage or stress.
- Use appropriate protection when connecting to the main power distribution cable.
- Type B, C or D breaker with the rating current for table must be installed in the upstream AC distribution box.
- Disconnect switch for each unground conductor of AC input (not included) in accordance with the National Electrical Code ANSI/NFPA 70.

2 SAFETY STANDARDS AND SPECIFICATIONS

Design Safety Standards

UL2594: Electric Vehicle Supply Equipment
UL 2231-1: Personnel Protection Systems for Electric Vehicle (EV) Supply Circuits: General Requirements
UL 2231-2: Personnel Protection Systems for Electric Vehicle (EV) Supply Circuits: Particular Requirements for Protection Devices for Use in Charging Systems
UL 2251: Plugs, Receptacles and Couplers for Electric Vehicles
UL 62: Flexible Cords and Cables
UL 991: Tests for Safety-Related Controls Employing Solid-State Devices
UL 1998: Software in Programmable Components
NFPA 70 Article 625: National Electrical Code, Electric Vehicle Charging System
UL840 (Clearance and Creepage)
Energy Star Certified
FCC Part 15 Certified
California Type Evaluation Program (CTEP) Certified
ISO 15118-2,3 Compliant

Specifications

Model Name	EV48S-DP
Rated Input Voltage	208-240 VAC / Single Phase
Rated Output Current	48A x 2
AC Power Frequency	50/60 Hz
Input Protection	UVP, OVP, RCD, SPD, Ground Fault Protection
Output Protection	OCP, OTP, Control Pilot Fault Protection
Output Interface	SAE J1772 AC Charging Connector
Storage Temperature	-40°F (-40°C) to +185°F (85°C)
Operation Temperature	-22°F (-30°C) to +131°F (50°C)
Relative Operation Humidity	95% RH Maximum
Relative Storage Humidity	95% RH Maximum
Circuit Breaker/Fuse Rating	120A for Single Circuit supplying both ports or 60 A x 2 for 2 Circuits individually supplying power to each port
Connectivity	Bluetooth 5.2, Wi-Fi 6 (2.4 GHz/5 GHz), Ethernet, Cellular 4G
Communication Protocols	OCPP 2.0.1/OCPP 1.6JS Self-Adaptation, ISO15118-2/3
Cable Length	25 ft
Protection Level	IK08 and IP54; NEMA Type 3
Installation Type	Wall mount or pedestal mount
Altitude	≤ 2,000 m
Weight	37 lbs (16.8 kgs.)
Dimensions	19.2 in. x 12.2 in. x 4.8 in. (488 mm x 310 mm x 122 mm)
Status Indication	Red, Green, Blue, Yellow LED
User Interface	7 in. Touch Screen; English (Default), Spanish, French
User Authentication	Mobile App, RFID Card, None
Warranty	36 months

3 TOOLS NEEDED

Tools Required:

1. Level
2. Drill
3. Rubber mallet
4. Philips screwdriver
5. Wire stripper
6. Voltmeter or digital multi-meter
7. 10 mm combination wrench
8. Flat blade screwdriver

1



2

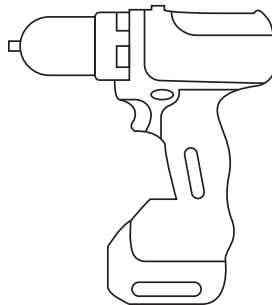

3

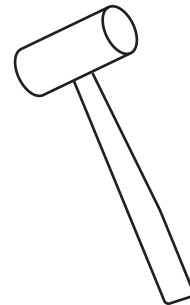

4

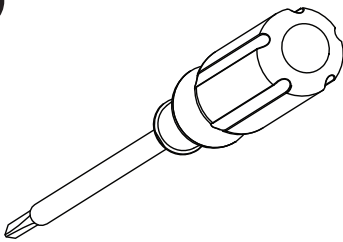

5

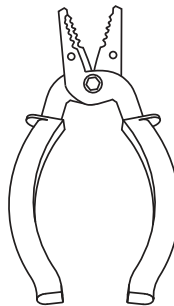

6

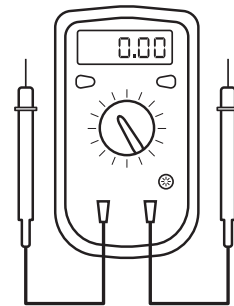

7

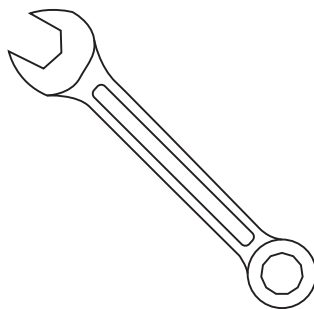

8

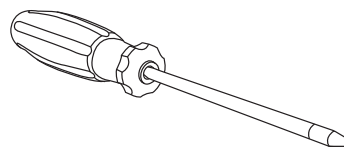

3 TOOLS NEEDED

Contents Include:

#	Product Name	Quantity
1	AC Charger (With Charging Cable)	1
2	User Manual	1
3	Mounting Bracket	1
4	Mounting Template	1
5	M6 Expansion Screws	4
6	T20 Torx Key	1
7	Shorting Terminal Set	1
8	Ring Terminal	6
9	Cable Clamp	1
10	AD 21.2 mm Conduit Fitting	1
11	AD 42.5 mm Conduit Fitting	1
12	Cable Gland	1
13	Self-Tapping Screws 3.5*16	2

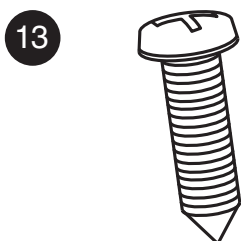
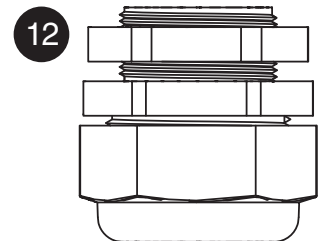
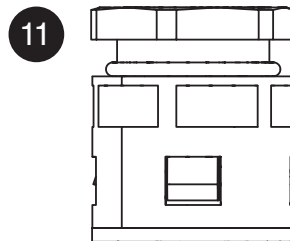
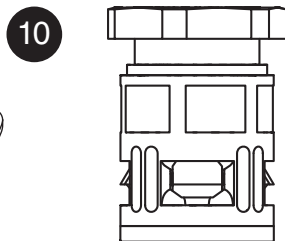
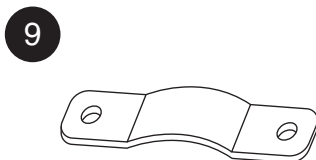
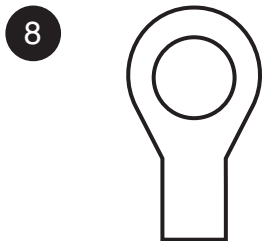
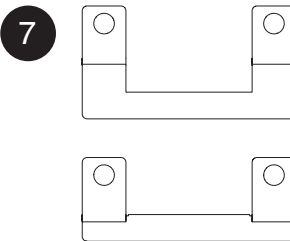
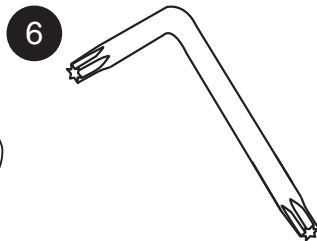
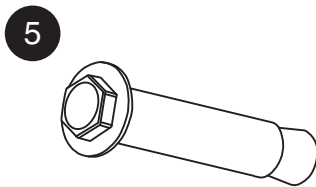
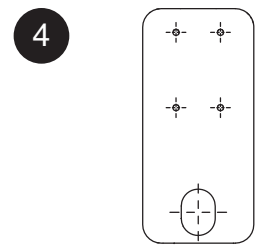
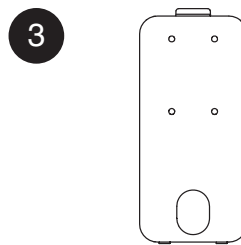
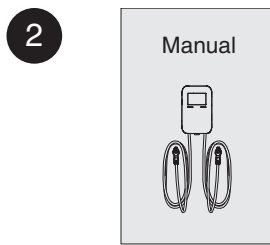
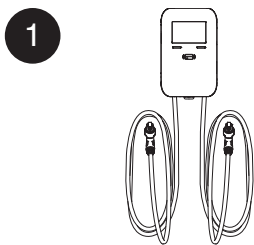

4 BASIC INTERFACE

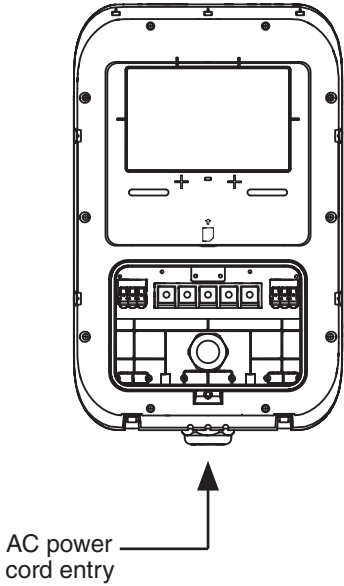
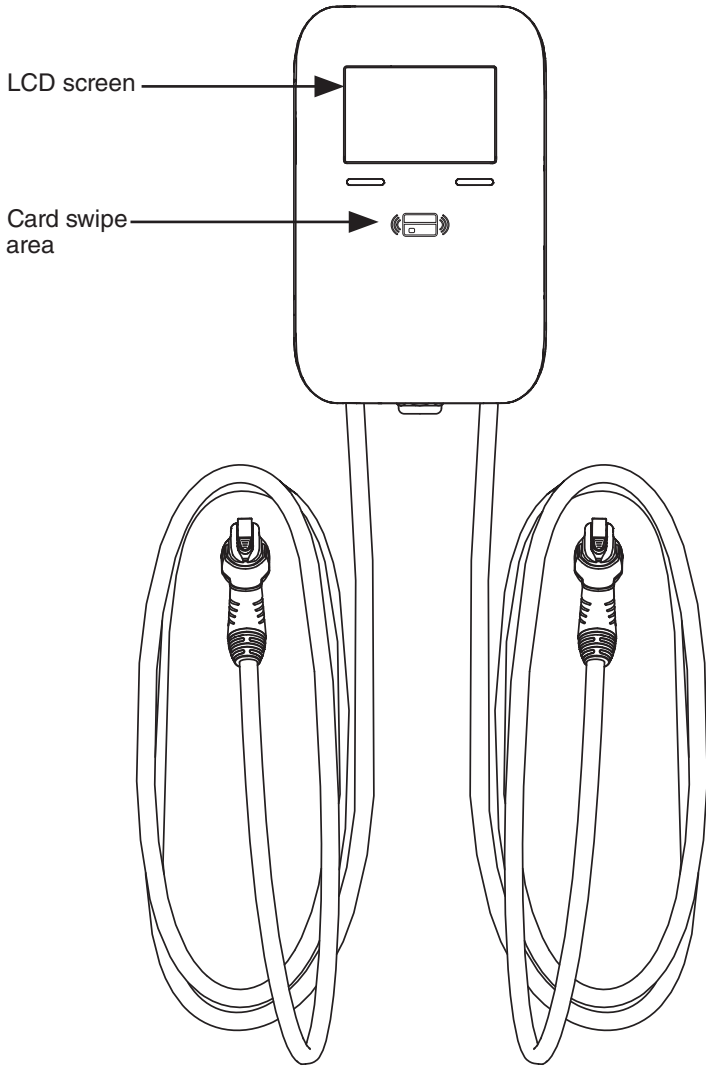



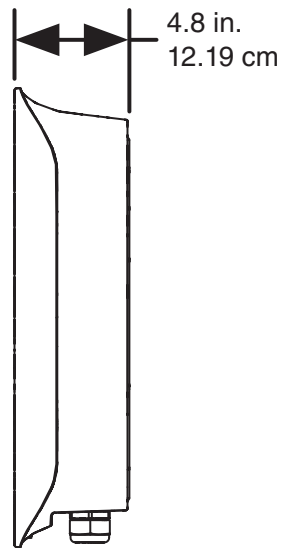
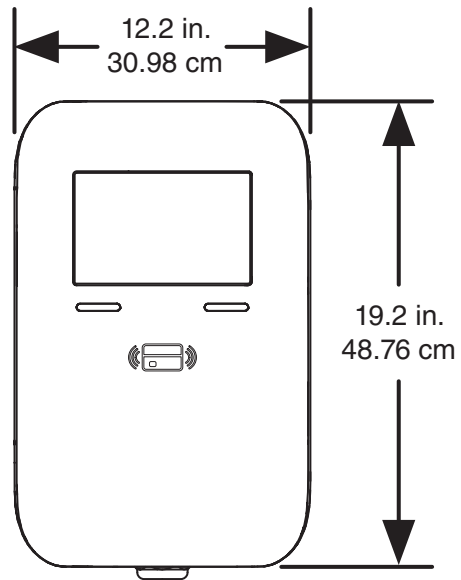



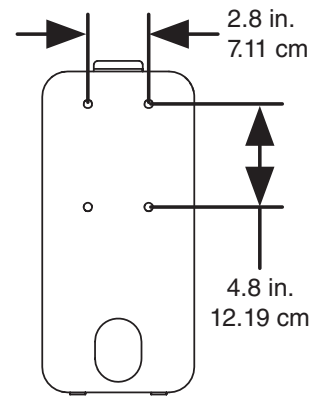



5 DIMENSIONS

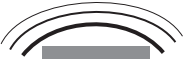

Mounting Bracket



6 Status Light Indicators

Charger Indication Light Status	
 Blue, Green, Red Light	Power On - Blue, Green, and Red run clockwise
 Blue Light	Standby - Solid Blue
 Green Light	Charger Connected to Vehicle - Solid Green
 Green Light Blinking	Waiting for Authentication (Swipe Card) - Green Blinking
 Green Light Breathing	Charging In Progress - Green Breathing
 Green Light	Finished/Stopped Charging - Solid Green
 Yellow Light	Reservation Charging - Solid Yellow
 Yellow Light Blinking	Device Unavailable - Yellow Blinking
 Yellow Light Breathing	OTA - Yellow Breathing
 Red Light	Fault - Red light

7 INSTALLATION

7.1 Wall Mount Installation

These instructions and included hardware are for mounting to a concrete wall. For other surfaces, obtain the appropriate mounting hardware.

1. Attach the Mounting Template

- Position the template on the wall where the charger will be installed.
- The top of the template should be approximately 48 inches from the ground.
- For ADA compliance, check local building codes for specific mounting height requirements.

2. Mark the locations of the four screw holes and drill holes with a diameter of 0.33 in. (8.5 mm) and a depth of 2.05 in. (52 mm).

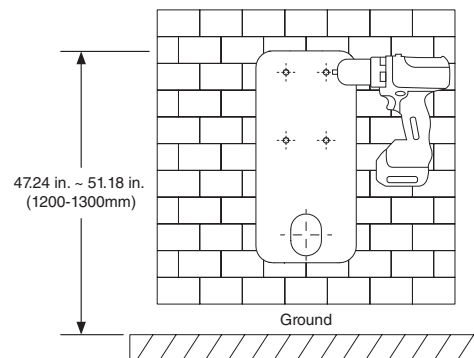

3. Use the provided Torx key to remove the two screws attaching the mounting bracket to the charger.

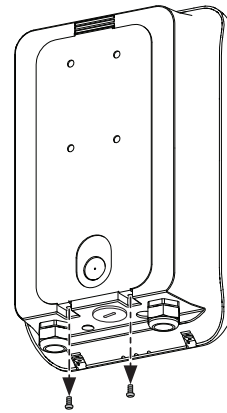

4. Lift the mounting bracket away from the charger to remove the mounting bracket.

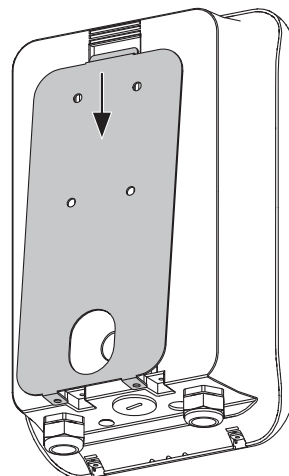

7 INSTALLATION

5. Align the bracket's screw holes with the holes in the wall. Insert the four expansion screws and use a rubber mallet to tap them in fully.

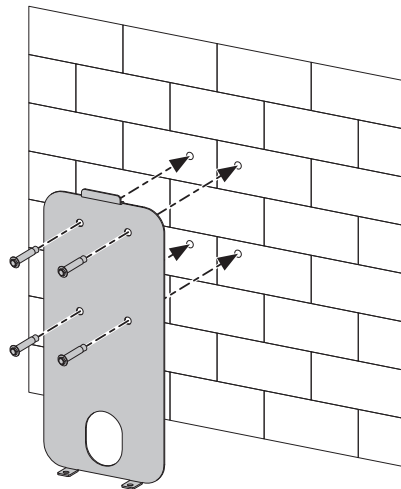

6. Tighten the screws with a combination wrench and attach the bracket to the wall.

7. Align the notch in the rear of the charger with the wall-mount bracket.

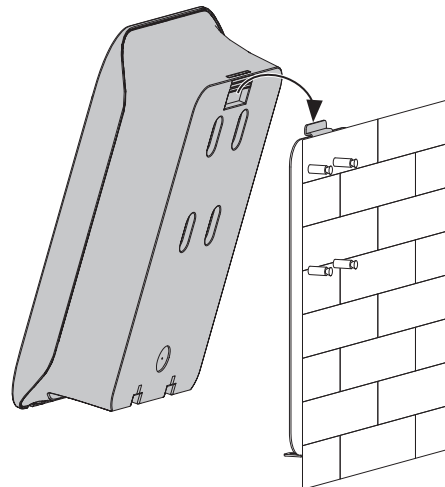

8. Slide the charger into place and align the screw holes at the bottom. Secure the charger using the previous removed screws.

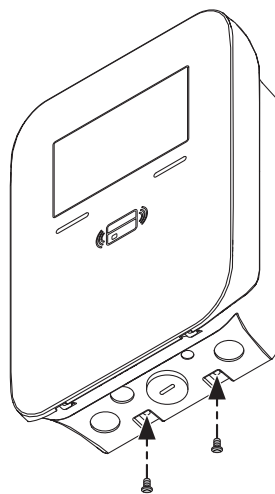

7 INSTALLATION

7.2 Electrical Connection

1. Remove the charger cover. Use the Torx key to unscrew the two screws securing the cover to the bottom of the enclosure.
2. Gently grasp the sides of the cover and pull it away to disengage the latches, then remove it.

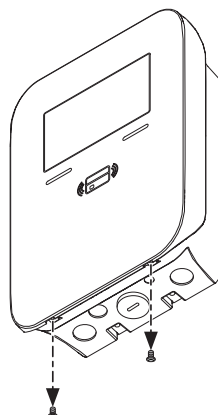

3. Remove the Wiring Access Panel. Use a flat-blade screwdriver to unlock the latches and remove the panel.

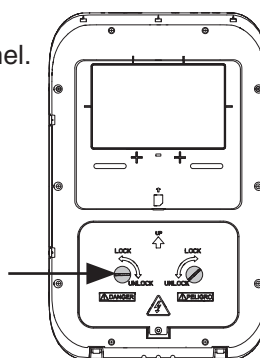

4. Remove the waterproof plug from the cable inlet.

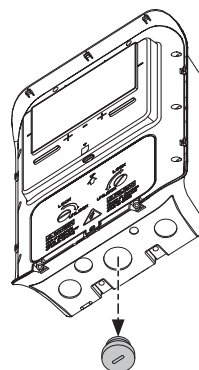

5. Install the appropriate cable fitting:
 - For a single jacket cable (OD range 0.86 in. to 1.26 in.), install the included cable gland.
 - For multiple cables, install the included AD 42.5 mm conduit fitting.
Note: plastic corrugated conduit must be obtained separately.

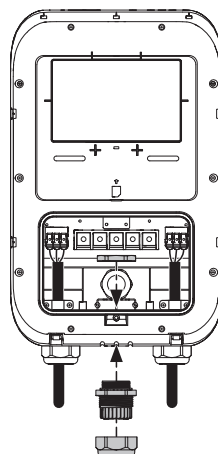

7 INSTALLATION

Route and Connect Cables for Single Circuit Supplying Both Ports

1. Use shorting terminals to connect the L1 to L1 (1) and L2 to L2 (1).

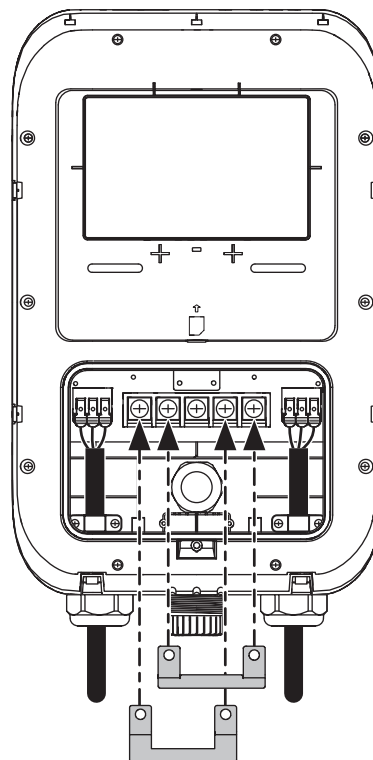

2. Connect phase conductors to terminals marked L1 and L2, and the ground conductor to the terminal marked GND.

3. If using the cable gland, secure the cable with the supplied cable clamp and self-tapping screws. Continue to Step 4 on next page.

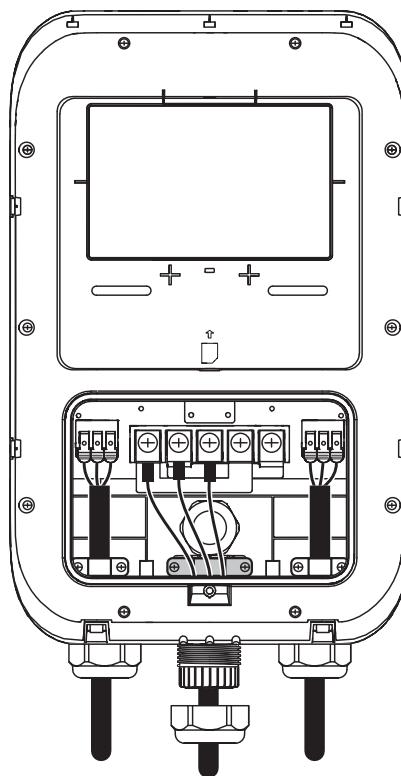

7 INSTALLATION

Route and Connect Cables for Individual Circuits Supplying Each Port

1. Connect phase conductors from circuit 1 to terminals marked L1 and L2.
2. Connect phase conductors from circuit 2 to terminals marked L1 (1) and L2 (2).
3. Connect ground conductors from both circuits to the terminal marked GND.

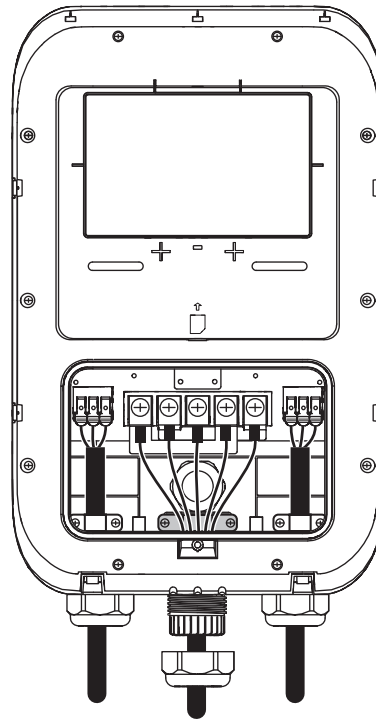

4. Reinstall the wiring access panel. Ensure that the cover is seated flush, and the fasteners are locked.
5. Reinstall the charger cover. Ensure it snaps into place around the entire perimeter. Reinstall the fastening screws.

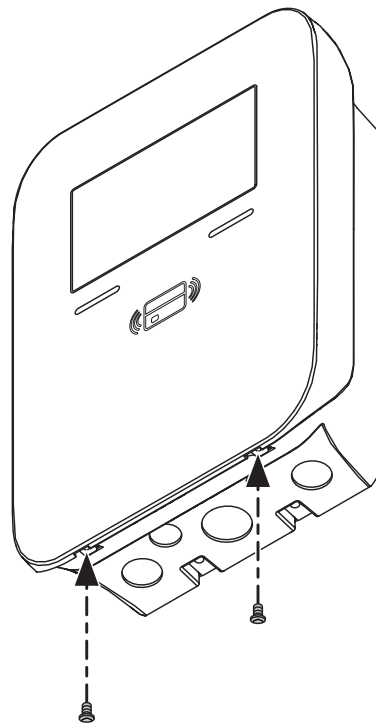

8 ERRORS AND WARNING MESSAGES

No.	Fault Status	Red Light	Remark
1	Meter Fault	1 flash followed by 3 second pause	Auto Recover
2	CP Fault	2 flashes followed by 3 second pause	Unplug the Connector to Recover
3	UVP	3 flashes followed by 3 second pause	Auto Recover
4	OVP	4 flashes followed by 3 second pause	Auto Recover
5	OTP	5 flashes followed by 3 second pause	Auto Recover
6	OCP	6 flashes followed by 3 second pause	Unplug the Connector to Recover
7	Ground Fault	7 flashes followed by 3 second pause	Unplug the Connector to Recover
8	Relay Fault	8 flashes followed by 3 second pause	Unplug the Connector to Recover
9	RCD Abnormal	9 flashes followed by 3 second pause	Unplug the Connector to Recover
10	RCD Self-Test Fault	10 flashes followed by 3 second pause	Reboot to Recover
11	Relay Self-Test Fault	11 flashes followed by 3 second pause	Reboot to Recover
12	Sensor Fault	12 flashes followed by 3 second pause	Check Sensor or Contact After-Sales
13	Cable Fault	13 flashes followed by 3 second pause	Check Cable or Contact After-Sales

9 MAINTENANCE

WARNING:

Avoid moisture or water in the charger. If there is water or moisture, immediately power OFF the charger, and notify professional personnel to perform maintenance before its next use.

CAUTIONS:

- Keep the charger clean and in an area with low humidity. Do not install it in an environment that is near the sea, or with high-oil, high-humidity, or high-dust.
- If there is any damage or dirt on the vehicle connector, charging cable, or vehicle connector holder, please contact the maintenance personnel immediately.
- Please use the charger properly. Do not hit or press hard on the case or place heavy objects on the charger. If the case is damaged, please contact a professional technician.
- Avoid placing the charger near hot objects, in high-temperature locations, and away from dangerous substances, such as flammable gases and corrosive materials.

10 STANDARD STATEMENTS AND WARRANTY

FCC STATEMENT:

This device complies with Part 15 of the FCC Rules and ISED License-exempt RSS standard(s). Operation is subject to the following two conditions: (1) This device may not cause harmful interference, and (2) This device must accept any interference received, including interference that may cause undesired operation. Changes or modifications not expressly approved by Leviton could void the user's authority to operate the equipment.

These limits are designed to provide reasonable protection against harmful interference in a commercial installation. This equipment generates, uses and can radiate radio frequency energy and, if not installed and used in accordance with the instructions, may cause harmful interference to radio communications. However, there is no guarantee that interference will not occur in a particular installation. If this equipment does cause harmful interference to radio or television reception, which can be determined by turning the equipment off and on, the user is encouraged to try to correct the interference by one or more of the following measures:

- Reorient or relocate the receiving antenna.
- Increase the separation between the equipment and receiver.
- Connect the equipment into an outlet on a circuit different from that to which the receiver is connected.
- Consult the dealer or an experienced radio/TV technician for help.

This Class A digital apparatus complies with Canadian CAN ICES-3(A)/NMB-3(A).

FCC SUPPLIER'S DECLARATION OF CONFORMITY:

This device complies with Part 15 of the FCC Rules. Operation is subject to the following two conditions: (1) This device may not cause harmful interference, and (2) this device must accept any interference received, including interference that may cause undesired operation.

TRADEMARK DISCLAIMER:

Leviton and the Leviton logo are trademarks of Leviton Manufacturing Co., Inc. Use herein of third party trademarks, service marks, trade names, brand names and/or product names are for informational purposes only, are/may be the trademarks of their respective owners; such use is not meant to imply affiliation, sponsorship, or endorsement.

Leviton Manufacturing Co., Inc.
201 North Service Road, Melville, NY 11747

Visit Leviton's website at www.leviton.com.

© 2025 Leviton Manufacturing Co., Inc. All rights reserved.

Specifications and price subject to change at any time without notice.

FOR CANADA ONLY

For warranty information and/or product returns, residents of Canada should contact Leviton in writing at **Leviton Manufacturing of Canada ULC** to the attention of the **Quality Assurance Department, 165 Hymus Blvd, Pointe-Claire (Quebec), Canada H9R 1E9** or by telephone at **1 800 405-5320**.

LIMITED 3 YEAR WARRANTY

For Leviton's limited 3 year product warranty, go to www.leviton.com. For a printed copy of the warranty, call 1-800-323-8920.

For Technical Assistance Call: 1-800-824-3005 (USA Only) or 1-800-405-5320 (Canada Only) www.leviton.com

For Software and Setup Technical Assistance Call: 1-833-692-6787

