

100A Marine Grade Watertight Pin and Sleeve Receptacle

Cat. Nos. M5100R7WLEV, M5100R9WLEV, and M4100R12WLEV



WARNINGS:

- **TO AVOID FIRE SHOCK, OR DEATH, TURN OFF POWER AT CIRCUIT BREAKER OR FUSE, TEST THAT POWER IS OFF BEFORE SERVICING OR WIRING!**
- These devices conform to IEC standards 60309-1 and 60309-2. The construction is such that each device cannot be mated with another IEC device of different specifications (i.e., voltage, amperage or system rating). For safety purposes, do not use a non-IEC device with these pin and sleeve devices. The specifications for non-IEC devices are established by the individual manufacturers, and may not meet IEC standards. **IMPROPER MATING OF DEVICES MAY CAUSE AN ELECTRICAL HAZARD WHICH MAY CAUSE FIRE, SHOCK OR DEATH.**
- Examine devices periodically for any foreign matter that may contaminate the contacts or the insulation material separating the contacts. Contamination decreases the device's insulation properties. This increases the potential for arcing and possibly decreases the product's life and may cause fire and/or shock hazard. The frequency of inspection depends upon the degree of contamination.
- If you are unsure about any part of these instructions, consult an electrician.
- To be installed and/or used in accordance with electrical codes and regulations (Including NEC/CEC, as applicable).

CAUTIONS:

- Use this device only with copper wire.
- **DO NOT** tin conductors.

PK-A3497-10-02-0A

INSTALLATION INSTRUCTIONS

ENGLISH

Cleaning Procedures

WARNING: RISK OF ELECTRIC SHOCK. TURN OFF POWER AT CIRCUIT BREAKER OR FUSE. DO NOT clean this product while undergoing electrical maintenance or service.

CAUTIONS:

- Use only chemicals and cleaning solutions that are safe for use with plastics and rubber gaskets.
- **DO NOT** direct or concentrate high pressure water or cleaning solution on the enclosure gasket seams, switch handle area or exterior labels.

NOTES:

- Follow general cleaning procedures established by your facility.
- Ensure that all contact surfaces are kept clean and periodically sprayed with a corrosive-resistant electrical contact cleaner or lubricant.

Installation

WARNING: TO AVOID FIRE, SHOCK OR DEATH: TURN OFF POWER SUPPLYING THIS EQUIPMENT AND CONFIRM POWER IS OFF, before installing, removing or servicing this equipment.

1. Cut and strip cable jacket and conductors (Table 1 and Stripping and Wiring Diagram).

WARNING: TO AVOID FIRE, SHOCK OR DEATH, connections must be made in the same sequence as existing device connections. Connect wires (Table 2 and Stripping and Wiring Diagram). Tighten terminal screws (Table 4).

NOTE: Separate grounding wire has been pre-installed. Connect ground wire first.

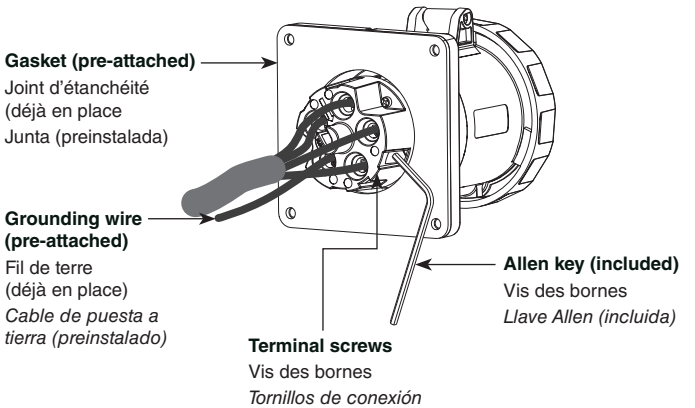

2. Mount (Table 5) and tighten mounting screws.

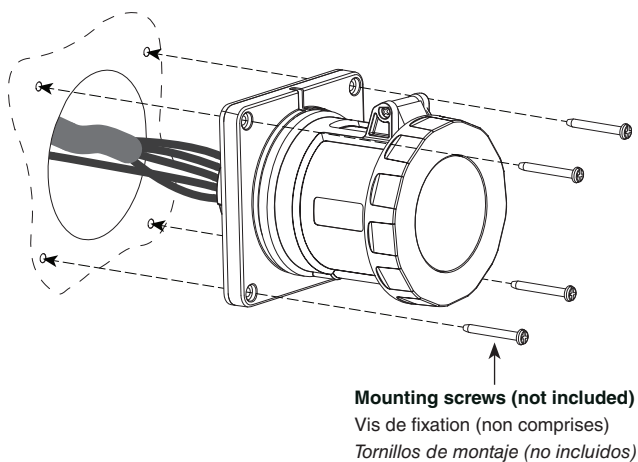

1 Cable Stripping Guide

Device	No. Wires	No. Conductors	Cable Jacket (A)	Conductor (B)
100A	All	All	3.5 in. 89 mm	1 in. 25 mm

Stripping and Wiring Diagram

(See Table 1)

2 Terminal Identification Chart

⏚ and green color	Equipment ground conductor
N and white color	Grounded circuit conductors (neutral).
L1, L2, L3	Ungrounded circuit conductors (line, hot).
Pilot	Control circuit conductor.

3 Wire Sizes

Device	From			To			Grip Range Minimum/ Maximum Wire Diameter
	AWG	COND	TYPE	AWG	COND	TYPE	
100A	#6	3	W	#1	3	W	0.725/1.890 in. 18/48 mm
		4			4		
		5			5		

4 Screw Tightening Guide in-lbs (N-m)

Device	Terminal	Pilot Terminal Screws	Assembly Screws
100A	50 (5.65)	20 (2.26)	N/A

5 Drilling Plan Receptacles and Inlets

No. Wires; Device	A		B		C (min)		D
	Inches	mm	Inches	mm	Inches	mm	
100A; All	3.47	88	4.88	124	7.87	200	#10

FOR CANADA ONLY

For warranty information and/or product returns, residents of Canada should contact Leviton in writing at Leviton Manufacturing of Canada ULC to the attention of the Quality Assurance Department, 165 Hymus Blvd, Pointe-Claire (Quebec), Canada H9R 1E9 or by telephone at 1-800-405-5320.

LIMITED 1 YEAR WARRANTY AND EXCLUSIONS

Leviton warrants to the original consumer purchaser and not for the benefit of anyone else that this product at the time of its sale by Leviton is free of defects in materials and workmanship under normal and proper use for one year from the purchase date. Leviton's only obligation is to correct such defects by repair or replacement, at its option. **For details visit www.leviton.com or call 1-800-824-3005.** This warranty excludes and there is disclaimed liability for labor for removal of this product or reinstallation. This warranty is void if this product is installed improperly or in an improper environment, overloaded, misused, opened, abused, or altered in any manner, or is not used under normal operating conditions or not in accordance with any labels or instructions. **There are no other or implied warranties of any kind, including merchantability and fitness for a particular purpose,** but if any implied warranty is required by the applicable jurisdiction, the duration of any such implied warranty, including merchantability and fitness for a particular purpose, is limited to one year. **Leviton is not liable for incidental, indirect, special, or consequential damages, including without limitation, damage to, or loss of use of, any equipment, lost sales or profits or delay or failure to perform this warranty obligation.** The remedies provided herein are the exclusive remedies under this warranty, whether based on contract, tort or otherwise.

For Technical Assistance Call: 1-800-824-3005 (USA Only) or 1-800-405-5320 (Canada Only) www.leviton.com

