

4

3

2

1

CATALOG # 16R30

16 SERIES SINGLE POLE CAM TYPE FEMALE PANEL CONNECTOR, 45-DEGREE, TAPER NOSE, THREADED STUD, 600 VOLTS RATED UP TO 400 AMPERES CONTINUOUS CABLE RANGE - #2 - 4/0

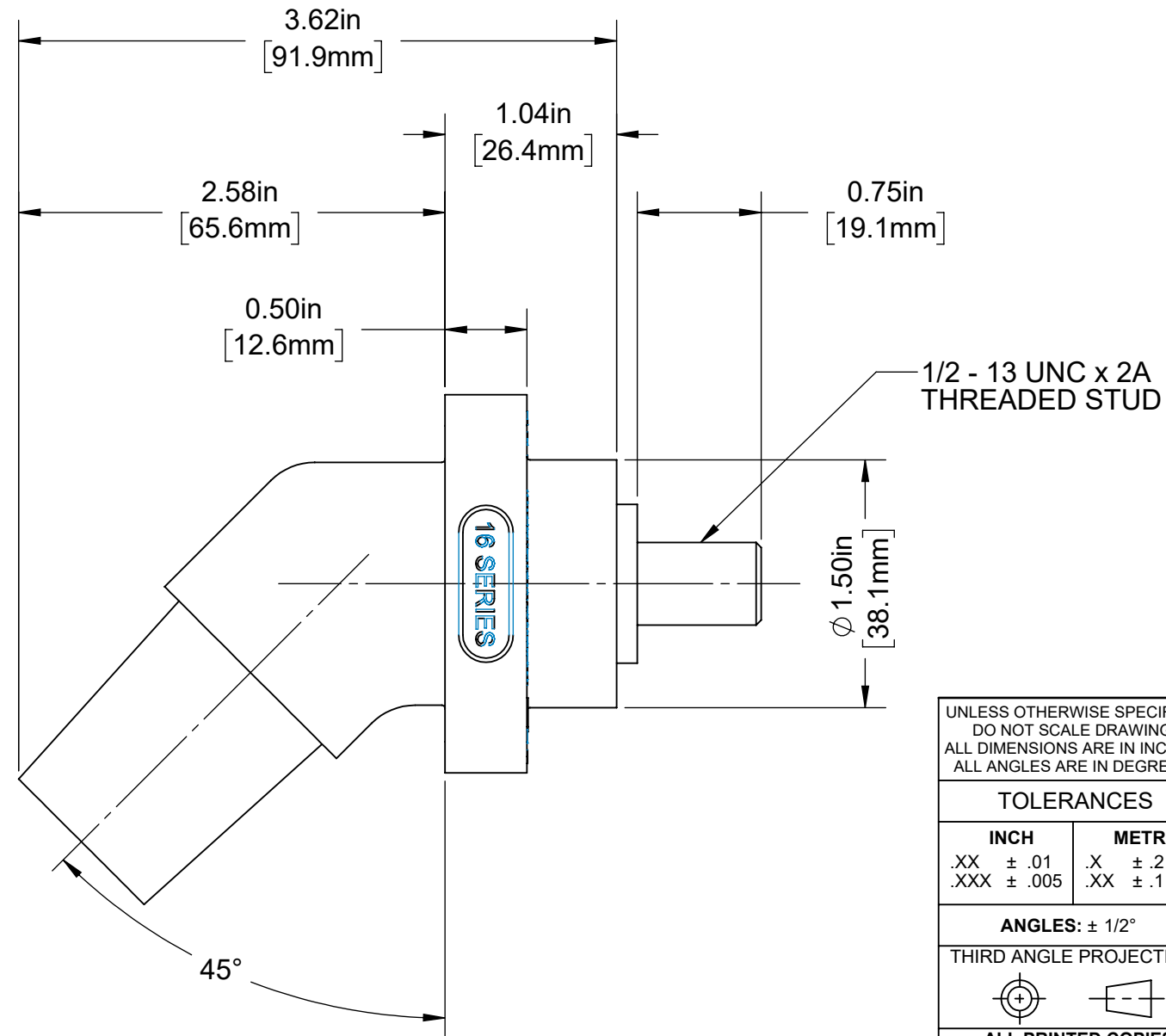
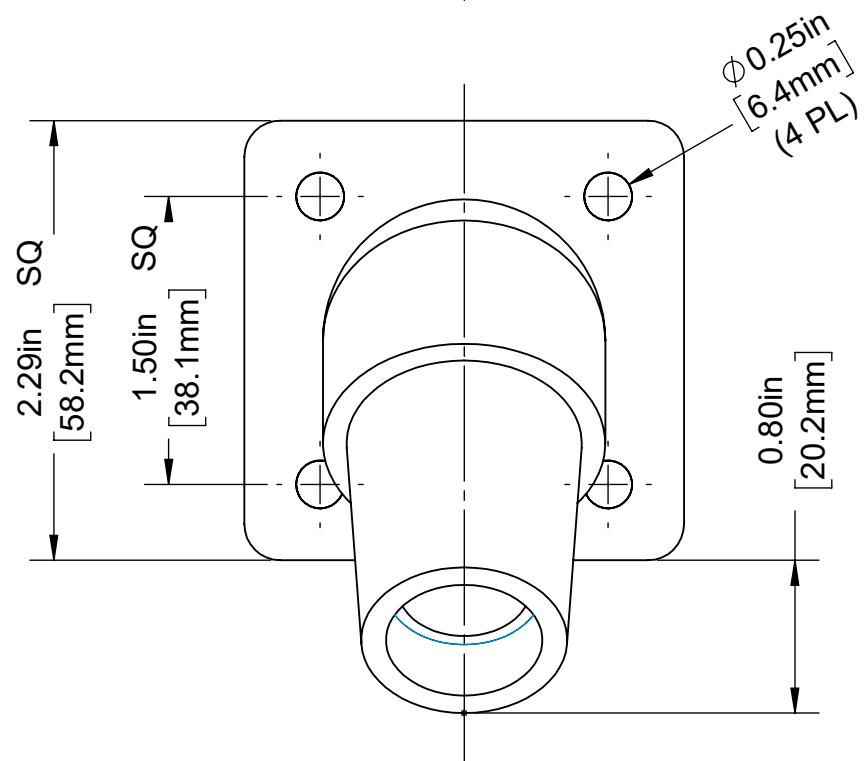
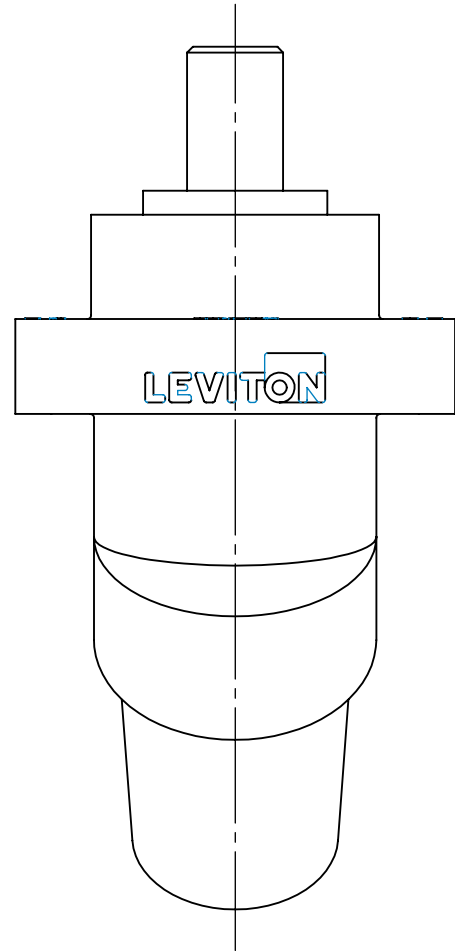

UNLESS OTHERWISE SPECIFIED:
DO NOT SCALE DRAWING.
ALL DIMENSIONS ARE IN INCHES.
ALL ANGLES ARE IN DEGREES.

TOLERANCES	
INCH	METRIC
.XX ± .01	.X ± .2 mm
.XXX ± .005	.XX ± .1 mm

ANGLES: ± 1/2°

THIRD ANGLE PROJECTION

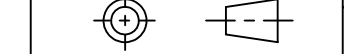

ALL PRINTED COPIES ARE UNCONTROLLED



TITLE:
**16R30 16 SERIES 45 DEGREE
PANEL MOUNT - STUD END**

DWG NO.
CATSTD-16R30-0XX-D01

SIZE B	SCALE:1:1	SHEET 1 OF 1	REV 1
------------------	-----------	--------------	-----------------

Copyright 2019. Unpublished. All Rights Reserved.

4

3

2

1