

4

3

2

1

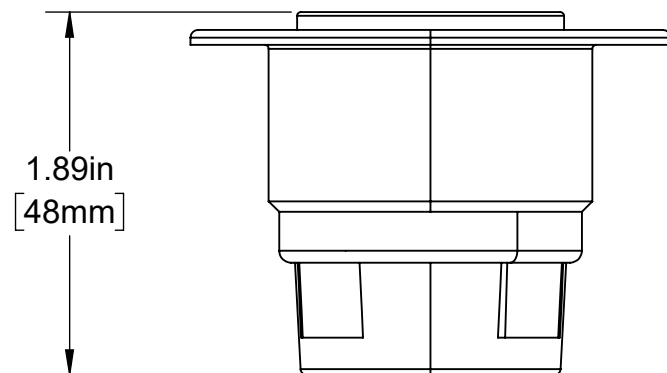
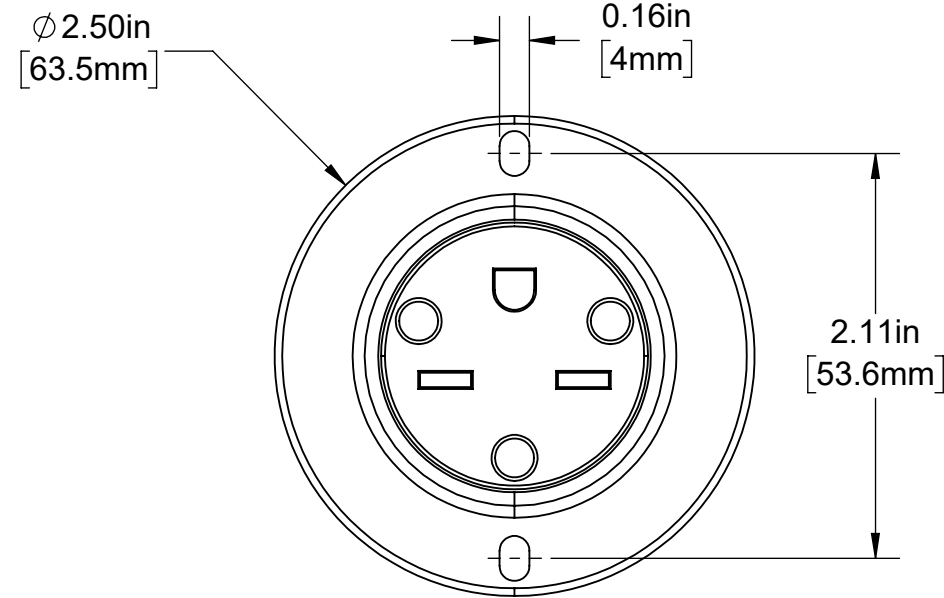

NOTES:

1. DIMENSIONS SHOWN ACROSS A CENTERLINE ARE SYMMETRICAL ABOUT THE CENTERLINE WITHIN SPECIFIED TOLERANCE.
2. CRITICAL CHARACTERISTICS ARE IDENTIFIED BY A RACEWAY (X.XXX) AROUND THE CHARACTERISTIC.
3. COMPONENT/PART/MATERIAL/FINISH SHALL VERIFIABLY COMPLY WITH THE MOST CURRENT DIRECTIVE ON THE RESTRICTION OF THE USE OF CERTAIN HAZARDOUS SUBSTANCES IN ELECTRICAL AND ELECTRONIC EQUIPMENT (RoHS).

UNLESS OTHERWISE SPECIFIED: DO NOT SCALE DRAWING. ALL DIMENSIONS ARE IN INCHES. ALL ANGLES ARE IN DEGREES.		LEVITON®		
TOLERANCES		TITLE: NEMA 6-15R FLANGED OUTLET RECEPTACLE		
INCH	METRIC			
.XX ± .01 .XXX ± .005	.X ± .2 mm .XX ± .1 mm			
ANGLES: ± 1/2°		DWG NO. CATSTD-15679-00C-D01		
THIRD ANGLE PROJECTION 		SIZE B	SCALE:1:1	SHEET 1 OF 1
ALL PRINTED COPIES ARE UNCONTROLLED		Copyright 2020. Unpublished. All Rights Reserved.		REV 1

4

3

2

1